

RADIO ASTRONOMY

**Journal of the Society of Amateur Radio
Astronomers**

March - April 2026



Doppler Tracking of Orion at DSES for the Artemis II Mission



Dr. Richard A. Russel

SARA President and Editor

Bogdan Vacaliuc

Contributing Editor

Radio Astronomy is published bimonthly as the official journal of the Society of Amateur Radio Astronomers. Duplication of uncopyrighted material for educational purposes is permitted but credit shall be given to SARA and to the specific author. Copyrighted materials may not be copied without written permission from the copyright owner.

Radio Astronomy is available for download only by SARA members from the SARA web site and may not be posted anywhere else.

It is the mission of the Society of Amateur Radio Astronomers (SARA) to: Facilitate the flow of information pertinent to the field of Radio Astronomy among our members; Promote members to mentor newcomers to our hobby and share the excitement of radio astronomy with other interested persons and organizations; Promote individual and multi station observing programs; Encourage programs that enhance the technical abilities of our members to monitor cosmic radio signals, as well as to share and analyze such signals; Encourage educational programs within SARA and educational outreach initiatives. Founded in 1981, the Society of Amateur Radio Astronomers, Inc. is a membership supported, non-profit [501(c) (3)], educational and scientific corporation.

Copyright © 2026 by the Society of Amateur Radio Astronomers, Inc. All rights reserved.

Cover Photo:

Richard Hambly and DSES Team

Contents

President's Page.....	2
Editor's Notes.....	3
SARA NOTES.....	4
2026 SARA Officers and Board Members Nominations.....	6
Where Art and Science Meet.....	12
Halfway to the Moon - The Bard of Lichfield.....	12
SuperSID.....	14
Announcing Radio JOVE 2.1.....	18
Featured Articles.....	25
Doppler Tracking of Orion at DSES for the Artemis-II Mission – Richard M. Hambly	25
Repeatable Multi-night Zenith H I Drift Scans with a 2.1-m Amateur Radio Telescope in Glendora, California – Pablo Lewin	56
Solar Radio Activity During Spring 2026 - Whitham D. Reeve	68
NF Test: Callisto Test Tool - Whitham D. Reeve & Christian Monstein	76
21cm Wavelength Circular Patch Feed Disk Director Yagi Antenna – Alex Pettit.....	89
1m Yagi ERv1 Enhanced Reliability – Alex Pettit.....	107
Observation Reports.....	112
Brief Report on First Light Observations with 134cm VLF Antenna - Dr Andrew Thornett.....	112
Journal Archives and Other Promotions.....	121
What is Radio Astronomy?	122
Administrative.....	123
Officers, directors, and additional SARA contacts	123
Resources.....	125
Great Projects to Get Started in Radio Astronomy.....	125
Radio Astronomy Online Resources	127
SARA Brochure.....	131

President's Page



Excellent series of articles and reports this month!

We are seeing our members support the Artemis moon program, do advance 21cm and maser observations, and develop new engineering approaches to observe.

Keep up the great work on this fabulous hobby!

Don't forget to sign up for the Eastern Conference! There are only so many rooms available.

On a Business Note:

- Nominations for the 2026 elections – need President, VP, and Treasurer as well as 4 board of directors. These are 2 year positions. This looks great on your resume since we are an international 501(3C) organization.
- Volunteer positions needed – we are in need of help with the following committees:
 - Membership
 - Treasurer Assistant
 - Journal
 - Store
 - Grant

Contact me if you are interested!

Please see below for more information on SARA election and positions.

Thanks!

Rich

Dr. Richard Russel

SARA President

Editor's Notes

We are always looking for basic radio astronomy articles, radio astronomy tutorials, theoretical articles, application and construction articles, news pertinent to radio astronomy, profiles and interviews with amateur and professional radio astronomers, book reviews, puzzles (including word challenges, riddles, and crossword puzzles), anecdotes, expository on "bad astronomy," articles on radio astronomy observations, suggestions for reprint of articles from past journals and other publications, and announcements of radio astronomy star parties, meetings, and outreach activities.

Subscribe to the SARA YouTube Channel

SARA has a YouTube channel at: <https://www.youtube.com/@radio-astronomy>

Don't forget to LIKE  the videos! It helps with the YouTube distribution algorithm.

We are also looking to add content to the site. Anyone who wants to help produce a series of 5 - minute videos relating to radio astronomy technology or observations please contact me. (drrichrussel@netscape.net)

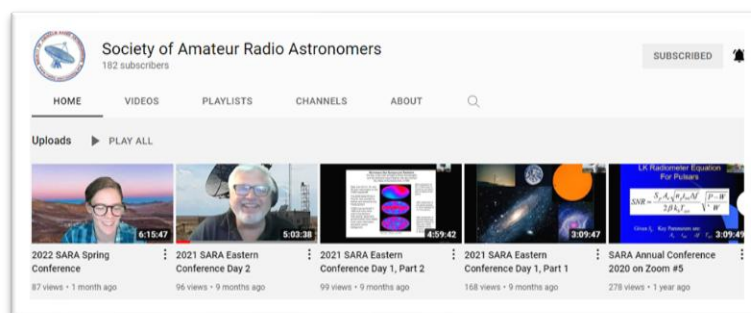

Observation Reports

We are now accepting 1-2 page observation reports. These reports should include the astronomical object's RA/DEC plus UTC of the observation. Also include the telescope configuration, process used to observe the object and results. Picture of the setup and plots of the observation are a plus to the report.

If you would like to write an article for Radio Astronomy, please follow **the newly updated Author's Guide** on the SARA web site:

http://www.radio-astronomy.org/publicat/RA-JSARA_Author's_Guide.pdf.

Let us know if you have questions; we are glad to assist authors with their articles and papers and will not hesitate to work with you. You may contact your editors any time via email here: edit@radio-astronomy.org.

The editor(s) will acknowledge that they have received your submission within two days. If they do not reply, assume they did not receive it and please try again.

Please consider submitting your radio astronomy observations for publication: any object, any wavelength. Strip charts, spectrograms, magnetograms, meteor scatter records, space radar records, photographs; examples of radio frequency interference (RFI) are also welcome.

Guidelines for submitting observations may be found here: <http://www.radio-astronomy.org/publicat/RA->

Society of Amateur Radio Astronomers (SARA)

**2026 SARA & Radio Jove Eastern Conference
August 1 (Sat) – August 5 (Wed) 2026
Green Bank Observatory (GBO) West Virginia (WV)**



Abstracts are being requested up until the end of April 2026!!!

Submit an abstract to vicepresident@radio-astronomy.org to present at the Conference

Block your calendars and start thinking about this year's travels. The 2026 Eastern Conference has been set to occur the first week in August 2026 back in Green Bank WV!

- 2026 SARA and Radio Jove Eastern Conference
- August 1 (Sat) – August 5 (Wed) 2026
- Green Bank Observatory (GBO) West Virginia (WV)

We will be following a similar format as years past. For example:

- Saturday (8/1): Guided tours of public exhibits, Dave Lacko and Jay Wilson discussion on "What is Radio Astronomy Anyhow?", hands on workshop assembling Scope in a Box and eZRA software
- Sunday (8/2): hands on workshop for 40' telescope and 20-meter telescopes, with attendees able to plan and make observations
- Monday – Tuesday: Technical discussions
- Wednesday (8/5): Guest Speaker and technical tours of GBO
- Evenings: Drake lounge discussions, flea market, and observations using Scope in a Box, Radio Jove, Super SID, 40', 20 meter telescopes

Any comments and/or suggestions please reach out to the committee chair Marcus Fisher (vicepresident@radio-astronomy.org)

2026 SARA Officers and Board Members Nominations

As required by Article VII, Section 3 of SARA By-Laws (see below), this is the official call for nominations for SARA officers and board members.

If you are interested in running for office and would like to know more about the positions, please contact a board member, SARA President Rich Russel, or SARA Secretary Brian O'Rourke.

The requirement to be on the board is to attend the board meetings at the annual meeting and to actively participate in board-related activities.

If you are unable to attend the annual meetings, then the director at large position may be for you. This position is a full board position except that attending the annual meeting is not required.

The following positions will be up for election in August 2026: President, Vice President, Treasurer, and four Board of Director members.

If you would like to run for one of the available SARA Officer or Board positions, please send a note to Secretary Brian O'Rourke with a copy to President Rich Russel. Please include a short biography and head shot photo. The biography and photo will be used to inform the membership about who you are.

Contact information:

Brian O'Rourke: brian.chad@gmail.com

Dr. Rich Russel: drrichrussel@netscape.net

Please Note: It is important to get someone's permission before nominating them!

Text from the By-Laws: Article VII, Section 3:

Elections of Directors and Officers will be accomplished by the President placing an initial call for nominations in "The Journal" no less than ninety (90) days prior to the regular scheduled meeting. Two (2) nominations from different members will be required to nominate a member for an office. No less than thirty (30) days prior to this meeting (in a newsletter issued prior to the meeting), the President will place a notice of the results of the nominations in "The Journal", along with a ballot for the members to use to vote for the nominee of their choice. This ballot will be forwarded to the Secretary for collection and counting at the regular meeting.

Responsibilities of President:

1. Preside over all business of the Society.
2. Appoint committees as needed, and will be an ex-officio member of all committees.
3. Act as the official spokesman for the Society.
4. Perform all other duties normally assigned to the office of a President.

Responsibilities of Vice President:

1. Preside and assume the duties of the President in any case where the President cannot assume his normal duties, or at the request of the President.
2. Promote the Society in the areas of public relations, information, and membership recruiting.
3. Responsible for organizing and conduction the annual meeting.

Responsibilities of Treasurer:

1. Deposit funds into bank account in a timely fashion.
2. Manage PayPal account.
3. Record all financial transaction.
4. Pay all SARA bills on time.
5. Reconcile bank and PayPal statements.
6. File Form 990EZ with IRS by November 15th
7. Maintain membership records.
8. Send renewal notice to members.
9. Email members when a new Journal is available.
10. Send list of new members to be in next Journal.
11. Handle sales of SARA items.

Responsibilities of Directors:

The Director needs to respond to and vote on business brought before the Board of Directors. This includes the SARA annual meeting, email meetings, and teleconference meetings such as Zoom. The requirement to be on the board is to attend the board meetings at the annual meeting and to actively participate in board-related activities. For a more detailed list of responsibilities, See Article VII, Sections 4 through 8.

[If you have any questions or comments, please email the Secretary at brian.chad@gmail.com]

SARA Student & Teacher Grant Program

All, SARA has a grant program that is, sad to say, very underutilized. We will provide kits or money for students and teachers, including college students, to help them with a radio telescope project. SARA can supply any of the following kits:

- [1] SuperSID
- [2] Scope in a Box
- [3] Radio Jove kit
- [4] Inspire
- [5] Sky Scan

We can also provide up to five hundred dollars (\$500.00 USD) for an approved radio telescope project.

We have on occasion provided more money based on the merits of the project and the SARA Grant Committee approval.

More information on the grant program can be found at the URL below.

[SARA Student and Teacher Project Grants | Society of Amateur Radio Astronomers \(radio-astronomy.org\)](https://www.sara.org/Grants)

All that is required is the SARA grant request form to be filled out and sent in. If it needs more work for approval, we will work with the students to help ensure their success.

Please pass the word that SARA will fund any legitimate radio telescope project anywhere in the world.

If you have a question, contact me at crowleyti@hotmail.com .
Tom Crowley - SARA Grant Program Administrator

Drake's Lounge Australia

This new zoom forum is geared to the Melbourne, Australia time zone (UTC+10) in order to improve coordination with our Australia, New Zealand, and Japanese members. The meetings are scheduled for the 4th Friday of every month, 9 AM Melbourne time. A zoom announcement will be sent out to all SARA members before the meeting.

Radio Telescope Observation Party (RTOP)

RTOP is designed to demonstrate how to take observations using various radio telescopes. It will also cover how to record and analyze data.

RTOP is every month on the 1st Sunday at 2 pm Eastern time (1800 UTC). ZOOM email notifications will be sent to all members.

Drake's Lounge

Join the SARA community as we discuss the latest astronomy and radio astronomy news. The lounge also provides a forum to share and get advice on your radio astronomy projects from very experienced amateur radio astronomers.

Drake's Lounge is every month on the 3rd Sunday at 2 pm Eastern time (1800 UTC). ZOOM email notifications will be sent to all members.



British Astronomical Association
Supporting amateur astronomers since 1890
Radio Astronomy Section



Director: Paul Hearn

The Radio Astronomy Section aspires to encourage and support the construction of radio telescopes by amateurs, their use for observing programmes, and the development of a deeper understanding of the science underlying what is being observed. Programmes can be aimed at any radio astronomical phenomenon, at any radio frequency. This encouragement will be through the operation of continuing group programmes, and through building communication and information exchange between individuals and groups pursuing their own projects. The main purpose of the Group is to act as a reservoir and clearing house for information on radio telescope design, construction and debugging, and how to use these instruments effectively. This will include the discussion of observing techniques and data analysis. Members should be able to exchange ideas, give advice and help each other. Establishing a pool of design information and software suitable for use in observing and data processing is a priority.

BAA Radio Astronomy Section Seminar programme.

These seminars are on Zoom, if you are not on the BAA RA Section email list please contact Paul Hearn – Section Director – paul@hearn.org.uk

Friday May 1st 19:30 BST (18:30 UTC)

Diane Swan Post graduate student University of Lancashire
(formally University of Central Lancashire)

What radio observation of core collapse supernovae tells us about the life and death of the star

Friday June 5th 19:30 BST (18:30 UTC)

Eduard Mol Creative Amateur Radio Astronomer -- The story of the modular 3 metre dish
Many amateur radio astronomers wish to have a large dish: after all, the greater the aperture, the better the sensitivity and resolving power. However, a larger dish also means a lot more practical issues, ranging from higher wind load to disgruntled neighbors... furthermore, weatherproofing a radio telescope to set it up outside permanently is challenging, especially in our wet climate. Can we have a 3 metre dish without many of these drawbacks?

Friday July 10th 19:30 BST (18:30 UTC) Dr Tim Molteno TART

The Transient Array Radio Telescope: An open-source aperture synthesis imaging radio telescope
Dr Tim Molteno is a Senior Lecturer in Physics at the University of Otago, New Zealand, Senior Research Associate, Physics and Electronics, Rhodes University, South Africa, and Director of the Electronics Research Foundation. He is an expert on Nonlinear Dynamics, Bayesian Inference,

Measurement, Electronics, Signal Processing and Radio Astronomy Instrumentation. Twelve years ago he founded the Transient Array Radio Telescope (TART) project. Tim has contributed code to many parts of the TART project, his recent contributions include tart-cargo, disko, tart2ms, spotless, the version 3 hardware for the correlator, motherboard and radio-board as well as the current calibration system.

There are three additional on-line meetings and discussion hosted by Andy Thornett. H-Line instruments and observation, GNU Radio, and muon instruments and observation. If you are interested please contact Andy (andrew@thornett.net).

[Join the RA conversation](#)

[Join the muon conversation](#)

[Join the UK Beacon conversation](#)

[Society of American Radio Astronomers](#)

[UK Radio Astronomy Association \(UKRAA\)](#)

[BAA RA YouTube channel](#)

Paul Hearn

BAA Radio Astronomy Section Director

UKRAA Trustee

||| British Astronomical Association |||

https://britastro.org/section_front/24

Where Art and Science Meet

Halfway to the Moon - The Bard of Lichfield

Halfway to the Moon.

The Bard of Lichfield, 5/4/2026.

The crew of the Artemis II mission to fly around the Moon has just produced a photograph showing the Earth fully lit in all its glory, as they looked back at it from halfway to the Moon. This raised the question on Facebook how the Earth could be fully lit, when at the same time we were observing a full Moon from Earth?

The answer is that the Moonside of the Earth is lit from the Moon, whilst the Sun shines from behind the Earth onto the Earthside (nearside) of the Moon.

Halfway to the Moon, they drift in hush,
Engines quieted to a memory of flame—
Crew of Artemis II suspended in black,
Between two worlds that refuse to dim.

Behind them, Earth—no longer a horizon—
But a whole, breathing sphere,
Oceans poured in blue, clouds softly turning—
And somehow, impossibly, fully lit.

Not by the Sun's direct command,
But by a gentler hand.

Ahead, the Moon burns—perfect, entire,
A flawless circle of silver fire,
Every crater alive with brilliance—
The same full Moon seen from Earth below,
Hanging in night skies, complete and unbroken.

This is the wonder they witness:

The Moon—full to every eye on Earth—
Still gathers the Sun in total,
Holds nothing back, reflects without loss—
And casts that fullness outward.

So, Earth answers in kind.

Its night erased by borrowed light,

Its shadow softened into day,
Becomes, to these travelers,
Another full world—quietly aglow.

Thus, both are whole at once:
The Moon, fully lit by the distant Sun,
The Earth, fully lit by the nearer Moon—
A perfect symmetry of light and grace.

And in that fragile midpoint,
Where distance rewrites the rules of shadow,
They see what few ever will:

A full Moon for those on Earth,
A full Earth for those in flight—
And between them, a silent exchange,
Where nothing is lost,
And everything shines.

SuperSID



SuperSID

*Collaboration of
Society of Amateur
Radio Astronomers
and Stanford Solar
Center*



- Stanford provides data hosting, database programming, and maintains the SuperSID website
- Society of Amateur Radio Astronomers (SARA) sells the SuperSID monitors for 48 USD to amateur radio astronomers, and the funds are then used to support free distribution to students all over the world (image below as of Fall 2017)
- Jonathan Pettingale at SARA is responsible for building and shipping the SuperSID monitor kits: SuperSID@radio-astronomy.org
- SuperSID kits may be ordered through the SARA SuperSID webpage: <http://radio-astronomy.org/node/210>
- Questions about the SuperSID project may be directed to Steve Berl at Stanford: steveberl@gmail.com
- Jaap Akkerhuis at Stanford is responsible for the SuperSID software and SARA has provided financial support for his efforts
- SuperSID website hosted by Stanford: <http://solar-center.stanford.edu/SID/sidmonitor/>
- SuperSID database: <http://sid.stanford.edu/database-browser/>
- The data is searchable by time, station, date, and multiple plots may be placed on the same graph for comparison.

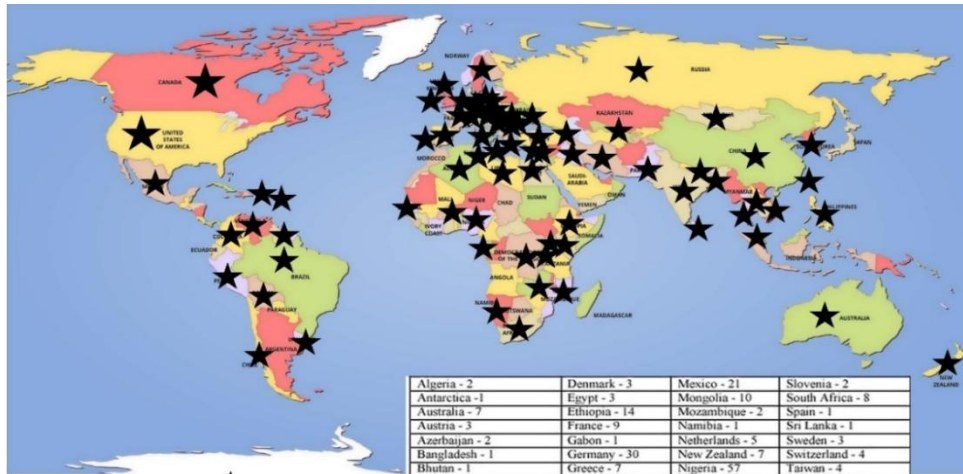

★
**SID Monitor
 Distribution**
 1078 instruments
 82 countries
 7 continents

Algeria - 2	Denmark - 3	Mexico - 21	Slovenia - 2
Antarctica - 1	Egypt - 3	Mongolia - 10	South Africa - 8
Australia - 7	Ethiopia - 14	Mozambique - 2	Spain - 1
Austria - 3	France - 9	Namibia - 1	Sri Lanka - 1
Azerbaijan - 2	Gabon - 1	Netherlands - 5	Sweden - 3
Bangladesh - 1	Germany - 30	New Zealand - 7	Switzerland - 4
Bhutan - 1	Greece - 7	Nigeria - 57	Taiwan - 4
Bolivia - 1	Guyana - 1	Pakistan - 4	Thailand - 5
Bosnia-Herzegovina - 2	Hungary - 1	Peru - 10	Tunisia - 9
Brazil - 11	India - 33	Philippines - 3	Turkey - 2
British Virgin Islands - 1	Indonesia - 2	Poland - 2	Uganda - 5
Bulgaria - 2	Iran - 4	Portugal - 3	UK - 32
Burkina Faso - 1	Iraq - 1	Rep of Congo - 3	Uruguay - 9
Canada - 33	Ireland - 9	Romania - 4	US Virgin Islands - 2
Chile - 1	Italy - 42	Russia - 3	USA - 491
China - 38	Kenya - 23	Rwanda - 1	Uzbekistan - 2
Columbia - 9	Korea (South) - 2	S Africa - 4	Venezuela - 2
Croatia - 7	Lebanon - 11	Senegal - 1	Vietnam - 1
Cyprus - 1	Libya - 1	Serbia - 1	Zambia - 2
Czech Republic - 1	Malaysia - 19	Singapore - 3	
D Rep of Congo - 4	Malta - 1	Slovak Repub - 2	

For official use only

Monitor assigned: _____

Site name: _____

Country: _____

SuperSID Space Weather Monitor

Request Form

Your information here	
Name of site/school (if an institution):	
Choose a site name: (3-6 characters) No Spaces	
Primary contact person:	
Email:	
Phone(s):	
Primary Address:	Name School or Business Street Street City State/Province Country Postal Code

Shipping address, if different:	Name		
	School or Business		
	Street		
	Street		
	City	State/Province	
	Country	Postal Code	
Shipping phone number:			
Latitude & longitude of site:	Latitude: _____ Longitude: _____ _____		

I understand that neither Stanford nor the Society of Amateur Radio Astronomers is responsible for accidents or injuries related to monitoring use. I will ensure that a surge protector and other lightning protection devices are installed if necessary.

Signature: _____ **Date:** _____

I will need:

<i>What</i>	<i>Cost</i>	<i>How many?</i>
SuperSID distribution USB Power (no options)	\$48 (assembled)	
USB Sound card 96 kHz sample rate (<i>or provide this yourself</i>)	\$40 (<i>optional</i>)	
Antenna wire (120 meters) (<i>or you can provide this yourself</i>)	\$23 (<i>optional</i>) with connectors attached and tested	
RG 58 Coax Cable (9 meters) (<i>or provide this yourself</i>)	\$14 (<i>optional</i>) with connectors attached and tested	
<i>Shipping</i>	US \$12 Canada & Mexico \$40 all other \$60	
	TOTAL	\$

_____ I have included a \$_____ check (payable to SARA)

_____ I will make payment thru www.paypal.com to treas@radio-astronomy.org

or

____ If you are a Minority-serving institution, in a Developing or economically deprived nation, and/or you are using the monitor with students for educational purposes, you may qualify for obtaining a monitor at reduced or no cost. Check here if you wish to apply for this designation. Then tell us how you want to use the SuperSID monitor. Include type of site, number of students involved, whether public or private school, grade levels, etc. and describe your program. The goal of the SuperSID project is to provide as many students with systems as possible. If you are able to pay for a system, even if you qualify for a free one, please do so and help support our goal.

For more details on the Space Weather Monitor project, see: <http://sid.stanford.edu>

To set up a SuperSID monitor you will need:

¹ Access to power and an antenna location that is relatively free of electric interference (could be indoors or out)

² A **PC**** with the following minimal specifications:

- a. A sound card that can record (sample) up to 96 kHz, or a USB port to connect such a sound card (for North and South America)
 - i. All other countries can use AC97 sound card with 48 kHz record (sample) rate. Most computers made after 1997 will have AC97.
- b. Windows 2000 or more recent operating system
- c. 1 GHz Processor with 128 mb RAM
- d. Ethernet connection & internet browser (desirable, but not required)
- e. Standard keyboard, mouse, monitor, etc.

³ An inexpensive antenna that you build yourself. You'll need about 120 meters (400 feet) of **insulated** wire. Solid wire is easier to wind than stranded. Magnet wire will work but be more fragile. You can use anything from #18 to #26 size wire. The antenna frame can be made of wood, PVC pipe, or similar materials. We'll provide instructions. You can purchase the wire from us or obtain your own.

⁴ RG58 coax cable with a BNC connector at one end to run from the antenna to the SuperSID receiver. 9 meters is recommended, but the length will depend on where you place the antenna. You can purchase the coax from us or obtain your own.

⁵ Surge protector and other protection against a lightning strike

Return this form to: SuperSID@radio-astronomy.org

Announcing Radio JOVE 2.1

The Radio JOVE Team



Radio JOVE students and amateur scientists from around the world observe and analyze natural radio emissions of Jupiter, the Sun, and our galaxy using their own easy to construct radio telescopes.

Our Project announces Radio JOVE 2.1, where participants assemble a 16-24 MHz radio spectrograph to observe solar, Jupiter, Galactic, and Earth-based natural radio emissions and share their observations with fellow participants.

In the Beginning

Radio JOVE started as a NASA sponsored educational outreach project in 1999. We developed a radio telescope kit suitable for receiving signals from Jupiter, the Sun, the Galaxy, and Earth-based radio emissions. The original kit comprised a radio receiver (RJ1.1) and a dual dipole antenna for 20.1 MHz. An important goal was to teach electronic principles including how to build, solder, and assemble the radio receiver and antenna.

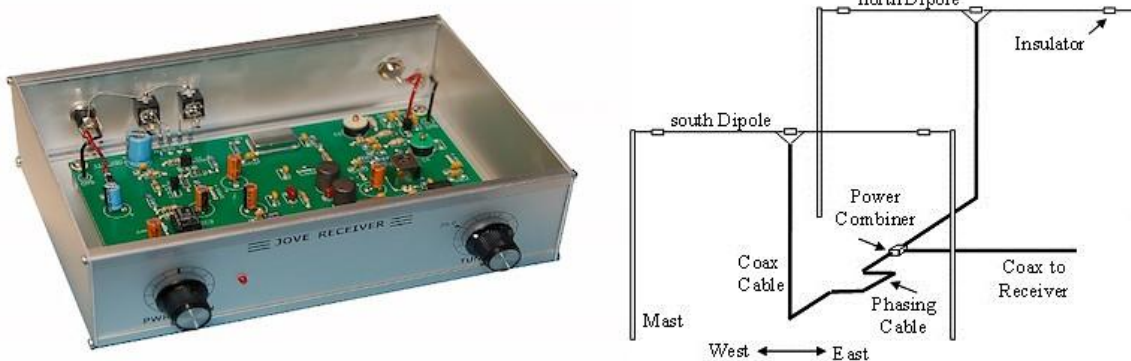

Figure 1. A Radio JOVE RJ1.1 receiver and a schematic of the dual-dipole antenna.

In addition to the hardware, three software packages were developed. These were Radio Jupiter Pro (Jupiter emission prediction program), Radio-SkyPipe (strip chart program) and Radio Sky Spectrograph (control and display of radio spectrograph data).

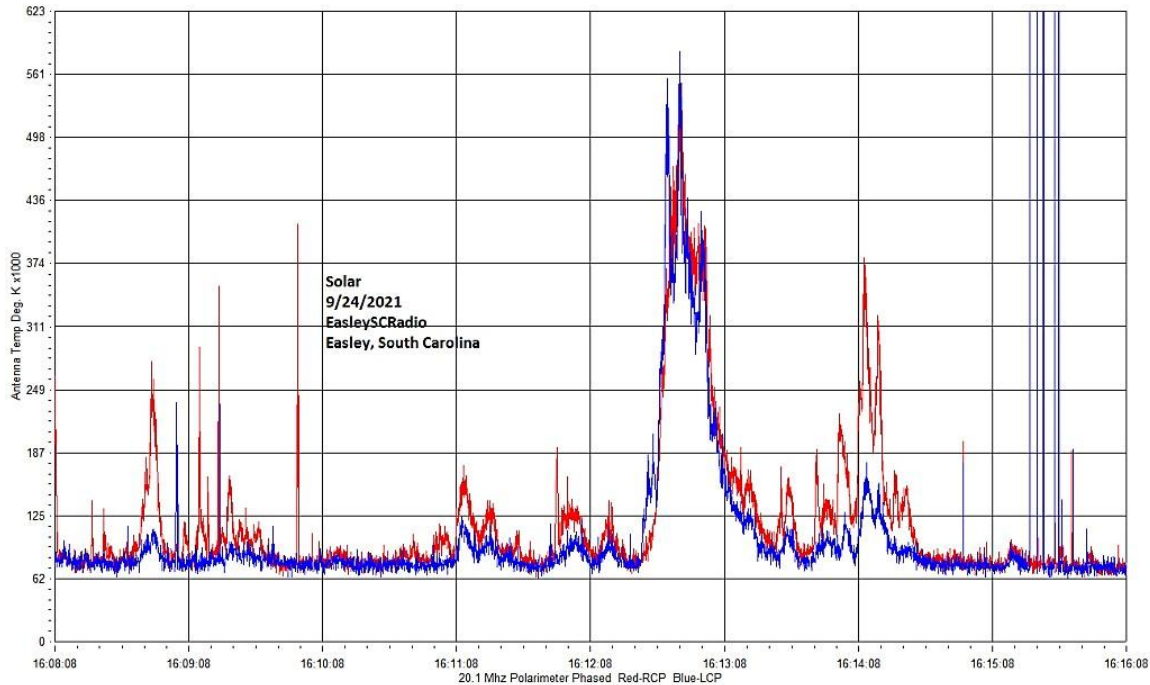

Figure 2. A SkyPipe strip chart showing multiple solar bursts using a JOVE receiver.
John Cox, SC.

The Growth of Radio JOVE

As of Autumn 2021, over 2,500 kits have been sold at cost to schools and individuals around the world. Thousands of data submissions from observers have been made to the Radio JOVE data archive.

The Radio JOVE web site has always provided a wealth of information describing observation methods and various educational materials intended to teach radio astronomy techniques and scientific methods. Biannual newsletters are produced and several telephone help sessions are held each year.

A sub-group of experienced observers known as the Spectrograph Users Group (SUG) evolved from the core JOVE group. These observers developed data collection and analysis techniques using more advanced equipment and techniques. SUG members have contributed to articles published in peer-reviewed scientific journals. This group remains active under the Radio JOVE listserv at <https://groups.io/g/radio-jove/>.

Moving Forward with New Technology

In the past, Radio JOVE provided the hands-on experience of building a radio kit. We have many RJ1.1 receivers in operation successfully contributing scientifically valuable data. It has, however, become increasingly difficult to obtain parts for the RJ1.1 receiver kits and we therefore decided to replace the RJ1.1 receiver with a new SDR-based design for the receiver portion of our radio telescope kits. While we continue to support the hardware and software for the original RJ1.1 receivers, the only kits now available for purchase from Radio JOVE contain this newly designed system.

In recent years, new technologies have made software defined radios (SDRs) ever more affordable. These radios can operate on a single frequency like the original JOVE receiver but can also generate spectrograms which depict radio activity as a function of both time and frequency. Such displays offer new insights into our studies of the Sun, Jupiter, the Galaxy, and both natural and artificial Earth-based radio emissions.

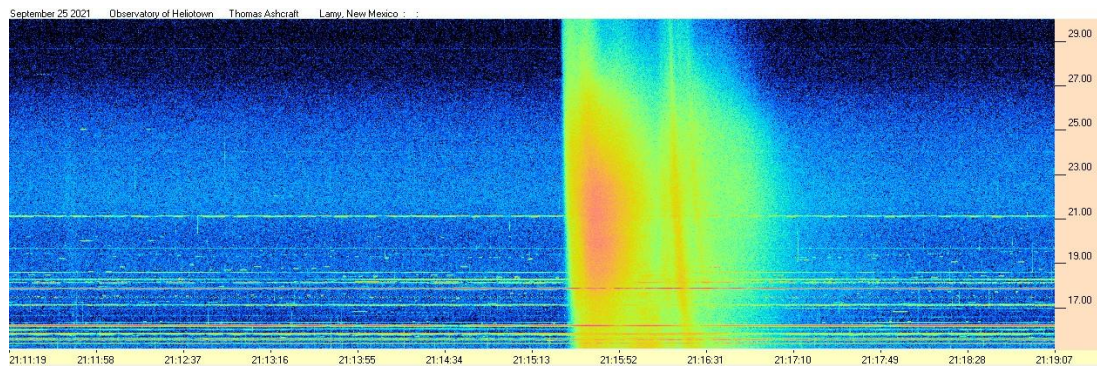

Figure 3. Radio spectrogram showing multiple solar bursts received by Tom Ashcraft in New Mexico. Horizontal scale is time and the vertical scale is frequency. Amplitude is displayed using different colors corresponding to the strength of signals.

Radio JOVE continues to sell radio telescope packages including an antenna, receiver, and software; however, the receiver is now a commercially built SDR.



Figure 4. As of 2025, Radio JOVE has moved from the SDRPlay RSP1A SDR to the RSP1B. The JOVE team will continue to provide support both instruments as used in our radio astronomy program. Not all SDR types can be supported, but it is our intent to provide support for some other SDRs as they become available during this period of rapid SDR development.

It continues to be our goal to introduce new observers to the scientific method and help them experience the thrill of receiving cosmic radio signals. Through a series of educational training modules and observing and analysis projects we aim to guide new observers to levels where they can contribute to Citizen Science projects.

We continue to support our large user base that uses JOVE RJ1.1 receivers – both in terms of technical support for the receivers but also with new and exciting observing projects for both RJ1.1 and SDR users.

We welcome both new and experienced observers to the JOVE 2.1 program as we share the excitement of receiving, studying, and understanding radio signals from our corner of the galaxy.

Please see the Radio JOVE web site at <https://radiojove.gsfc.nasa.gov> for more information.



RADIO JOVE 2.1 RADIO TELESCOPE KIT ORDER FORM

Order Online using PayPal™

* * * Please allow 2 to 3 weeks for delivery. * * *

IMPORTANT: Before you order the Jove receiver kit and/or the antenna kit, we suggest that you read the on-line manuals. You will need to provide additional materials and tools to complete the antenna. The cost of additional materials for the antenna support structure (masts, etc.) may be in the range of US\$75 to US\$100. Also note that the optimal antenna height can be up to 20ft, depending upon your latitude.

<p>Item # RJK2u – Complete 2.1 Kit: Receiver + Unbuilt Antenna Kit + Software</p> <p>This kit includes an SDRplay RSP1B, USB Cable, SMA/F adapter cable, unbuilt Antenna Kit (RJA), printed assembly manuals, and Radio-Sky Spectrograph (RSS) software.</p> <p>Note: Kit does not include antenna support structure.</p> <p>Price: \$306 + Shipping (See below for shipping)</p>	<p>Item # RJK2p – Complete 2.1 Kit: Receiver + Professionally Built Antenna Kit + Software</p> <p>This kit includes an SDRplay RSP1A, USB Cable, SMA/F adapter cable, Professionally Built Antenna Kit (RJA2), printed assembly manuals, and RadioSky Spectrograph (RSS) software.</p> <p>Note: Kit does not include antenna support structure.</p> <p>Price: \$472 + Shipping (See below for shipping)</p>
---	---

<p>Item # RJA – Unbuilt Antenna Kit</p> <p>The RJA Radio JOVE Antenna Kit includes a printed construction manual, stranded copper easy-to-solder antenna wire, ceramic insulators, RG-59 easy-to-solder coax cable, screw-on Fconnectors, and a power combiner.</p> <p>Note: Kit does not include antenna support structure. Assembly requires a soldering gun and other tools.</p> <p>Price: \$133 + Shipping (See reverse for shipping)</p>	<p>Item # RJA2 – Professionally Built Antenna Kit</p> <p>The RJA2 Radio JOVE Antenna Kit includes a printed installation manual, two professionally assembled dipole antennas constructed of #14 Copperweld wire with Budwig center insulators and center support rope attachment points, high quality RG-6 coax with pre-installed commercial grade connectors, and a power combiner.</p> <p>Note: Kit does not include antenna support structure.</p> <p>Price: \$299 + Shipping (See below for shipping)</p>
<p>Item # LTJ2 – Listening to Jupiter, 2nd Ed. by R. S. Flagg</p> <p>PDF download of Richard Flagg's book "Listening to Jupiter, 2nd Ed., 2005". The file is downloaded from a secure website.</p> <p>Price: \$10 + \$0 shipping (PDF file download)</p>	

Order Online at

https://radiojove.net/kit/order_form.html OR

Complete this form and mail with payment

Payment may be made by Credit Card via PayPal™, U.S. Check, U.S. Money Order, International Money Order in U.S. funds drawn on a U.S. bank, or Western Union Money Transfer made payable to **The Radio JOVE Project**. No bank-to-bank wire transfers are accepted. Purchase Orders are accepted from U.S. Institutions.

Send to: The Radio JOVE Project
1301 East Main St. MTSU Box 412
Murfreesboro, TN 37132, USA
email: chiggins@mtsu.edu
FEIN: 20-5239863

Item	Description	Quantity	Item Price	Shipping (see below)	Subtotal
RJK2u	Complete Radio JOVE 2.0 Kit Receiver + unbuilt Antenna		\$306		
RJK2p	Complete Radio JOVE 2.0 Kit Receiver + Professionally Built Antenna		\$472		
RJA2	Professionally Built Antenna-Only Kit		\$299		
RJA	Unbuilt Antenna-Only Kit		\$133		
LTJ2	Listening to Jupiter, 2 nd Ed., by R.S. Flagg (PDF download)		\$10	\$0	
Total:					

Shipping Fees for Radio JOVE: We ship all packages using USPS Priority Mail flat rate boxes.

U.S.A.: \$25.00

Canada: \$70.00

All Other International Shipping: \$110.00

Ship to: (Please print clearly)

Name: _____

Address: _____

City, State, Postal Code: _____

Province, Country: _____

Email: _____

Visit the Radio JOVE web site and fill out the team application form at

https://radiojove.net/sign_up_form.php even if you are just an interested individual so that you can receive important information about kit updates, online services, and activities within the project as they occur!

Rev 10/25

20-Apr-26

Doppler Tracking of Orion at DSES For the Artemis-II Mission



PREPARED BY RICHARD M HAMBLY, K0GD

Deep Space Exploration Society (DSES), <https://dses.science/>

Contents

Executive Summary.....	26
Introduction	27
Volunteers	28
Day-to-Day Details	28
Antenna and Control Console	30
The System 1 Upgrade	32
Time-Referenced Doppler Comparison and Residual Analysis	33
Doppler Comparison in Absolute Time	34
Residual Doppler in Absolute Time	35
Interpretation	36
Bias Term and Its Significance	37
Impact of Signal Processing Configuration on Bias	38
Receiving the Test Beacon.....	40
Additional Recording Sessions	41
Data collected 4/7/2026 by the Primary System	41
Data collected 4/8/2026 by the primary system:.....	42
Results.....	43
Lessons Learned.....	44
Appendix A: Light-Time Doppler Model Description	45
Appendix B: 10MHz Reference Calibration Run.....	48
Appendix C: Precision NTP Source	49

Executive Summary

The Deep Space Exploration Society (DSES) participated in the Artemis II tracking campaign using the 60-foot Plishner Radio Telescope. While full mission data capture objectives were not achieved due to a combination of hardware, software, and operational challenges, several successful reception intervals enabled detailed Doppler analysis of the Orion spacecraft signal.

The analysis demonstrates:

- Strong agreement between measured and modeled Doppler signatures using a one-way light-time geometric model
- Residual errors on the order of **4.65 Hz RMS (~0.6 m/s)**
- Identification of a **~1.3 ppm frequency bias**, consistent with receiver reference uncertainty or signal processing configuration

In addition, the campaign yielded critical insights into:

- Feed system optimization and pointing strategy
- SDR signal chain configuration and Doppler extraction methodology
- Operational coordination and software integration challenges

These results validate the fundamental capability of the DSES system for deep-space Doppler tracking while identifying key areas for improvement in future campaigns.

Introduction

The Deep Space Exploration Society (DSES) was selected by NASA to participate in a volunteer ground-station network supporting the Artemis II mission. As part of this effort, the 60-foot radio telescope at the Plishner Radio Telescope site was configured to receive S-band transmissions from the Orion spacecraft.

Artemis II launched on April 1, 2026, at 22:35 UTC. Initial observation opportunities were missed due to a misunderstanding of the tracking schedule. Subsequent efforts focused on preparing the antenna system, validating polarization alignment, and resolving feed and reference clock issues.

Over the following days, multiple teams worked to:

- Optimize feed positioning and focus
- Correct a failure in the 10 MHz reference distribution system
- Diagnose azimuth control issues and work around them to continue the mission
- Conduct manual tracking in the absence of full automation

Despite these challenges, several successful reception intervals were achieved, providing data suitable for Doppler analysis. These measurements form the basis of the technical results presented in this report.

Volunteers

This dedicated and hard working group of volunteers made this project possible.

The system 1 team; Glenn Davis W00FZ, Lewis Putman, Phil Gage K10NY.

The tracking teams: Bill Miller KCOFHN, Roger Oakey W3MIX, Mario Biendarra, Travis Lightsey, Richie Lary, Larry Stewart N7LWS, Anne Haney WOZDW, and Tom Eggers. The dedication of this team was evident especially considering that all the periods when the Orion capsule was in view were “third shift”, approximately midnight until a couple hours after sunrise.

Preparation and maintenance: Pat McDevitt KE0CQE, Myron Babcock KL7YY, Anne Haney WOZDW, Ray Uberecken AA0L, Paul Sobon N00T and Jeff Fladung KCOZJY.

Remote operators and engineering: Richard Hambly K0GD, Alex Nersesian K6VHF. During the mission, this team worked on improving the data collection software, upgrading it from software revision 1.6 to 1.13, constantly improving the software capabilities and resolving issues.

Day-to-Day Details

Artemis-II launched April 1, 2026, at 4:35 p.m. MDT (22:35 GMT). Due to a mix-up in our understanding, DSES did not record data during the first opportunity in the late evening of April 1st and early morning of April 2nd.

On April 2nd Roger Oakey and Lewis Putnam headed down to the site for the April 3rd morning observation. They spent the day working on the feed. They were only able to see a carrier from the Orion spacecraft at the start and end of the transmission period. They were able to verify that we were using the correct circular polarization at the feed - Orion transmits right hand circular polarization [RHCP] and because of the one reflection off the dish, we were correctly receiving on the feed's left hand circular polarization [LHCP] port.

On April 3rd Bill Miller, Mario Biendarra and Travis Lightsey took over. They resolved the feed's focus problem. In the early morning hours of the 4th a problem with the 10MHz reference distribution amplifier was discovered and rectified. Data from the Orion spacecraft was collected, some of which is shown in this document.

On April 4th Bill, Mario and Travis stayed on. Just after midnight on the 5th while slewing the dish to Orion's rising azimuth, the computer's azimuth control for the dish failed, allowing the azimuth to only move in one direction. Glenn Davis called in from Hawaii. Bill and Glenn worked to troubleshoot the problem. On the afternoon of the 5th Lewis Putman, Paul Sobon and Jeff Fladung went to the site with replacement parts to effect repairs.

On April 5th no data was collected in the morning. During the day Paul Sobon and Lewis Putnam worked to diagnose the problem. The tests ruled out problems with the Labjack LJTICK-DAC device, the Labjack U3 device, and the cable between DAC and motor controller. The conclusion was that the motor controller may have an issue.

On April 6th: no data was collected in the morning.

On April 7th no data was collected in the morning. Larry Stewart, Anne Haney, Richie Lary and Roger Oakey arrived on site.

On April 8th data collection was started soon after midnight. The dish was pointed by using manual controls, using the Artemis tracking software developed by Lewis Putman, Glenn Davis and Phil Gage, though we were unable to allow the computer to control the dish. Instead, using the manual dish controls we pointed the dish at approximately two-minute intervals. An hour or two in the primary computer and/or software appeared to freeze. Maintaining the spacecraft within the antenna beamwidth required continuous manual adjustments, highlighting the need for reliable automated tracking.

We did shifts of two people for two hours each, trading off between the two "on shift" as fatigue and/or boredom became an issue. This was Anne's suggestion and worked quite well. Richie Lary good-naturedly described keeping Artemis within the 3dB circle as "The world's most boring video game."

April 8th Richie Lary departed for a group lunch back in the 'springs and attending that lunch was Tom Eggers. Tom became interested enough in what we were doing to drive down that afternoon and join us. So, the group going into the next morning's data gathering was Larry Stewart, Anne Haney, Tom Eggers and Roger Oakey.

The morning of April 9th was like the morning of the 8th with two shifts of two people. This time the primary computer's software ran all night but an hour or two in it appeared that the signal from Orion was lost. Because of not having any visibility into what was happening with the secondary computer, the dish was kept on Artemis all night until there was an indication that the Azimuth drive had failed - about 7am in the morning. Turns out it was user error combined with a misdiagnosis on my part and the AZ drive is just fine (at least under manual control). So, the morning of the 9th we cleaned up, packed up, pulled the hardware out of the hub and headed home.

There was no data gathered the morning of the 10th.

Antenna and Control Console

This is the feed and custom electronics that was designed specifically for the Artemis-II mission mounted in the 60' dish's antenna's hub. For more information about the antenna feed design, see *DSES Antenna Study for the Artemis-II Mission* by Richard M Hambly, K0GD, 12-Apr-2026 at <https://dses.science/wp-content/uploads/Projects/Artemis-II/DSES-60-Foot Antenna Study for Artemis-II RevA.pdf>.



Below is the left section of the control console that contains the System 1 dish steering and secondary receiver and recording hardware.



Below is the center section of the control console showing the display for the primary receiver and recording system.



Below is the rightmost section of the control console showing the precision time and frequency system.

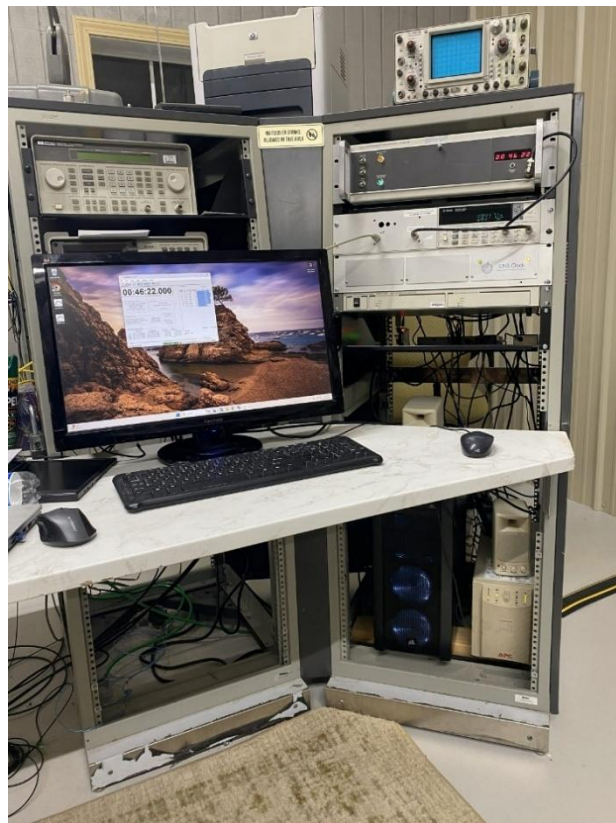

The System 1 Upgrade

System 1 is the system that is responsible for steering the DSES 60' dish. It has both manual and automatic controllers and both high and a low resolution sensors. The team responsible for the maintenance and software development of System 1 are Glenn Davis (W00FZ), Lewis Putman, Phil Gage (K10NY). In January 2026 the team began investigation ways to upgrade System 1 to use the Artemis-II data available on the Horizons web site. This was necessary as tracking data for the Orion capsule changes whenever there is a thruster burn. They considered “manual Ra/Dec pointing with sidereal track, Az/El Pointing (not great), or a valid 2 or 3 line element set (which provides automatic tracking).”

By late March the System 1 (dish positioning software) team rolled out a version of software which will track the capsule without human intervention, with a manual fallback in case of loss if internet connectivity which is required for automated tracking. This software regularly gathers new tracking data from the Horizons web site

(<https://ssd.jpl.nasa.gov/horizons/app.html#/>) to keep our pointing system up to date.

For more information, see *System 1 Ephemeris Tool Operation for Artemis II Tracking at the DSES Plishner Site* by Glenn Davis, Lewis Putman, and Phil Gage, 18-March-2026 available at https://dses.science/wp-content/uploads/Projects/Artemis-II/Ephemeris_Tool_Operation-v3.pdf

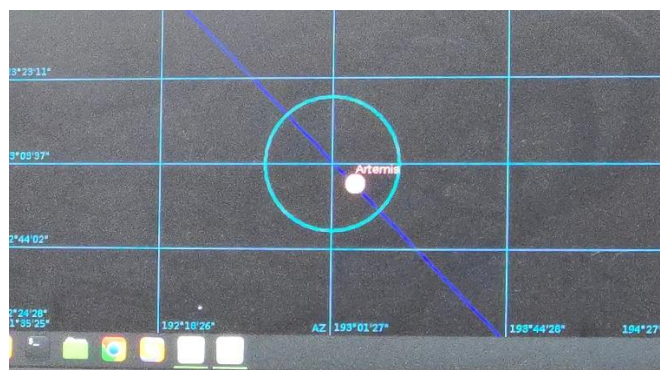
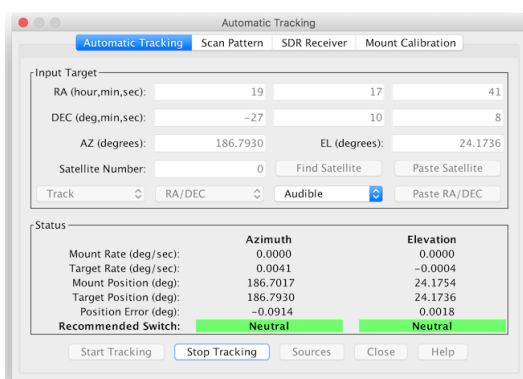

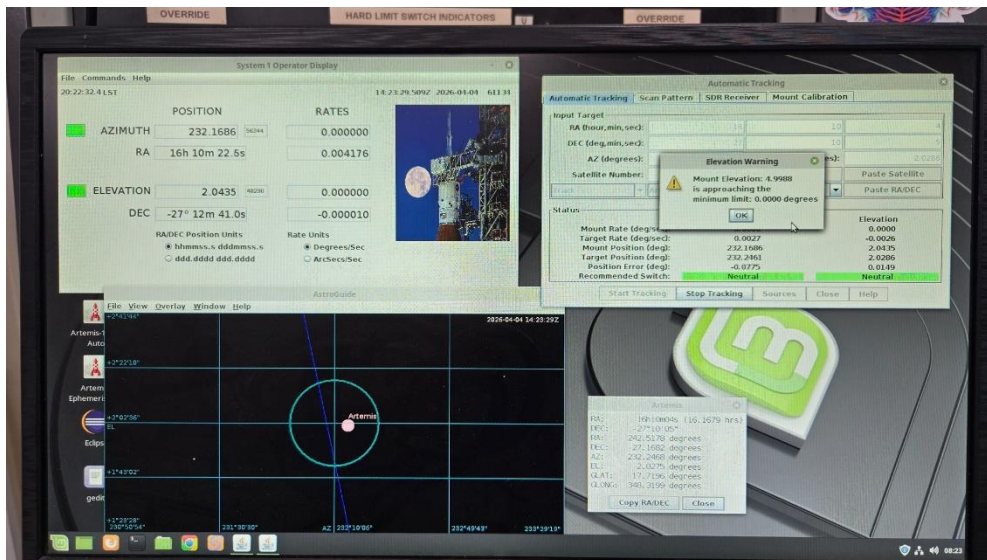

Time-Referenced Doppler Comparison and Residual Analysis

This section looks at the first solid data collected by DSES of the Orion spacecraft. It is analyzed carefully to verify that the data is indeed the Orion spacecraft and that the DSES hardware and data collection software is working as expected. The picture below represents a partial screen capture of the first successfully acquires signal from the Orion Capsule "Integrity" on April 4, 2026.

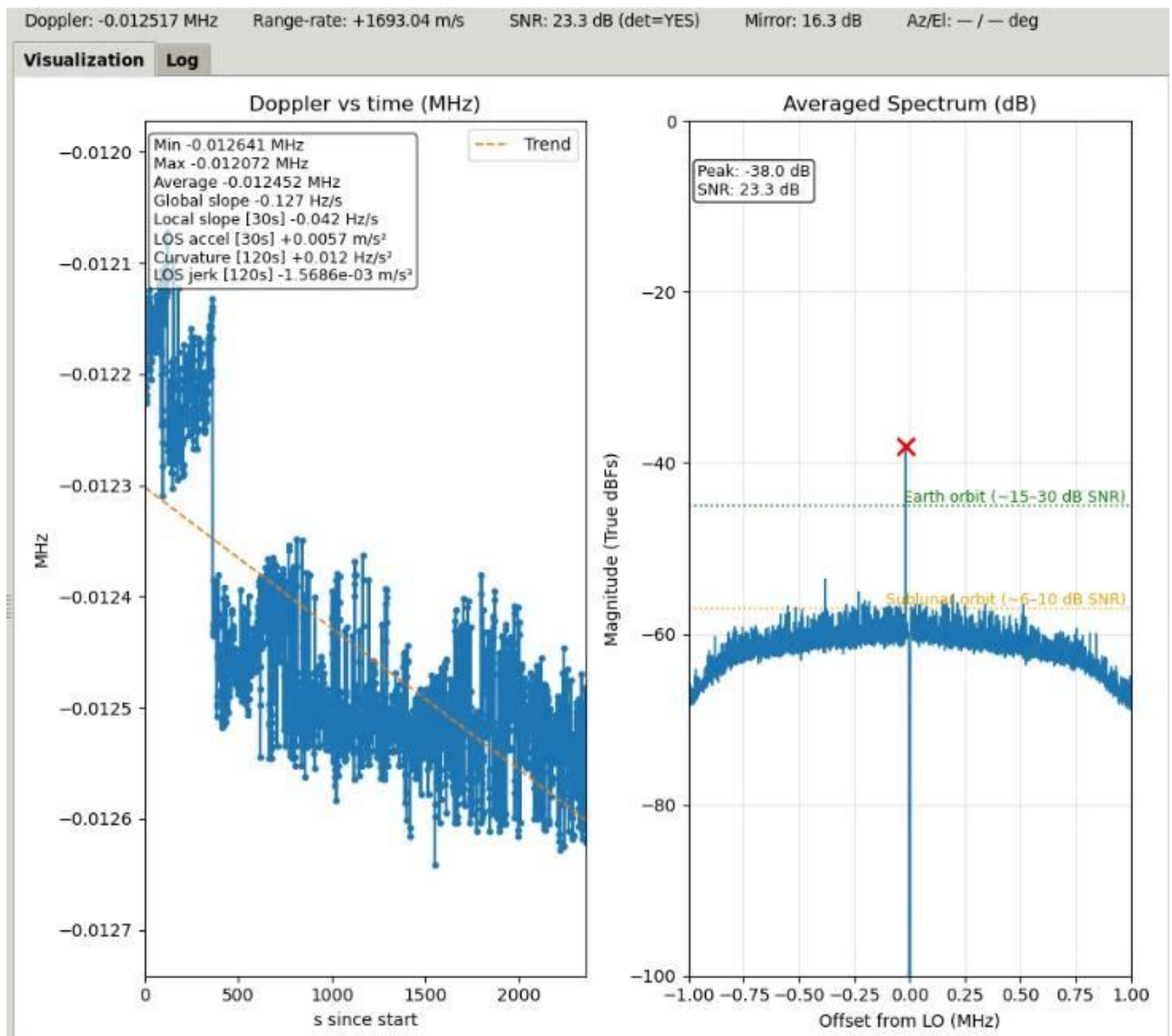

Doppler Comparison in Absolute Time

The figure *Artemis II / Orion Doppler Comparison at DSES* below presents the measured and modeled Doppler time histories plotted against absolute UTC time (HH:MM). The date of observation is indicated in the lower-left corner of the figure.

In this plot:

- The **measured Doppler** represents the frequency offset derived from the SDR signal processing chain.
- The **modeled Doppler** corresponds to the one-way light-time corrected geometric prediction, including bias and linear drift terms obtained through least-squares fitting.

Displaying the data in absolute time provides several advantages:

- It enables direct correlation with external datasets such as antenna pointing logs, SDR configuration events, and mission timelines.
- It allows verification of acquisition and loss-of-signal timing relative to predicted spacecraft visibility.
- It facilitates identification of any time-dependent anomalies that may be associated with station operations or environmental effects.

The close agreement between the measured and modeled curves over the full observation interval demonstrates that the dominant Doppler behavior is accurately captured by the light-time geometric model. Any remaining discrepancies are small compared to the total Doppler excursion and are further examined in the residual analysis.

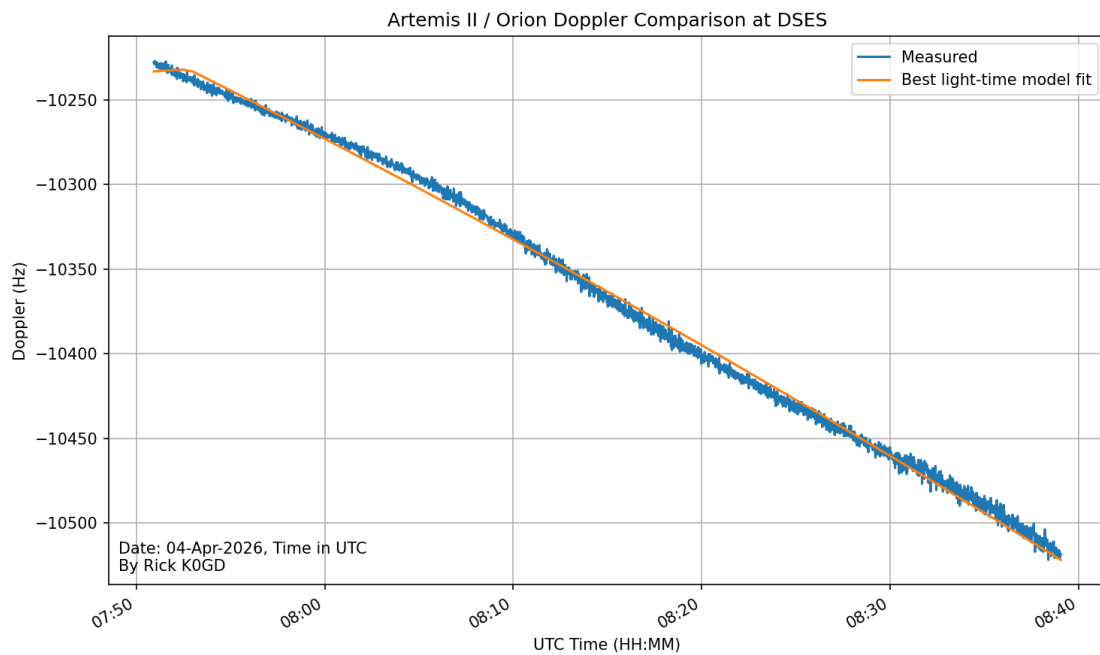

Residual Doppler in Absolute Time

The figure *Residual Doppler (Measured - Best Light-Time Model)* shows the post-fit Doppler residuals as a function of absolute UTC time, again with the observation date annotated in the lower-left corner.

The residual is defined as:

$$\epsilon(t) = f_{meas}(t) - f_{fit}(t)$$

where $f_{fit}(t)$ includes the geometric modeled Doppler along with fitted bias and drift terms.

Two curves are shown:

- The **raw residual**, which reflects the instantaneous difference between measurement and model.
- A **smoothed residual**, obtained via moving-average filtering, which highlights systematic trends by suppressing short-term noise.

Key observations from this figure include:

- The residual is bounded within a few Hz over the entire pass, with an RMS value of approximately 4.65 Hz.
- The residual exhibits a smooth, slowly varying structure rather than random noise, indicating that it arises from systematic effects not included in the current model.
- The absence of abrupt discontinuities or large excursions confirms the stability of both the measurement system and the time/frequency references during the observation.

Expressed in terms of equivalent line-of-sight velocity, the residual corresponds to approximately 0.6 m/s RMS, demonstrating a high level of agreement between measurement and prediction for an SDR-based receiving system.

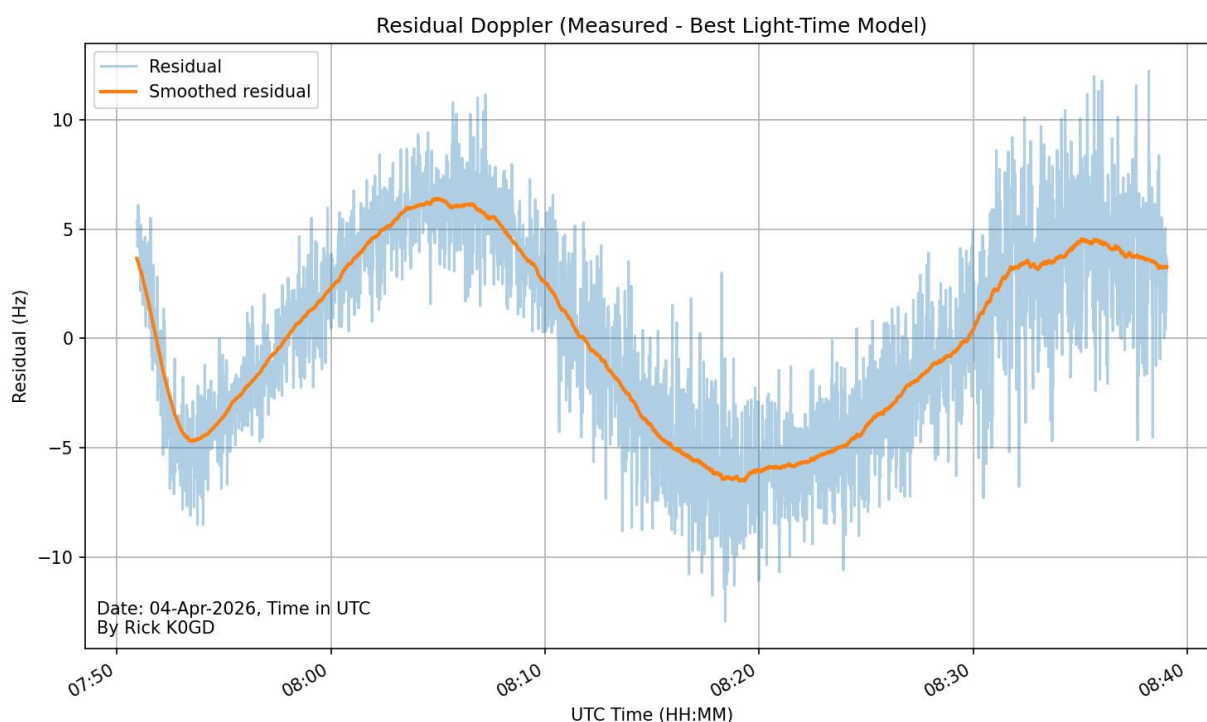

Interpretation

Together, these two figures above provide a comprehensive time-domain validation of the Doppler model:

- The comparison plot confirms that the primary Doppler signature of the spacecraft is accurately reproduced in both magnitude and temporal evolution.
- The residual plot isolates the remaining discrepancies, which are small and exhibit structured behavior consistent with higher-order effects such as measurement averaging, oscillator characteristics, or differences in observable definition.

Bias Term and Its Significance

A constant frequency offset (bias) is included in the Doppler model to account for systematic differences between the measured signal and the assumed nominal carrier frequency. The fitted model is expressed as:

$$f_{fit}(t) = f_{pred}(t) + b + (d \times t)$$

where:

- b is the **bias** (constant frequency offset)
- d is the linear drift term
- t is time

For the dataset analyzed, the estimated bias is:

$$b \approx -2935 \text{ Hz}$$

Physical Interpretation

The bias represents a **constant frequency offset** between the assumed nominal carrier frequency and the effective frequency reference of the measurement system.

Rearranging the model:

$$f_{0,eff} = f_0 - b$$

gives an implied effective carrier frequency of: $f_{0,eff} \approx \mathbf{2216502935 \text{ Hz}}$

This indicates that the measurement system behaved as though the carrier frequency were approximately **2.935 kHz higher** than the nominal value used in the model.

Fractional Frequency Error

The magnitude of this offset can be expressed as a fractional frequency error:

$$\frac{\Delta f}{f_0} \approx \frac{2935}{2.2165 \times 10^9} \approx 1.3 \times 10^{-6}$$

This corresponds to approximately: **~1.3 parts per million (ppm)**

Such an error is consistent with:

- an SDR local oscillator not fully locked to an external reference
- a misconfiguration of the reference clock input
- or a difference between the assumed and actual nominal carrier frequency

Impact on Doppler Analysis

The bias term has the following implications:

1. It does not affect Doppler shape

The bias is a **constant offset**, so it does not alter:

- the curvature of the Doppler profile
- the time evolution of the signal
- the comparison of measured versus predicted dynamics

Thus, the **agreement in Doppler shape remains valid** even in the presence of a large bias.

2. It must be removed for accurate comparison

Without removing the bias:

- the measured and predicted curves would be separated by several kHz
- the comparison would be dominated by a constant offset rather than dynamic agreement

Fitting and removing the bias allows the analysis to focus on the **true Doppler behavior**.

3. It is largely instrumental, not physical

The magnitude and constancy of the bias strongly indicate that it arises from the **receiver system**, rather than the spacecraft or propagation effects.

Specifically, the observed offset is consistent with:

- a small fractional frequency error in the SDR reference
- equivalent to approximately 13 Hz error at a 10 MHz reference

This is typical of an SDR operating without a properly locked external frequency standard.

Relationship to Residual Error

After removal of the bias (and drift), the remaining Doppler residual is approximately: **RMS \approx 4.65 Hz**

This demonstrates that:

- the **bias accounts for the dominant systematic offset (\sim 2935 Hz)**
- the remaining error is **three orders of magnitude smaller** and reflects higher-order effects

Summary

The fitted bias term represents a constant frequency offset of approximately **-2935 Hz**, corresponding to a fractional error of **\sim 1.3 ppm**. This offset is consistent with receiver frequency reference uncertainty and does not affect the validity of the Doppler shape comparison. Removal of the bias enables accurate evaluation of the Doppler model, revealing a much smaller residual error that reflects second-order effects rather than fundamental modeling or measurement errors.

Impact of Signal Processing Configuration on Bias

Relationship to SDR Processing Logic

The observed bias of approximately **-2935 Hz** must be interpreted in the context of the Doppler extraction equation implemented in the data collection software:

$$doppler = (f_{center} + f_{FFT}) - f_0 - f_{dc_{offset}}$$

This formulation requires that all frequency offsets applied within the SDR signal chain (e.g., LO shifts, DC avoidance offsets, or digital frequency translations) are **accounted for exactly once** in the Doppler computation.

Any mismatch between:

- how offsets are applied in the signal chain, and
- how they are removed in the Doppler equation

will introduce a **constant frequency bias**.

Potential Source of Bias in Previous Configuration

In the configuration used for this measurement:

- $f_{center} = 2216.505 \text{ MHz}$
- $f_{dc_offset} = 5 \text{ kHz}$

the intended behavior was:

$$(f_{center} - f_0) = +5 \text{ kHz and } f_{dc_offset} = 5 \text{ kHz}$$

so that the offsets cancel.

However, this approach depends critically on:

- the SDR applying the LO/DC offset exactly as assumed
- the FFT frequency axis being referenced consistently
- the software subtracting the correct offset value

If any of these conditions are not met, the result is a **systematic frequency error on the order of the offset itself (kHz-scale)**.

Revised Configuration and Its Advantages

The software was updated by Alex Nersesian and will be used in the next data collection session. It simplifies the processing chain:

- $f_{center} = 2216.520 \text{ MHz}$
- $f_0 = 2216.500 \text{ MHz}$
- $f_{dc_offset} = 0$
- DC avoidance handled via spectral placement rather than explicit correction resulting in:

$$doppler = (f_{center} + f_{FFT}) - f_0$$

or equivalently:

$$doppler = f_{FFT} + 20 \text{ kHz}$$

This approach has several advantages:

- It removes the need for an explicit offset subtraction term.
- It avoids ambiguity regarding whether a frequency shift has already been applied.
- It reduces the risk of double-counting or omitting offsets.

Expected Impact on Bias

By eliminating the explicit f_{dc_offset} correction term, the revised configuration:

- reduces the number of parameters that must be kept consistent across the signal chain
- minimizes the possibility of bookkeeping errors
- ensures that any constant offset observed in the data is more directly attributable to:
 - receiver frequency reference error, or

- nominal carrier uncertainty

As a result, the large bias observed in the current dataset (≈ 2935 Hz) is less likely to arise from software misinterpretation of offsets in future observations.

Residual Bias Considerations

Even with the improved configuration, a residual bias may still be present due to:

- imperfect locking of the SDR to the external 10 MHz reference
- small discrepancies between the assumed and actual spacecraft carrier frequency

However, these effects are expected to be:

- smaller in magnitude
- more stable
- and easier to interpret

compared to biases introduced by offset-handling inconsistencies.

Summary

The revised Doppler extraction method simplifies the signal processing chain and removes a potential source of systematic error. By avoiding explicit offset compensation terms, it improves the robustness of the measurement and increases confidence that any remaining bias reflects true hardware or reference effects rather than software bookkeeping artifacts.

Receiving the Test Beacon

The figures below show a snapshot of the primary and backup SDR receivers while connected to the 60' dish antenna while receiving a test beacon signal. The beacon frequency is sensitive to temperature and so produces a pseudo-Doppler effect that is useful in receiver comparisons and software development.

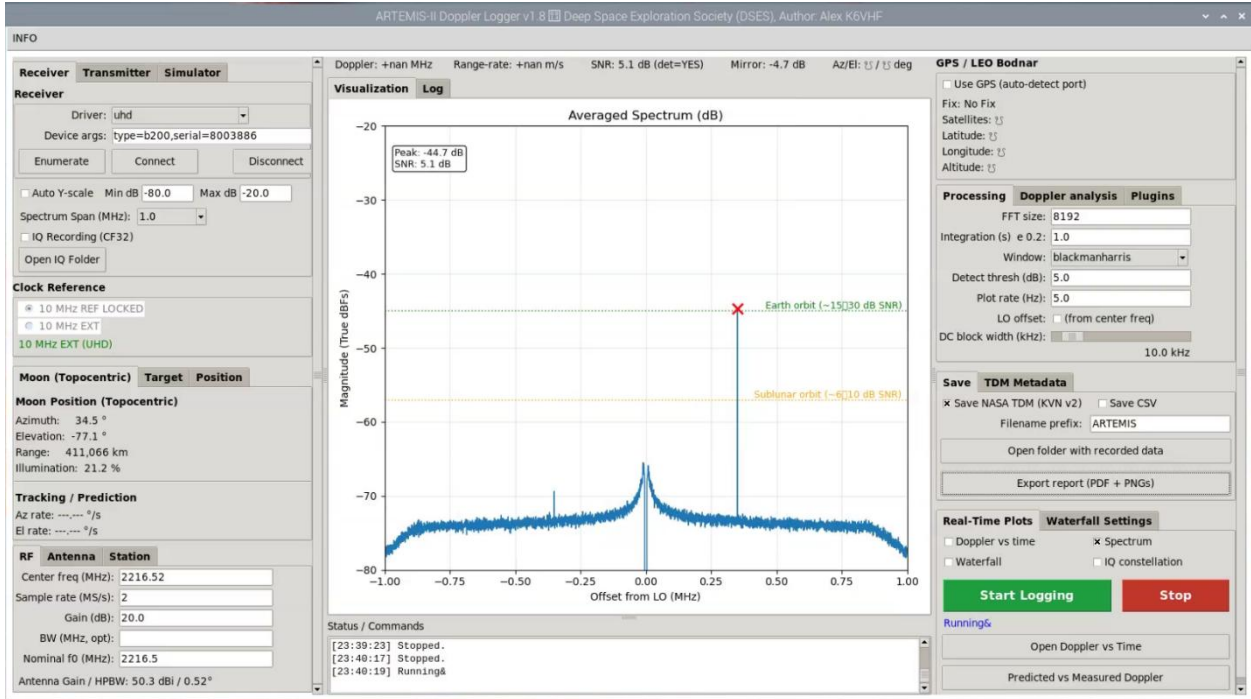
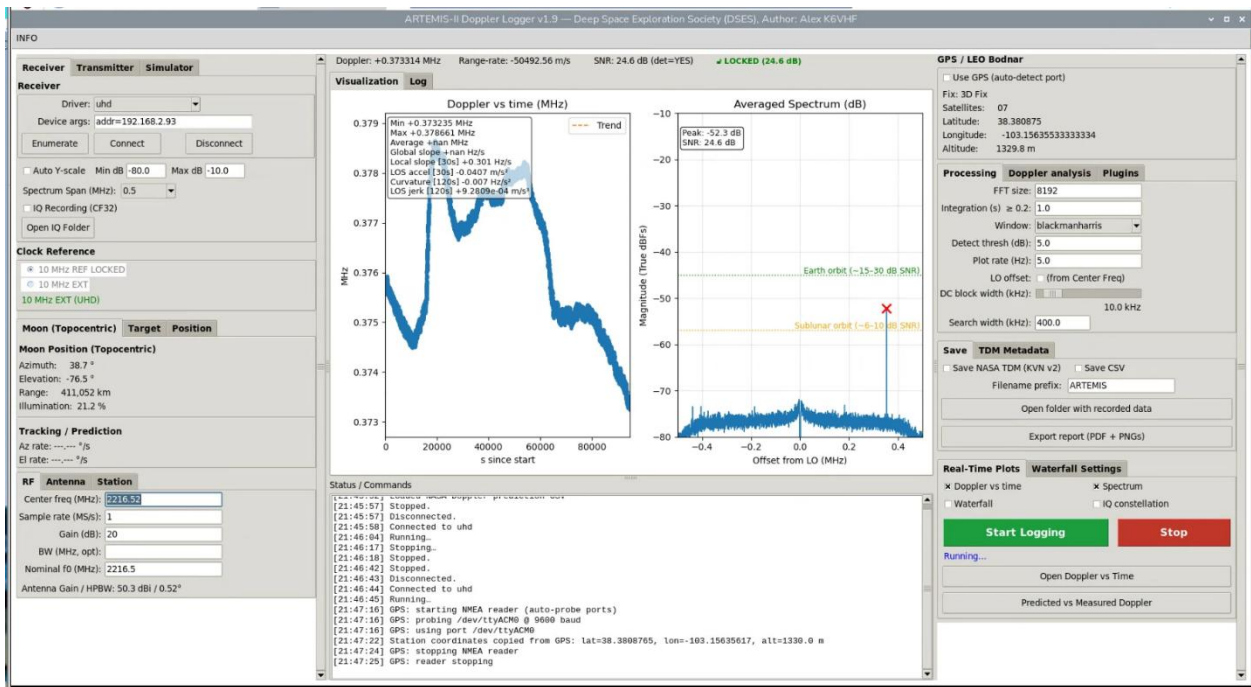

Additional Recording Sessions

Data collected 4/7/2026 by the Primary System

Data collected 4/7/2026 by the primary system showing DSES raw data compared to the JPL Horizons data.

Few things obvious here.

- frequency drift was identified 20.4mHz/sec
- strong phase fluctuations

Other than that, we are on the right slope for Doppler.

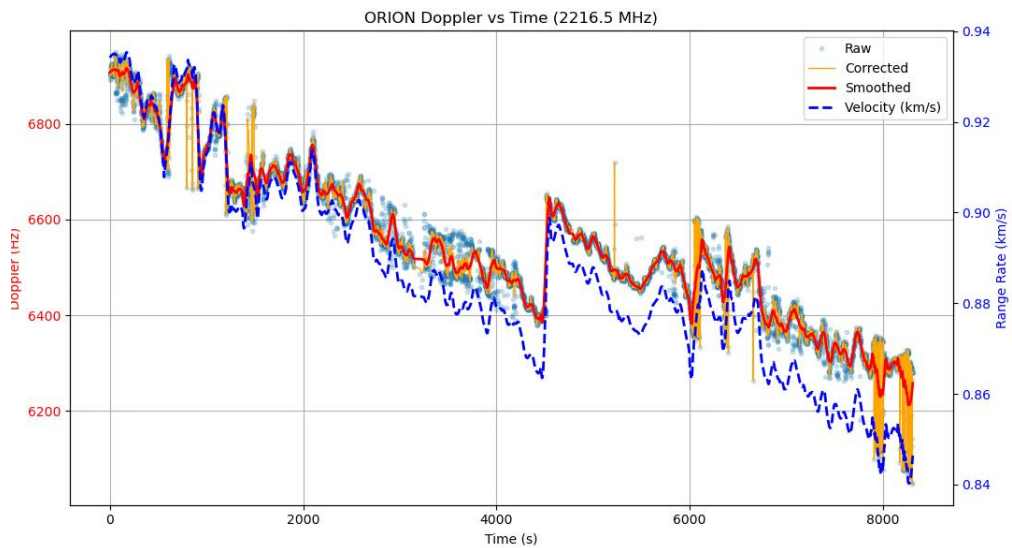
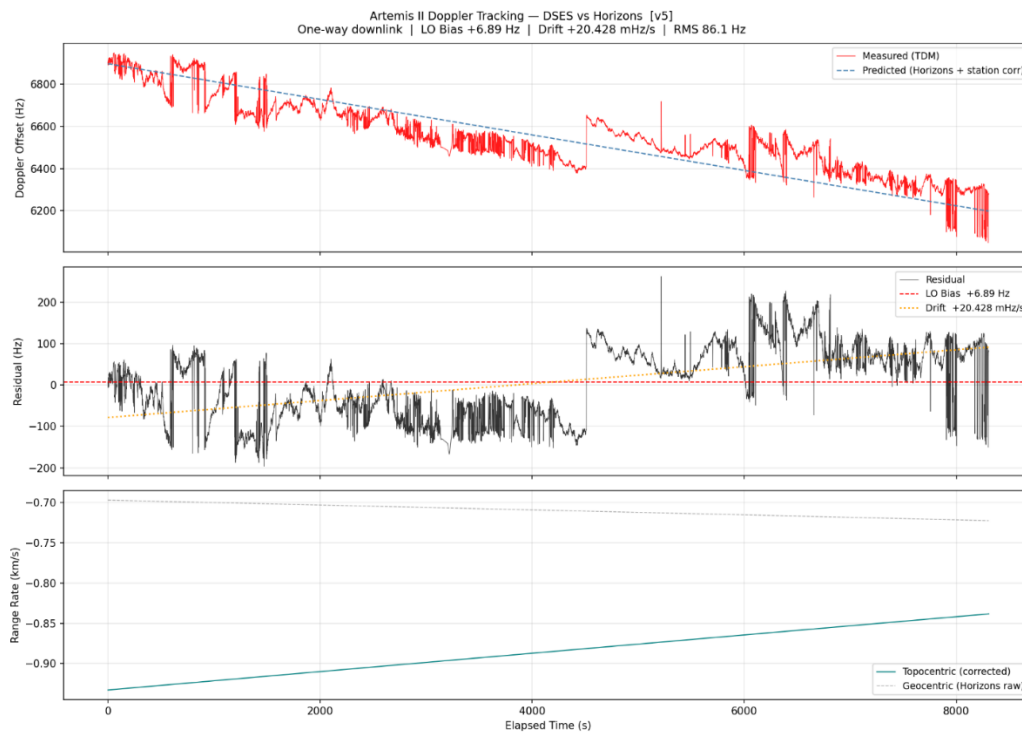

Data collected 4/8/2026 by the primary system:

Out of entire night we only detected two clear ORION transmissions.

First one:

START_TIME = 2026-04-09T06:39:23.990Z - AOS at Haswell

STOP_TIME = 2026-04-09T08:49:02.530Z - signal disappeared

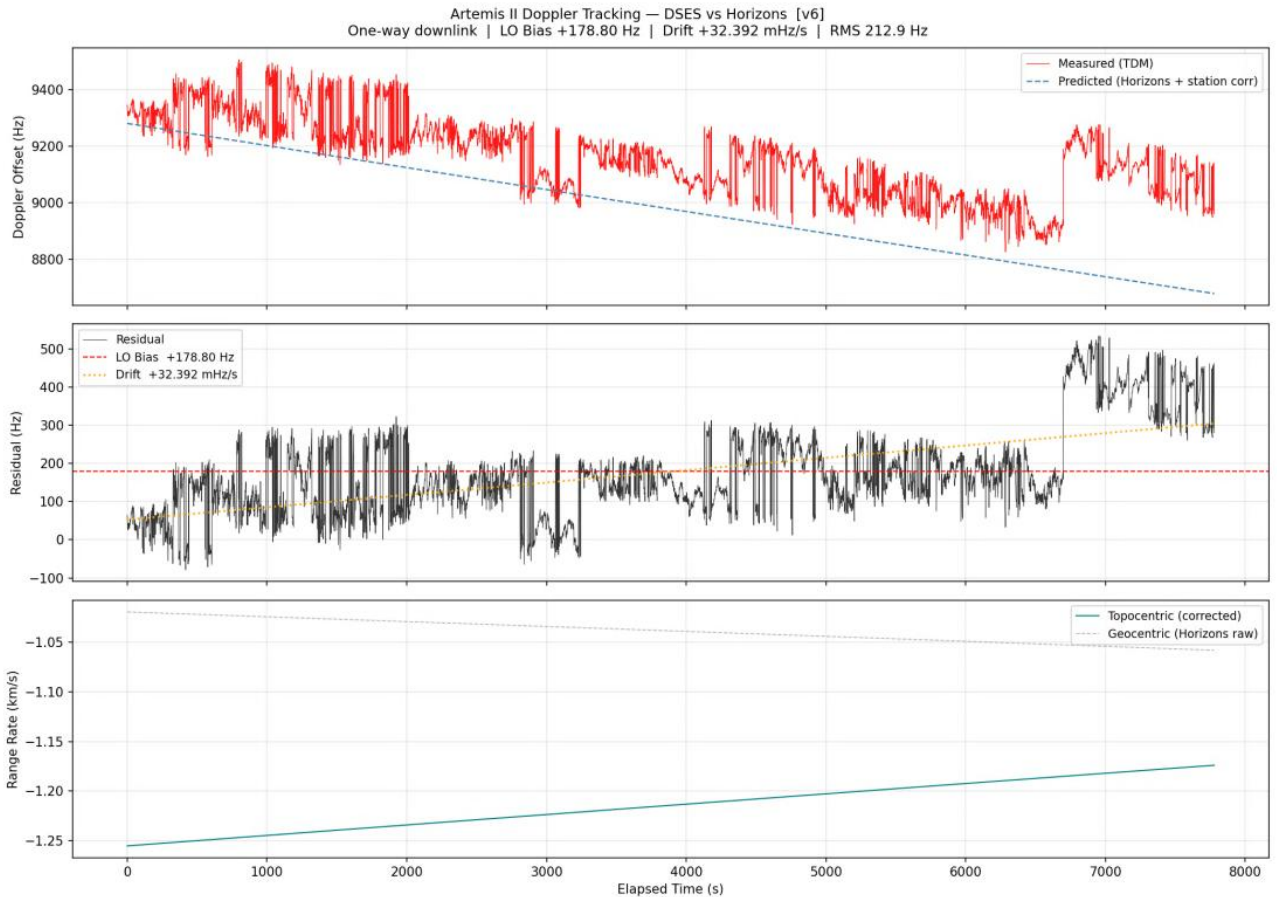

Results

The primary goal of each of the 34 volunteer ground stations was to track the entire Artemis-II mission whenever in view and upload the resulting TDM files to the NASA data collection site for later postprocessing. DSES will only a few valid TDM files to send to NASA because of formatting and scheduling issues, so the primary goal was not met.

Although the primary objective of continuous tracking and submission of TDM files to NASA was not achieved the campaign successfully demonstrated:

- Verified reception of Orion spacecraft signals
- High-fidelity Doppler tracking with strong agreement to predictive models
- Identification and quantification of system-level biases
- Validation of SDR-based deep-space tracking capability

Equally important, the campaign exposed critical system limitations and operational gaps, providing a clear roadmap for improvement. These lessons significantly enhance DSES readiness for future coordinated tracking efforts.

The DSES mission, as stated on our web site, is: “DSES is a not-for-profit organization and a recognized Colorado charity whose primary purposes are research and education. We exist

to foster the exploration and understanding of space by encouraging students, society members, and the general public to participate in that exploration. We facilitate experiments designed to expand our knowledge of space, and to execute ground-based missions designed to support those experiments.” In this regard I believe we have succeeded quite well. Feedback from members is generally positive in this respect and is a primary motivator for most members to continue their involvement with DSES and its programs.

Lessons Learned

Antenna Feed Optimization

Proper matching of feed illumination to dish geometry is essential. Future designs should ensure that the -10 dB illumination edge aligns with the reflector boundary to maximize efficiency and minimize spillover.

RF Chain Design

A clearer understanding of the relationship between overall antenna performance (G/T), system noise figure, gain distribution, and SDR dynamic range is required. Future designs should be based on quantitative system modeling rather than heuristic approaches.

The secondary system was plagued by the presence of a phantom signal that apparently overwhelmed the Orion spacecraft data and ruined the last two days of our recording sessions. The cause is under investigation. It may be related to the gain settings on the SDR (a B210 clone). The B210 has a very different front end than the SDR in the primary system. The following guideline didn't seem to work well with our RF path planning.

- **Receive (RX) Gain:**
 - **Range:** 0 to 76 dB.
 - **Dynamic Range:** Use at least **half the available gain** (38 dB+) to maintain a reasonable dynamic range.
 - **Max Input Power:** The absolute maximum input for the B210 is **0 dBm**.

Data Acquisition Strategy

Late-stage changes to recording formats introduced significant risk. Future campaigns should:

- Freeze data formats prior to operations
- Validate compatibility with external requirements (e.g., NASA TDM)
- Conduct end-to-end testing well in advance
- Choosing to record I/Q data, while advantageous in many respects, requires advanced planning on how to manage high bandwidth data and large files effectively.

Software Integration and Testing

Software development is often the weakest link in a project. For example, a critical error in the TDM file formats was not found until the mission was nearly complete. This resulted in DSES lacking much if any data to send NASA as they specifically asked that we not modify the TDM files after the mission. Future efforts should include:

- A clearly understood statement of purpose and requirements

- A change control discipline
- Version control discipline
- Formal code reviews
- Quality control authority

System Architecture

Relocating SDR hardware to the antenna hub did not produce measurable performance benefits and increased operational complexity. Future designs should favor maintainability unless clear advantages are demonstrated.

Teamwork

Most of the DSES's teams came together with remarkable effectiveness and dedication. Where teamwork was strongest the mission processes worked best.

We had the opportunity to cooperate with outside organizations including ORI, Dwingeloo Radio Observatory, Bochum Observatory, and Astropeler Stockert (Stockert Radio Telescope). For a variety of reasons DSES has not pursued these potential partnerships, but we have lost opportunities as a result.

Appendix A: Light-Time Doppler Model Description

The Doppler analysis presented in this work is based on a **one-way light-time corrected geometric model**, augmented with empirical bias and drift estimation to account for instrumental and reference uncertainties.

Measurement Definition

The measured Doppler observable is derived from the SDR processing chain as:

$$f_{meas}(t) = (f_{center} + f_{FFT}(t)) - f_0$$

Where:

- f_{center} is the SDR tuning frequency,
- $f_{FFT}(t)$ is the spectral offset, and
- f_0 is the nominal carrier.

This produces a Doppler estimate in Hz relative to the assumed nominal carrier.

One-Way Light-Time Geometry

The model accounts for the finite propagation time of the signal between spacecraft and ground station.

The receive time t_{rx} and transmit time t_{tx} are related by:

$$t_{tx} = t_{rx} - \frac{R(t_{tx})}{c}$$

where:

- $R(t)$ is the geometric range between spacecraft and station

- c is the speed of light

This equation is solved iteratively to obtain the correct transmit epoch.

State Vectors

Spacecraft position and velocity are obtained from JPL Horizons in an Earth-centered inertial (ECI) frame:

$$r_{sc}(t), v_{sc}(t)$$

The ground station state is computed from geodetic coordinates using Earth rotation:

$$r_{st}(t), v_{st}(t)$$

Line-of-Sight Kinematics

The instantaneous line-of-sight unit vector is:

$$\hat{\rho} = \frac{r_{sc}(t_{tx}) - r_{st}(t_{rx})}{\|r_{sc}(t_{tx}) - r_{st}(t_{rx})\|}$$

The relative radial velocity is:

$$\dot{R}(t) = (v_{sc}(t_{tx}) - v_{st}(t_{rx})) \cdot \hat{\rho}(t)$$

Predicted Doppler

The predicted one-way Doppler shift is given by:

$$f_{pred}(t) = -f_0 \frac{\dot{R}(t)}{c}$$

where the negative sign follows the convention that positive radial velocity (receding) produces a negative frequency shift.

Time Averaging

To account for finite integration time in the receiver, the predicted Doppler is optionally averaged over a time window Δt :

$$\bar{f}_{pred}(t) = \left(\frac{1}{\Delta t}\right) \int_{t-\Delta t/2}^{t+\Delta t/2} f_{pred}(\tau) d\tau$$

This models the effective measurement bandwidth and spectral estimation process.

Bias and Drift Model

Residual differences between measurement and model are represented by a linear correction:

$$f_{fit}(t) = f_{pred}(t) + b + dt$$

where:

- b is a constant frequency bias
- d is a linear frequency drift term

These parameters are estimated via least-squares fitting.

Residuals and Performance

The post-fit residual is:

$$\varepsilon(t) = f_{meas}(t) - f_{fit}(t)$$

The model performance is quantified using the root-mean-square (RMS) residual:

$$\sigma_f = \sqrt{\frac{1}{N} \sum_{i=1}^N \varepsilon_i^2}$$

The model performance is quantified using the root-mean-square (RMS) residual:

$$\sigma_v = \frac{c}{f_0} \sigma_f$$

Implied Carrier Frequency

The fitted bias term provides an estimate of the effective carrier frequency:

$$f_{0,eff} = f_0 - b$$

This value reflects the combined effects of:

- receiver frequency reference error
- nominal carrier uncertainty
- constant offsets in the measurement definition

Summary

The light-time carrier model incorporates:

- full geometric spacecraft motion from JPL Horizons
- Earth rotation and station motion
- one-way signal propagation delay
- optional measurement time averaging

- empirical bias and drift correction

This framework enables high-fidelity comparison between measured and predicted Doppler and supports quantitative assessment of system performance.

Appendix B: 10MHz Reference Calibration Run

The attached slides represent the calibration run for the period including the Artemis mission. The first slide shows the drift of the HP5065A Rubidium oscillator over a period that includes the Artimus mission. It shows that the reference 10MHz signal that was used to drive our SDR receivers had a frequency error of approximately 1.5 parts in 10^{-12} as compared to GPS. This data shows that the precision 10MHz reference is more than good enough for the requirements of this mission and is unlikely to be responsible for any data irregularities.

CNS Clock "A" (M12+) vs. HP5065A (2816A) Software Drift Chart

Data logged by Tac32Plus. Analyzed by Python + Pandas on 11-Apr-2026, © 2026 CNS Systems, Inc.

Averaging period is 300 seconds, Software corrected 1PPS with

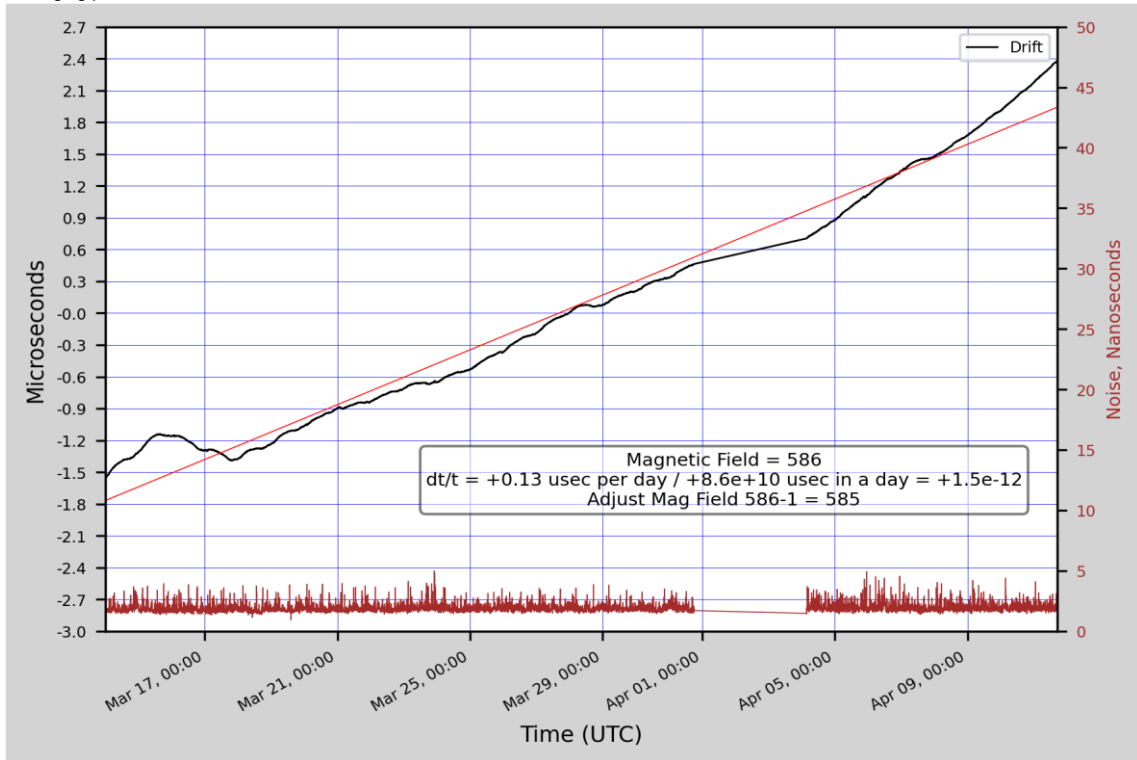

Below is data with the drift removed and the raw and quantized corrected GPS pulse-per-second (PPS) data.

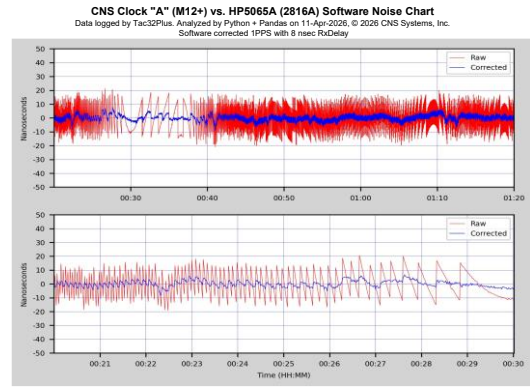
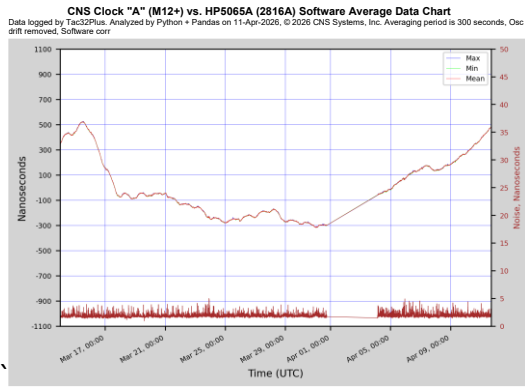

Appendix C: Precision NTP Source

The DSES precision NTP time source is a part of the new Precision Time and Frequency rack. It is driven directly by a GPS receiver that had been calibrated at USNO and can deliver about 100 microsecond accuracy to any client on the DSES local area network (LAN).

The ChroGPS dashboard for the “DSES Time & Frequency” node provides a comprehensive real-time view of system timing performance and GPS receiver status. The system is shown in a **GPS LOCKED** condition, confirming that the local timebase is actively disciplined by a calibrated GPS reference.

The **System Tracking** panel indicates excellent synchronization health at **100%**, with a reported timing offset on the order of tens of nanoseconds. The node is operating as a **Stratum-1 NTP server**, using a direct **PPS (Pulse Per Second)** reference from the GPS receiver. Measured performance metrics include negligible last offset, very low RMS timing error ($\sim 10^{-7}$ seconds), and stable frequency control with minimal residual drift.

The **server statistics** confirm sustained operation, with millions of NTP packets processed and zero packet loss, indicating reliable time distribution across the DSES local network.

SYSTEM TRACKING

LOCAL 12:41:31 | UTC 18:41:31Z

SYNC HEALTH

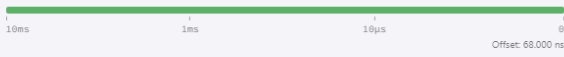

SYNC STATUS

Reference ID	50505300 (PPS)	Stratum	1
Ref time (UTC)	Tue Apr 14 18:41:23 2026	System time	0.00000068 seconds slow of NTP time
Last offset	-0.00000059 seconds	RMS offset	0.00000032 seconds
Frequency	9.510 ppm fast	Residual freq	-0.000 ppm
Skew	0.004 ppm	Root delay	0.00000001 seconds
Root dispersion	0.000003152 seconds	Update interval	2.0 seconds
Leap status	Normal	Clock Steps (24h)	0
Last Step	Never	Freq Limit	0% of 500000 ppm (default)
Chrony Uptime	17d 17h 55m		

SERVER STATISTICS

NTP packets received	3410198	NTP packets dropped	0
Command packets received	417876	Command packets dropped	0
Client log records dropped	0	NTS-KE connections accepted	0
NTS-KE connections dropped	0	Authenticated NTP packets	0
Interleaved NTP packets	3406172	NTP timestamps held	8192
NTP timestamp span	4106	NTP daemon RX timestamps	0
NTP daemon TX timestamps	4026	NTP kernel RX timestamps	3410198
NTP kernel TX timestamps	3406172	NTP hardware RX timestamps	0
NTP hardware TX timestamps	0		

NTP CONFIGURATION

Make Step	1s - first 3 updates	Max Drift	500000 ppm (default)
Refclock Poll	2s (2^1)	Ref Precision	0.0000001s

NODE VITALS

SATELLITE SKYVIEW

3D FIX (TIME)

SIGNAL INTEGRITY

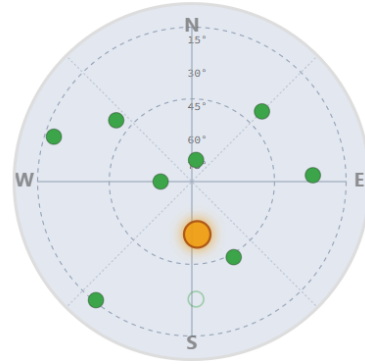
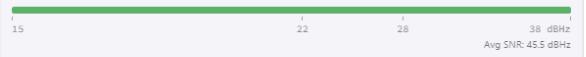

• ACTIVE FIX 8 ○ VISIBLE 1 ● TOTAL 9

INDIVIDUAL SIGNAL LEVELS

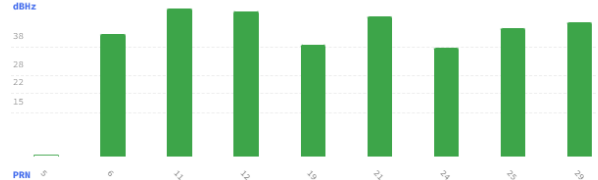

CONSTELLATION BREAKDOWN

GPS 8/9

GPS FIX INFO

The **Satellite Skyview** panel shows the spatial distribution of GPS satellites currently in view, with **8 satellites contributing to the active timing solution**. Signal integrity is reported at **100%**, and the average signal-to-noise ratio (~47 dB-Hz) indicates strong, high-quality reception. The polar sky plot demonstrates good geometric diversity, which is essential for maintaining timing accuracy and robustness.

The **individual signal level chart** further confirms consistent satellite signal strength across the tracked constellation, supporting stable GPS lock and precise time transfer.

Overall, this display demonstrates that the DSES precision timing system is operating nominally, delivering high-stability, GPS-disciplined time with performance consistent with the expected ~100 microsecond (or better) network distribution accuracy described for the DSES NTP service.

This ChroGPS view presents the **Chrony source selection status** alongside detailed **GPS satellite signal data**, providing insight into both time reference hierarchy and signal quality.

The **Chrony Sources** panel shows that the system is primarily disciplined by the **GPS receiver** and, more importantly, the **PPS (Pulse Per Second) reference**, which provides the highest precision. The PPS source exhibits a timing offset on the order of **hundreds of nanoseconds**, confirming that it is the dominant reference used to achieve stratum-1 performance.

Several external NTP servers, including **USNO hosts (e.g., tick.usno.navy.mil and tock.usno.navy.mil)**, are also configured as secondary references. These sources show offsets in the **millisecond range**, which is expected due to network latency, and serve as validation and backup rather than primary timing inputs.

The **polling intervals and reach values (100%)** indicate stable and continuous communication with all configured sources, with no loss of synchronization.

The **Satellite SNR Data** panel lists individual GPS satellites contributing to the solution, including their **PRN identifiers, elevation and azimuth angles, and signal-to-noise ratios (SNR)**. A total of **8 satellites are active out of 9 visible**, all operating on the **L1 C/A band**.

Reported SNR values (typically **~40–52 dB-Hz**) indicate strong, reliable signal reception across the constellation. The distribution of satellites across different azimuth and elevation angles provides good geometric diversity, which enhances timing accuracy and robustness.

Overall, this display confirms that the DSES timing system is correctly prioritizing the **high-precision PPS reference**, while maintaining healthy satellite tracking and redundant network time sources, ensuring both **accuracy and resilience** in the NTP service.

VIEWS: All Views Tracking Sources Graphs Cycle Views

CHRONY SOURCES

S	SOURCE NAME	STRAT	POLL	REACH	LAST	OFFSET / [ACTUAL]
#?	GPS	0	2	100%	3	+158ms [+158ms] ...
#*	PPS	0	1	100%	1	-495ns [-588ns] ...
A-	192.5.41.40	1	11	100%	779	+1386us [+1390us] ...
A-	192.5.41.41	1	10	100%	45	+1221us [+1221us] ...
A-	tock.usnogps.navy.mil	1	11	100%	999	+14ms [+14ms] +/-
A-	tock.usnogps.navy.mil	1	11	100%	31m	+14ms [+14ms] +/-

SATELLITE SNR DATA

8 ACTIVE / 9 TOTAL

GPS: 8

PRN	EL	AZ	SNR	BAND	STAT
5	26°	178°	0 dBHz	L1 C/A	VIEW
6	35°	46°	43 dBHz	L1 C/A	ACTIVE
11	78°	12°	52 dBHz	L1 C/A	ACTIVE
12	73°	269°	50 dBHz	L1 C/A	ACTIVE
19	24°	87°	39 dBHz	L1 C/A	ACTIVE
21	43°	150°	49 dBHz	L1 C/A	ACTIVE
24	7°	219°	40 dBHz	L1 C/A	ACTIVE
25	36°	309°	45 dBHz	L1 C/A	ACTIVE
29	11°	289°	42 dBHz	L1 C/A	ACTIVE

This ChroGPS **Cycle View** presents system performance over a defined observation interval, showing the relationship between **timing offset** (green trace) and **frequency deviation** (blue trace) as the NTP server's GPS-disciplined oscillator progresses through acquisition and steady-state operation.

The initial portion of the plot captures a **repeatable acquisition transient**, where the timing offset briefly reaches millisecond-level excursions before rapidly converging toward zero. This behavior reflects the control loop's response when aligning the local oscillator with the GPS PPS reference.

Following acquisition, the system enters a stable regime in which the **timing offset remains effectively zero** while the **frequency correction settles into a narrow operating band (~9.37–9.79 ppm)**. The small, continuous adjustments in frequency demonstrate normal disciplining activity as the system compensates for oscillator drift and environmental influences.

The Cycle View is particularly useful for verifying **consistency and repeatability** of the synchronization process. The absence of sustained offset excursions and the smooth, bounded frequency behavior indicate a well-tuned control loop with stable long-term performance.

Overall, this figure confirms that the DSES timing system not only achieves rapid synchronization but does so in a **predictable and repeatable manner**, reinforcing confidence in its use as a reliable, GPS-disciplined **stratum-1 NTP reference**.



There are a variety of other graphical views that can be useful in evaluating the NTP server's performance.

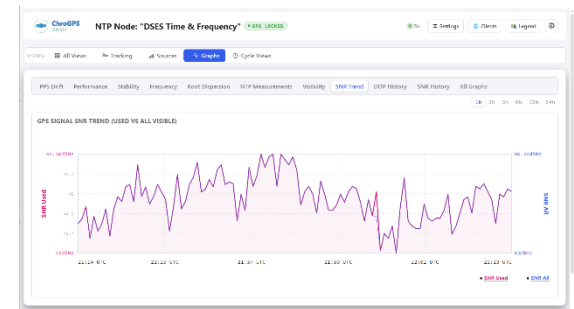
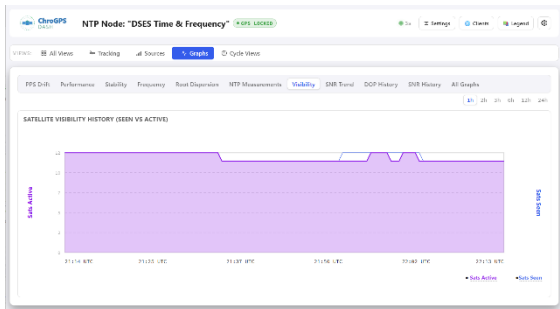
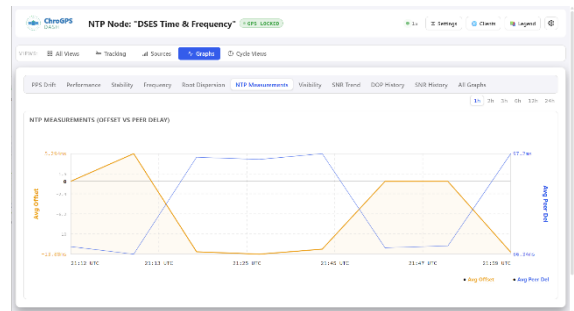
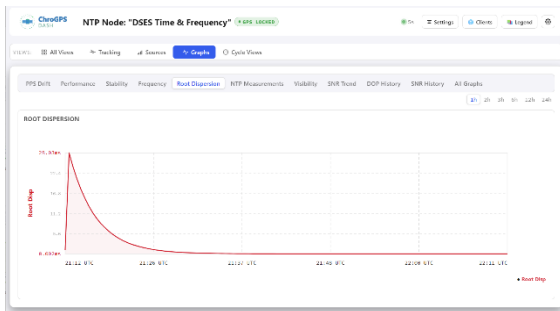
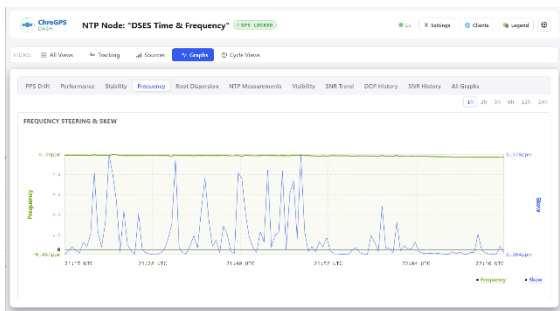
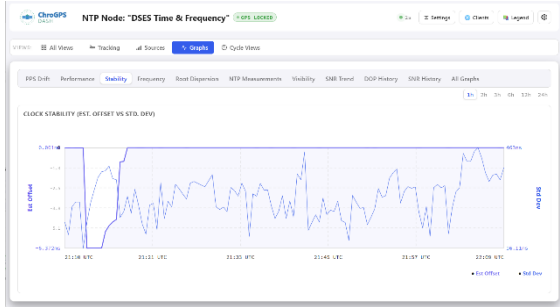
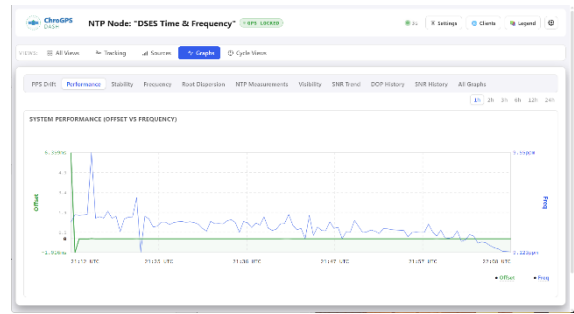
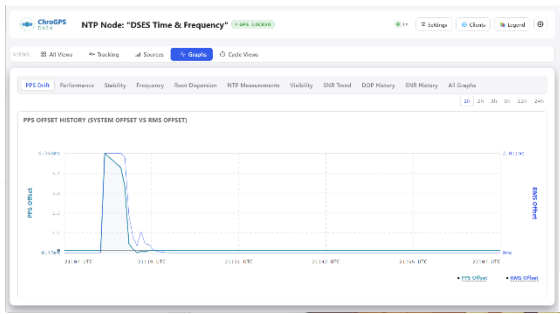

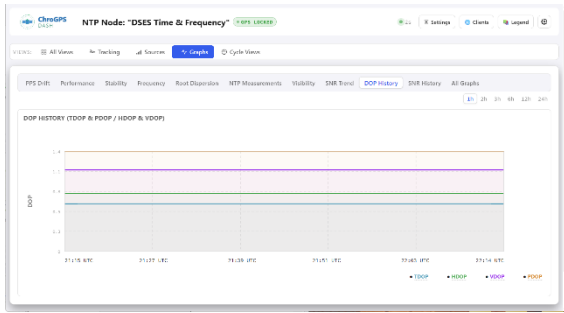

Repeatable Multi-night Zenith H I Drift Scans with a 2.1-m Amateur Radio Telescope in Glendora, California

Pablo Lewin

Maury Lewin Astronomical Observatory, Glendora, California, USA

Contact: pablotwa1@gmail.com

Abstract

A seven-run observing campaign of the Galactic 21 cm neutral-hydrogen line was carried out from Glendora, California with a 2.1 m zenith-pointing amateur radio telescope near 1420.4058 MHz. Six runs from 18 March through 5 April 2026 were intercompared as a repeatability set, and a seventh 1,000-spectrum run on 10–11 April 2026 was analyzed as a detailed case study and synchronized with a contemporaneous sky timelapse. Because the telescope remained fixed at zenith, Earth’s rotation carried a constant-declination sky strip through the beam. Across the six directly comparable runs, pairwise Pearson correlations of local sidereal time binned H I line-strength profiles ranged from 0.898 to 0.987, with the two strongest windows recurring near LST ≈ 5.5 h and ≈ 20.5 h. The April 10–11 case-study run contained 1,000 spectra with 451,000 accumulations per saved spectrum, a median cadence of 97 s, an estimated beam FWHM of 6.9° , and strong topocentric line peaks near $+31$ km s^{-1} in the Galactic anticenter-side window and -28 km s^{-1} in the Cygnus-side window. Empirically, reducing the accumulation count from 901,000 to 451,000 preserved the main sky signal but lowered single-spectrum robustness, while adjacent-spectrum pairing recovered only part of the ideal square-root-of-two signal-to-noise gain. The campaign shows that a small amateur dish can reproducibly detect large-scale Milky Way H I structure in zenith drift mode and outlines the calibration steps needed for stronger external validation against surveys such as LAB and HI4PI.

Introduction

Observations of the Galactic H I 21 cm line are among the most accessible and scientifically valuable projects for amateur radio astronomers. Even small dishes can detect large-scale neutral-hydrogen structure in the Milky Way if frequency stability, integration time, and baseline handling are adequate [1–3]. Large professional surveys such as LAB and HI4PI provide a reference context for what an amateur system should measure once the spectra are placed on a common velocity scale and smoothed to the appropriate beam [4, 5].

The observing campaign described here began as a set of exploratory zenith drift scans. The telescope was left pointed straight up, so the sky itself performed the scan as Earth rotated. This approach has two important advantages for a small observatory. First, it is mechanically

simple and highly repeatable. Second, because the elevation is fixed, the atmospheric path length remains nearly constant, so changes in the measured H I signal are dominated by changing sky position rather than by changing air mass.

The goals of this article are to document the instrument and observing mode, test repeatability across multiple runs, compare lower- and higher-accumulation settings empirically, and present one detailed case-study run with dynamic-spectrum and sky-geometry products suitable for the SARA community.

Instrumentation and observing campaign

The observations were made from Glendora, California, USA, at approximately 34.14° N and 117.87° W. The system consisted of a 2.1 m dish and an H-line receiver chain described by the observer as using a Discovery Dish LNA. This article does not rely on a manufacturer noise-figure specification for that LNA because no independently verified hardware characterization was available during the reductions. Instead, system performance is inferred empirically from the spectra themselves.

At the H I rest wavelength, $\lambda \approx 0.211$ m, the expected half-power beam width is approximately

$$\theta_{3\text{dB}} \approx 1.2 \lambda / D . \quad (1)$$

For $D = 2.1$ m, Equation (1) gives a beam FWHM of about 6.9°, consistent with the value used throughout the analysis.

The ideal thermal-noise behavior is described by the radiometer equation,

$$\Delta T \approx T_{\text{sys}} / \sqrt{(\Delta\nu \tau)} . \quad (2)$$

As shown later, the empirical behavior of the 451k and 901k modes departs somewhat from ideal square-root scaling, indicating a practical systematic floor.

Run	Saved spectra	Accumulations	Median cadence (s)	Notes
2026-03-18 901k	1000	901000	193	901k reference run
2026-03-23 901k	323	901000	193	901k reference run
2026-03-29 901k	1000	901000	193	901k reference run
2026-04-02 451k	958	451000	97	451k run
2026-04-04 451k	1000	451000	97	451k run
2026-04-05 451k	1000	451000	97	451k run
2026-04-10/11 451k case study	1000	451000	97	Detailed single-run analysis + synced timelapse

Table 1: Summary of the observing runs used in this article.

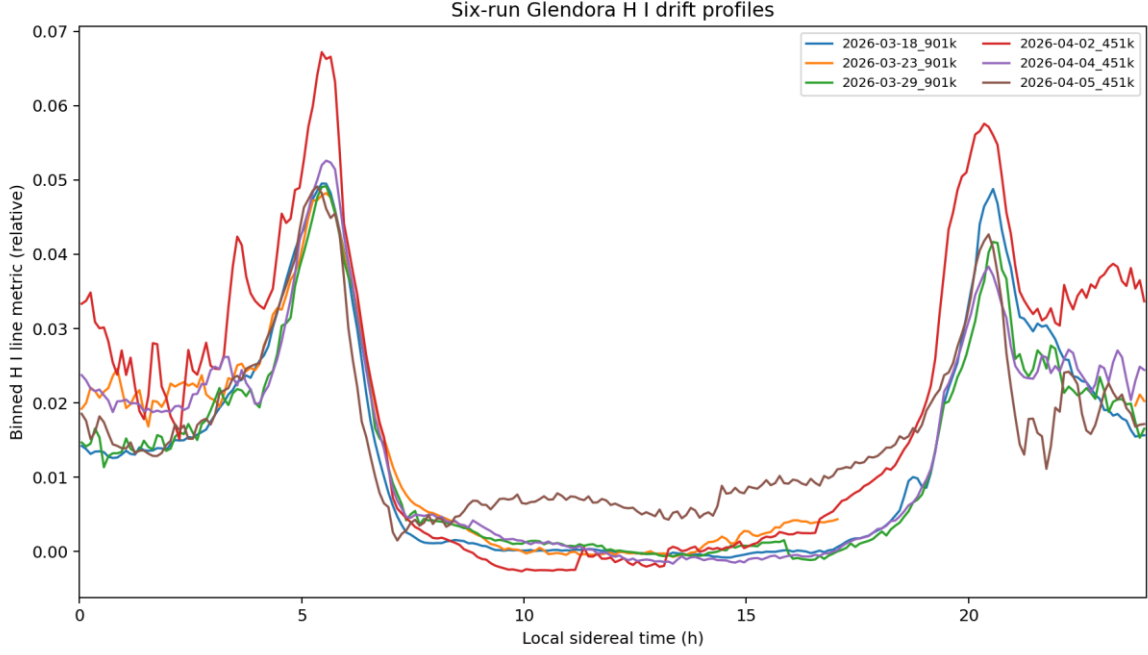

Figure 1: Six-run comparison of LST-binned H I-strength profiles from 18 March through 5 April 2026.

Data reduction

Each saved file contained a 512-channel spectrum. The 901k runs had a typical cadence of about 193 s per saved spectrum, while the 451k runs had a cadence of about 97 s per saved spectrum. The reduction steps were intentionally conservative: timestamps were parsed from the saved spectra, spectra were sorted into time order, a line-strength metric was formed over the H I window, and drift profiles were folded into sidereal time for repeatability comparisons.

Topocentric radio velocities were computed relative to the rest frequency $\nu_0 = 1420.40575$ MHz using

$$\nu_{\text{radio}} \approx c (\nu_0 - \nu) / \nu_0 . \quad (3)$$

This article reports topocentric velocities unless otherwise stated. Approximate LSRK products were generated elsewhere in the broader analysis workflow, but the present article emphasizes reproducible topocentric behavior and sky geometry. To suppress slowly varying instrumental structure, representative spectra were also shown after subtraction of a quiet-sky reference. No definitive conversion to Kelvin or Jansky was attempted from first principles.

Because all observations were obtained at zenith, the atmospheric path length was close to one air mass throughout each run. Atmospheric emission and attenuation therefore acted mainly as a nearly constant system contribution within a run rather than as a strongly varying extinction term.

Results: campaign repeatability

The central observational result is that the drift profiles repeat from run to run. The six-run local sidereal time comparison showed that the same two broad H I maxima recur consistently near LST ≈ 5.5 h and LST ≈ 20.5 h. These correspond to two major Galactic windows sampled by the Glendora zenith track.

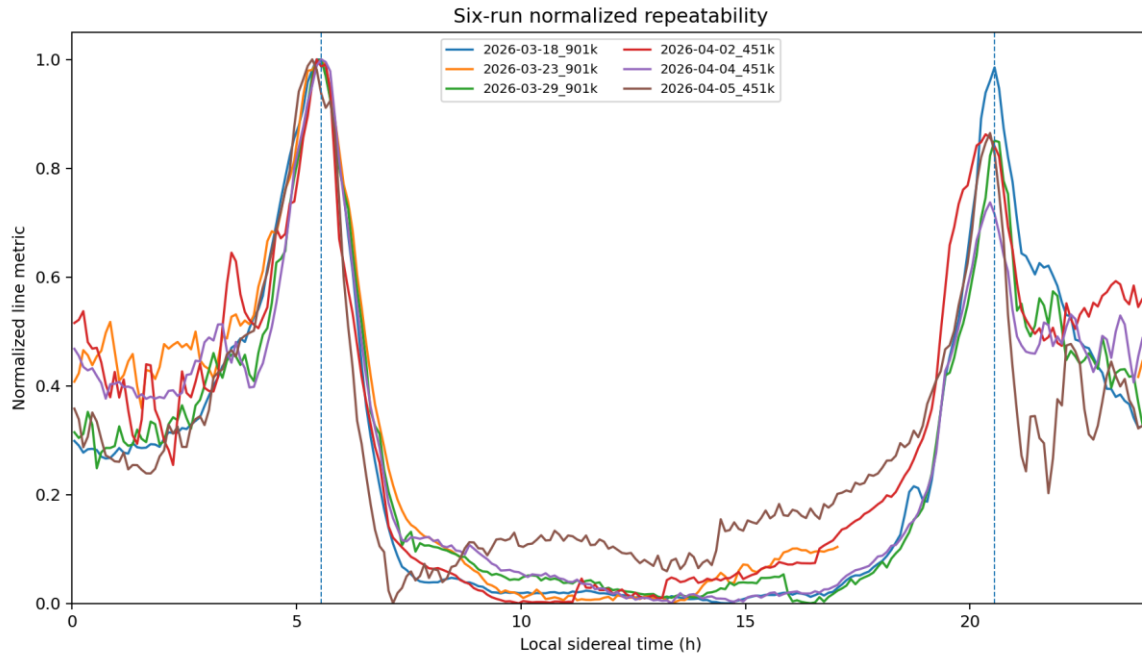

Figure 2: Normalized six-run H I-strength profiles. The main sky features remain at the same sidereal positions.

To quantify repeatability, Pearson correlations were computed over overlapping sidereal bins. Across the six directly comparable runs, the correlations ranged from 0.898 to 0.987. Even the lowest-correlation pair still preserved the same two dominant H I windows.

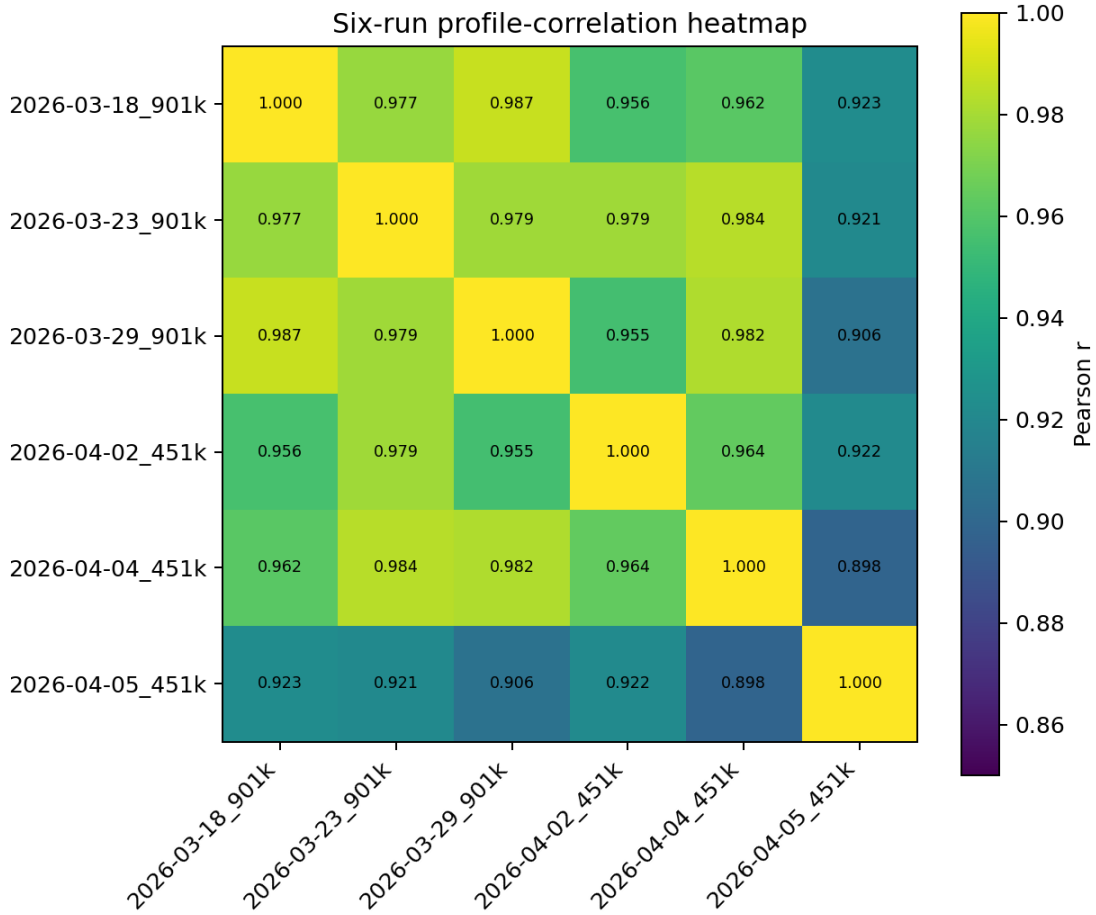

Figure 3: Pairwise Pearson correlations of LST-binned profiles across the six-run campaign.

Pair	Pearson r
2026-03-18_901k vs 2026-03-29_901k	0.987
2026-03-23_901k vs 2026-04-04_451k	0.984
2026-03-29_901k vs 2026-04-04_451k	0.982
2026-03-23_901k vs 2026-03-29_901k	0.979
2026-03-23_901k vs 2026-04-02_451k	0.979
2026-03-18_901k vs 2026-03-23_901k	0.977

Table 2: Representative high-correlation profile pairs from the six-run campaign.

451k versus 901k accumulations

A practical observing question is how much saved-spectrum accumulation can be reduced before H I detections become fragile. The campaign included both 901,000-accumulation and 451,000-accumulation modes. The 451k mode preserved the same sky-driven profile shape, but the individual saved spectra were less robust. In the strongest Galactic windows, pairing adjacent 451k spectra to form an effective approximately 902k product improved peak SNR by only about 1.13–1.19 \times , rather than the ideal $\sqrt{2}$ expected for purely thermal noise.

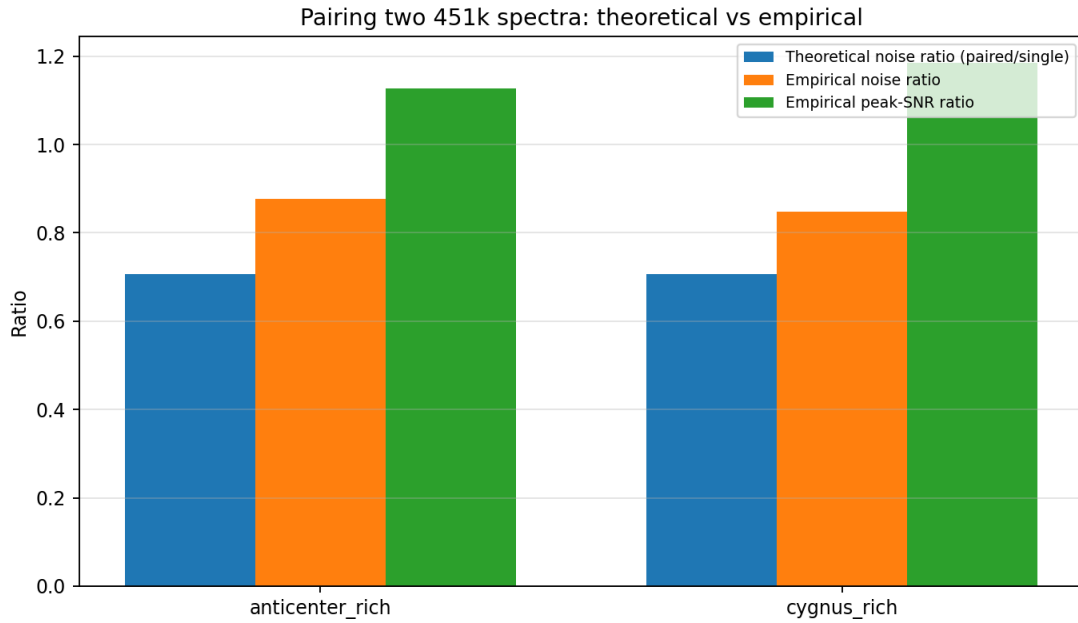

Figure 4: Theoretical versus empirical gain when adjacent 451k spectra are paired to mimic approximately 902k integration.

Detailed case study: 10–11 April 2026

The 10–11 April 2026 run is especially useful because it contains 1,000 spectra, spans about 28.4 hours, and includes overlap in sidereal time between successive dates. Key parameters for this run were: 1,000 saved spectra, 451,000 accumulations per spectrum, median cadence 97 s, frequency coverage 1418.655 to 1421.050 MHz, and a theoretical beam FWHM of 6.9°.

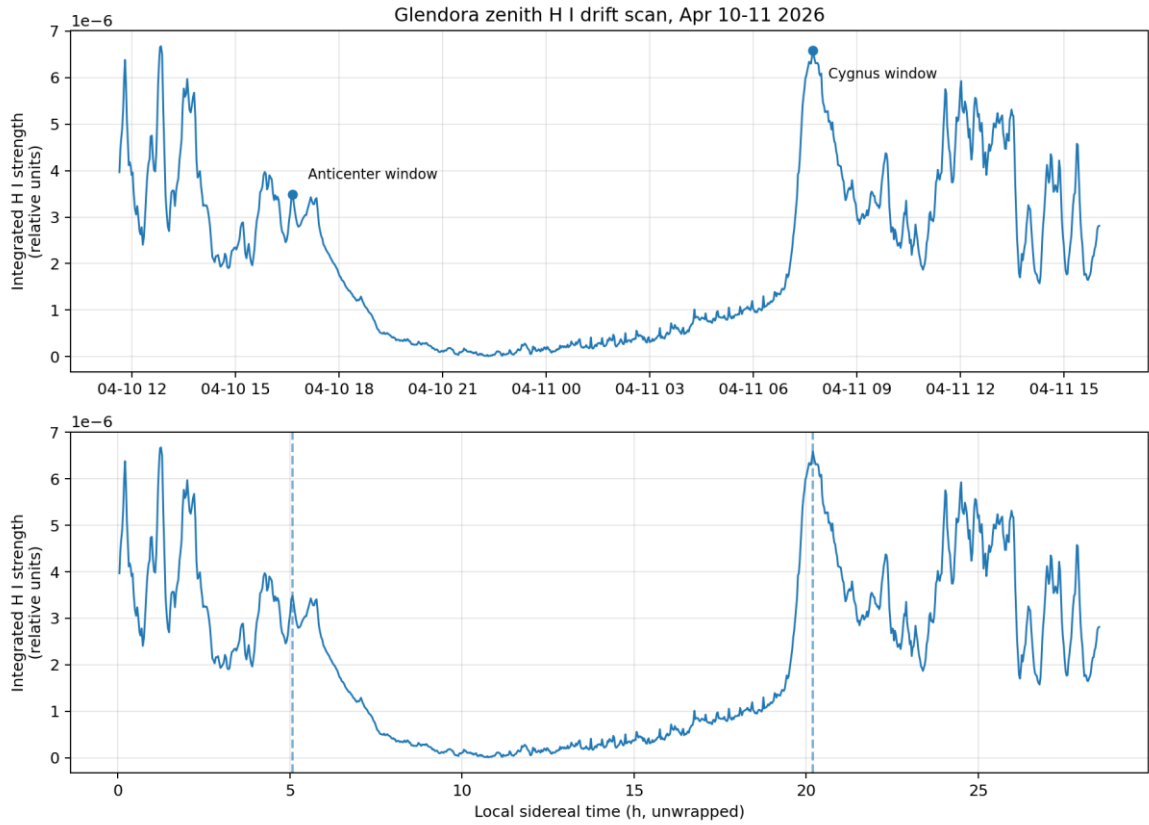

Figure 5: Integrated H I strength versus time and sidereal time for the 10–11 April 2026 case-study run.

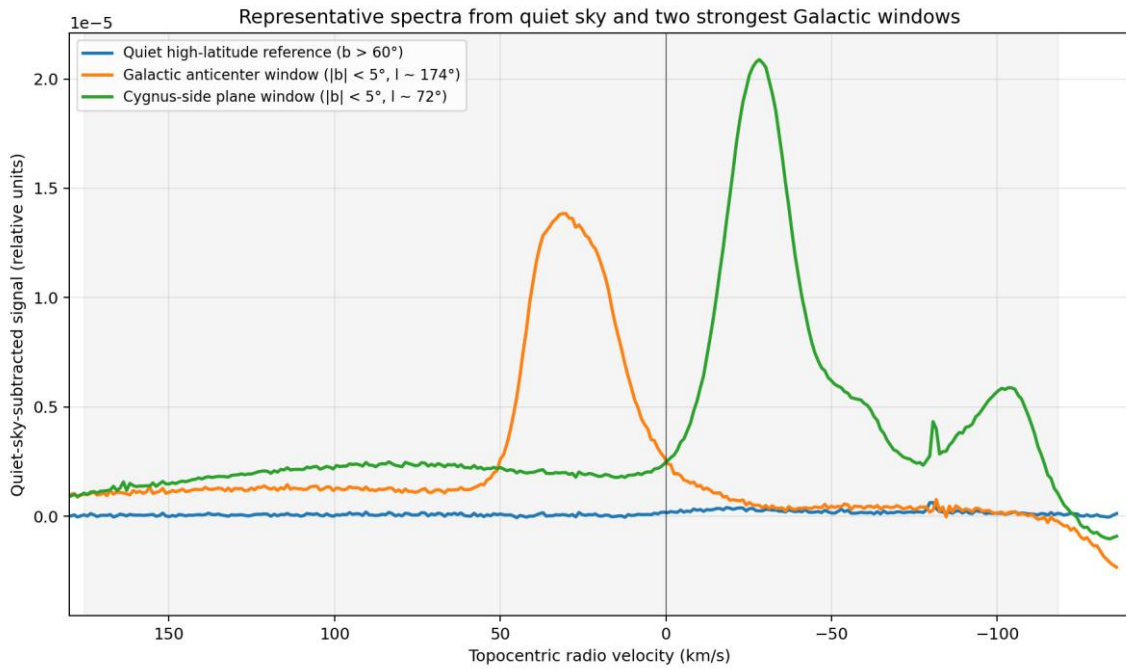

Figure 6: Quiet-sky-subtracted representative spectra from the 10–11 April 2026 run.

The strongest sample in the Galactic anticenter-side window occurred at 2026-04-10 16:39:07 local time, near $l \approx 170.8^\circ$, $b \approx -4.3^\circ$, with a topocentric peak velocity of about $+31.2 \text{ km s}^{-1}$. The strongest sample in the Cygnus-side window occurred at 2026-04-11 07:43:42 local time, near $l \approx 71.9^\circ$, $b \approx 0.2^\circ$, with a topocentric peak velocity of about -28.2 km s^{-1} .

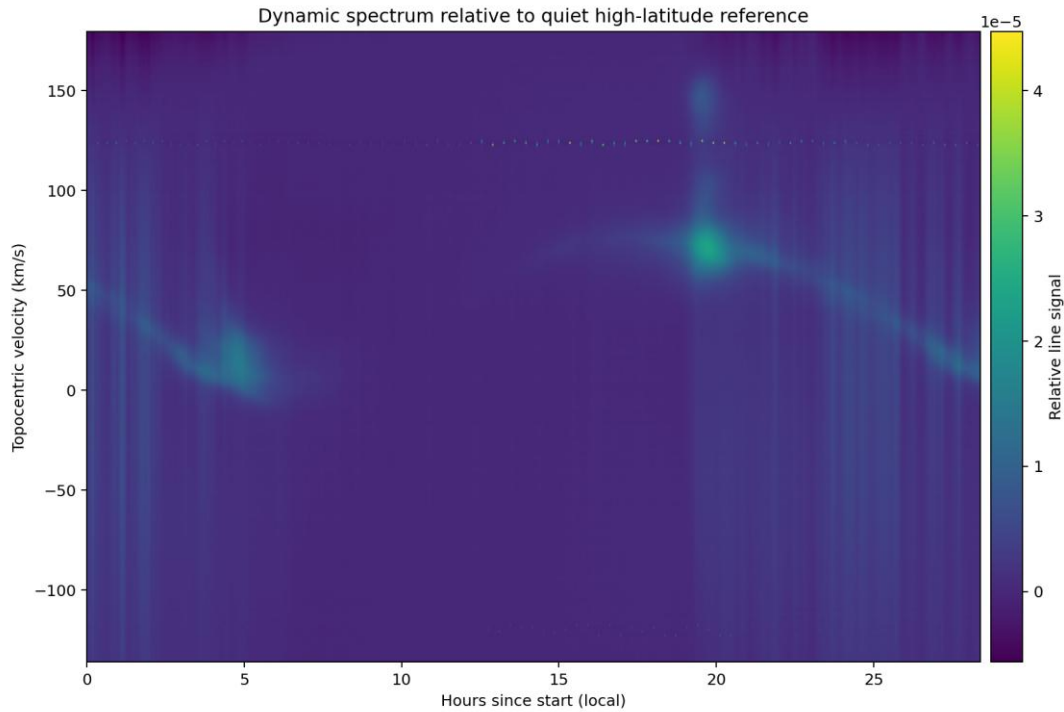

Figure 7: Dynamic spectrum of the 10–11 April 2026 run in the topocentric velocity frame.

Sky geometry and Milky Way context

The Glendora zenith path corresponds to a fixed declination near $+34^\circ$. When projected into Galactic coordinates, the geometry of the signal becomes easier to understand. The strongest detections occur where the zenith path approaches the Galactic plane. Because the beam is broad, these directions should be interpreted as windows through the Galaxy rather than pencil-beam cuts through single clouds or spiral-arm filaments.

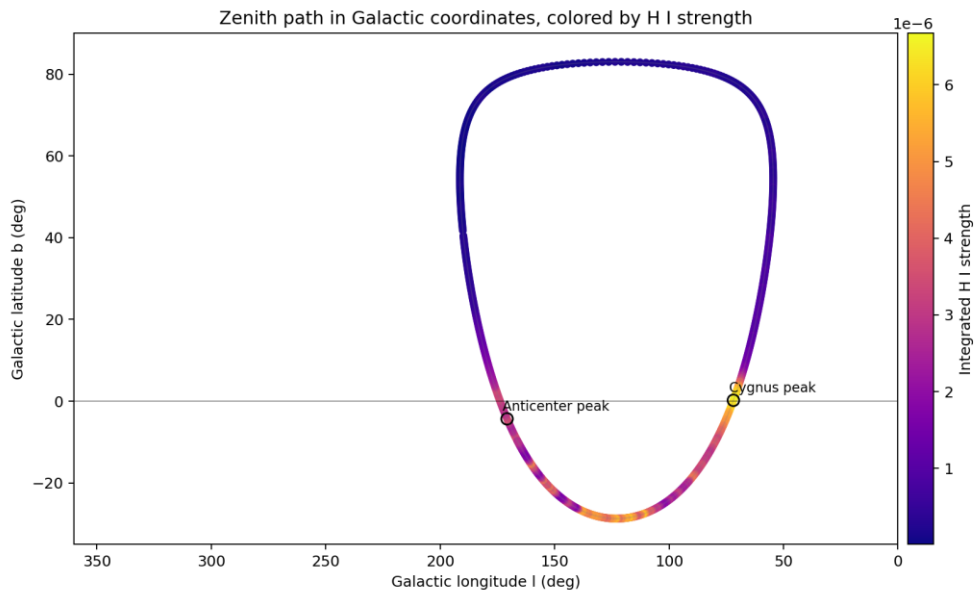

Figure 8: Galactic-coordinate projection of the Glendora zenith path during the 10–11 April 2026 run.

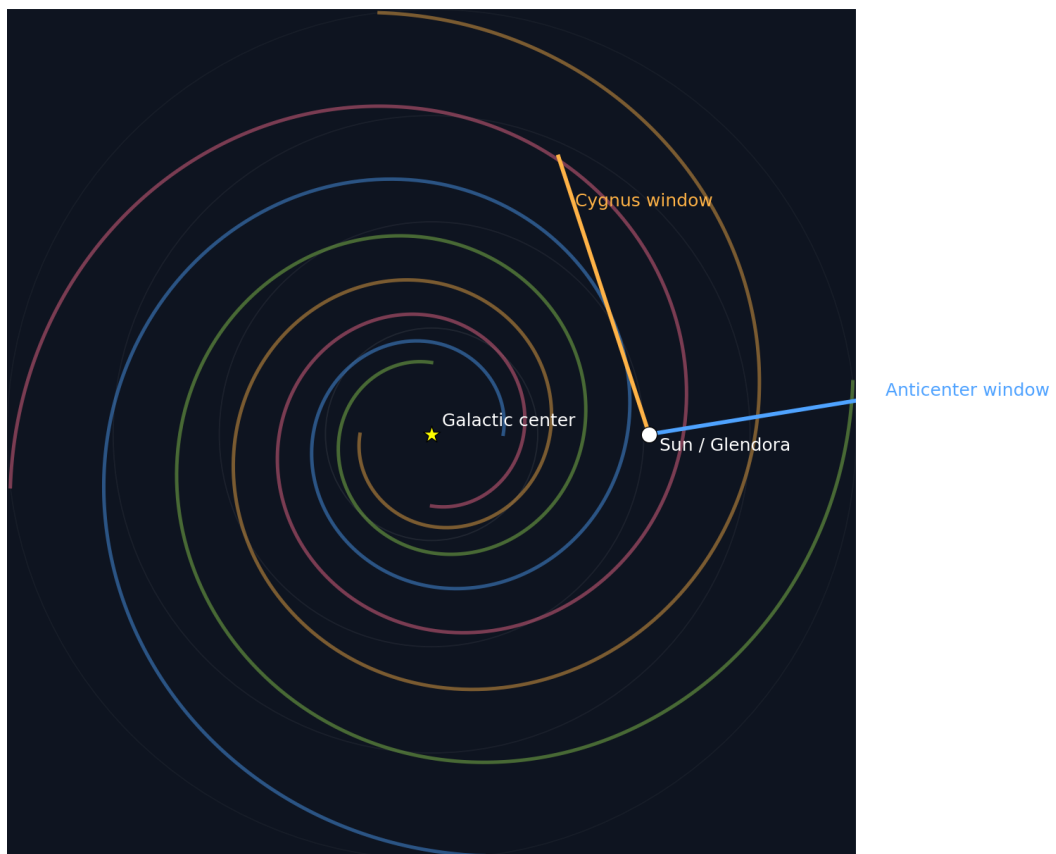

Figure 9: Schematic Milky Way view showing the Sun and the two main H I-rich directions sampled by the zenith drift.

Atmosphere, Doppler behavior, and repeatability

At optical wavelengths, extinction usually implies absorption and scattering that change strongly with elevation. At 1.420 GHz, the relevant effects are atmospheric emission, attenuation, spillover, and ground pickup. In this campaign the dish always remained at zenith, so the air mass stayed close to one and the atmospheric contribution changed little within each run. That makes changing sky direction, not changing atmospheric path length, the natural explanation for the strongest spectral changes.

At 1.420 GHz the atmosphere usually adds a small, nearly constant term at zenith. For this dataset the path length through the atmosphere was fixed, so baseline drift and receiver stability matter more than changing airmass.

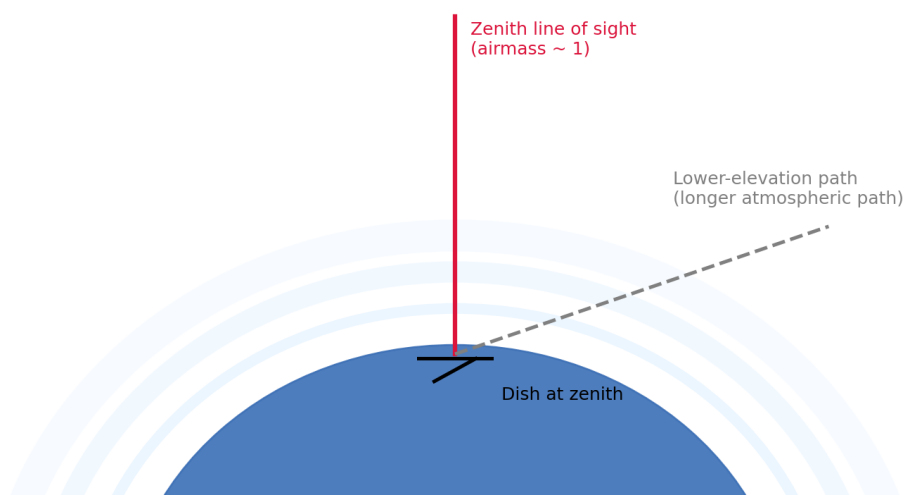

Figure 10: Zenith-pointing geometry keeps the atmospheric path short and nearly fixed throughout the run.

Doppler behavior is central to the interpretation. The anticenter-side window showed positive topocentric peak velocities, while the Cygnus-side window showed negative topocentric peak velocities. That sign change is exactly the sort of large-scale behavior expected when sampling different Galactic longitudes through a rotating H I disk. A more rigorous comparison would place every spectrum in a common LSRK frame and compare the resulting profiles against survey spectra smoothed to the 2.1 m beam.

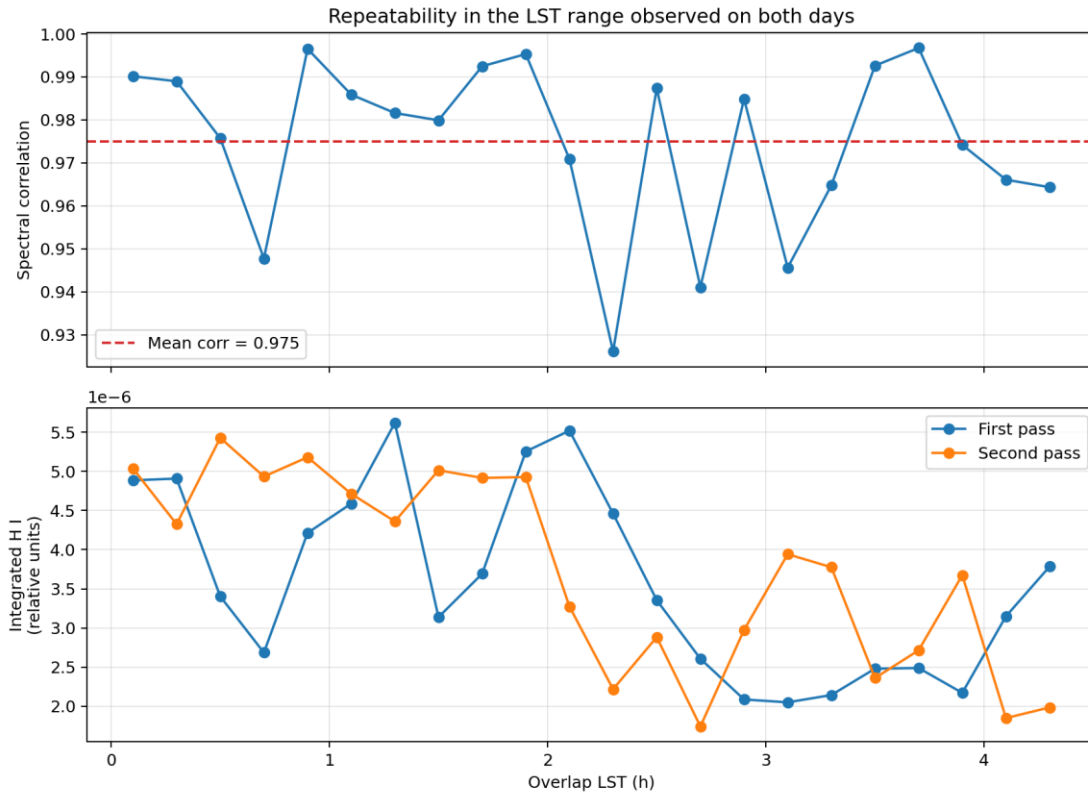

Figure 11: Spectra from the 10–11 April 2026 run at overlapping sidereal times on successive days show strong repeatability.

The repeatability within the April 10–11 run itself is strong: the mean spectral correlation over the overlapping LST range is 0.975. This is a powerful internal check because it uses the same hardware and the same sidereal sky on successive dates.

Calibration needs and limitations

The present results are observationally strong but not yet fully calibrated in an absolute sense. The main limitations are: no direct hot/cold Y-factor measurement of receiver temperature was incorporated, no switched noise source was used to monitor gain drift in real time, the Discovery Dish LNA chain was not independently characterized from hardware measurements during this campaign, and no final LAB or HI4PI comparison has yet been made after smoothing survey spectra to the approximately 6.9° beam.

For a small amateur dish observing extended Galactic H I, the most valuable next steps are not necessarily precision flux density in Jy, but repeatable calibration in antenna-temperature-like units and external validation against survey spectra. A practical calibration sequence would be: one quiet-sky and one strong-H I reference field each session, occasional hot/cold receiver measurements, a switched noise source, if possible, beam measurement with a Sun or Moon drift, and final comparison against LAB or HI4PI.

Conclusions

A small amateur 2.1 m dish in fixed-zenith drift mode can reproducibly detect large-scale Milky Way H I structure. Across six directly comparable runs, the Glendora campaign recovered the same two broad sidereal windows with high profile correlations. A seventh detailed case-study run confirmed the same geometry, showed sensible velocity evolution, and provided a strong within-run sidereal repeatability check.

The campaign also clarified the practical trade between 451k and 901k accumulation settings: lower accumulations are workable for strong Galactic windows and faster cadence, but they do not fully recover the ideal thermal-noise improvement when paired, indicating a systematic floor. The most important next step is calibration and direct survey comparison. Even in its present state, however, the campaign demonstrates that amateur radio astronomy can recover physically meaningful H I drift signatures and do so repeatably over many nights.

References

- [1] J. J. Condon and S. M. Ransom, *Essential Radio Astronomy*, Princeton University Press (2016).
- [2] B. F. Burke, F. Graham-Smith and P. N. Wilkinson, *An Introduction to Radio Astronomy*, 4th ed., Cambridge University Press (2019).
- [3] R. L. Snell, S. Kurtz and J. Marr, *Fundamentals of Radio Astronomy: Astrophysics*, CRC Press (2019).
- [4] P. M. W. Kalberla et al., *The Leiden/Argentine/Bonn (LAB) Survey of Galactic HI, Astronomy & Astrophysics*, 440, 775–782 (2005).
- [5] HI4PI Collaboration, *HI4PI: A full-sky H I survey based on EBHIS and GASS, Astronomy & Astrophysics*, 594, A116 (2016).
- [6] R. H. Dicke, *The measurement of thermal radiation at microwave frequencies, Review of Scientific Instruments*, 17, 268–275 (1946).

About the author

Pablo Lewin is a retired American Airlines captain and an avid astronomer with the Maury Lewin Astronomical Observatory in Glendora, California. He has contributed more than 65,000 variable-star observations and more than 300 exoplanet observations, leading to approximately 50 co-authorships in astronomical science papers. He is also an Amateur Extra class ham radio operator, callsign WA6RSV, and a QRQ CW instructor with the Long Island CW Club. His current work focuses on making 21 cm radio astronomy more accessible to citizen scientists through repeatable observing workflows, data reduction, and outreach. He can be contacted at pablotwa1@gmail.com.

Solar Radio Activity During Spring 2026

Whitham D. Reeve

Type II slow radio sweeps on 30 March 2026 observed at Cohoe, Alaska and HAARP near Gakona, Alaska

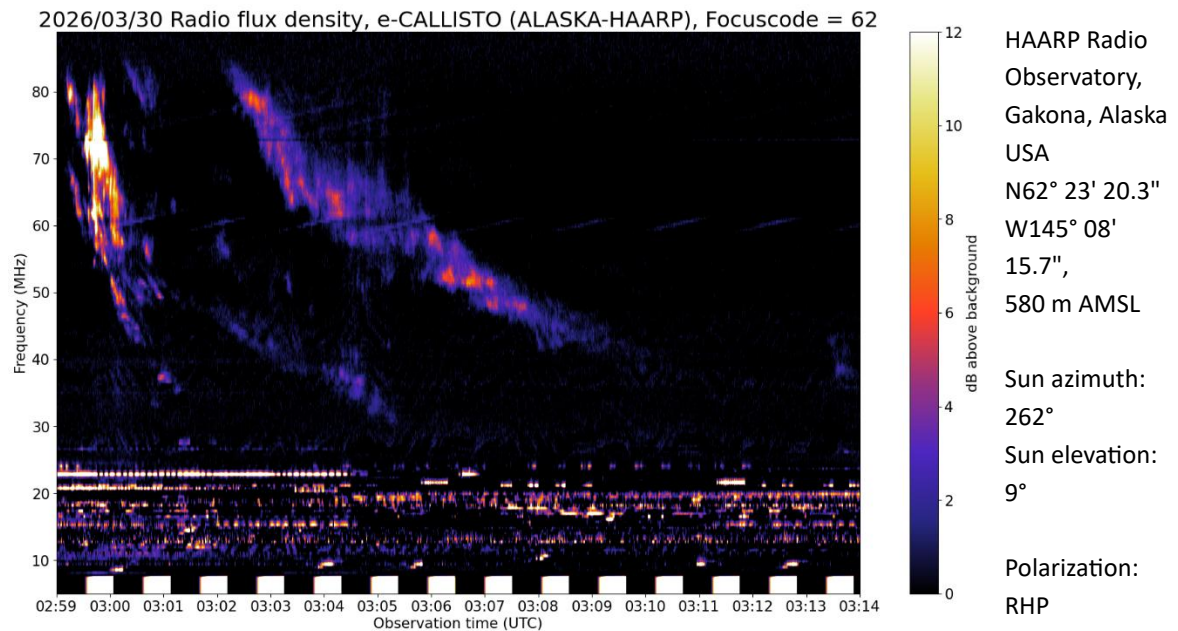
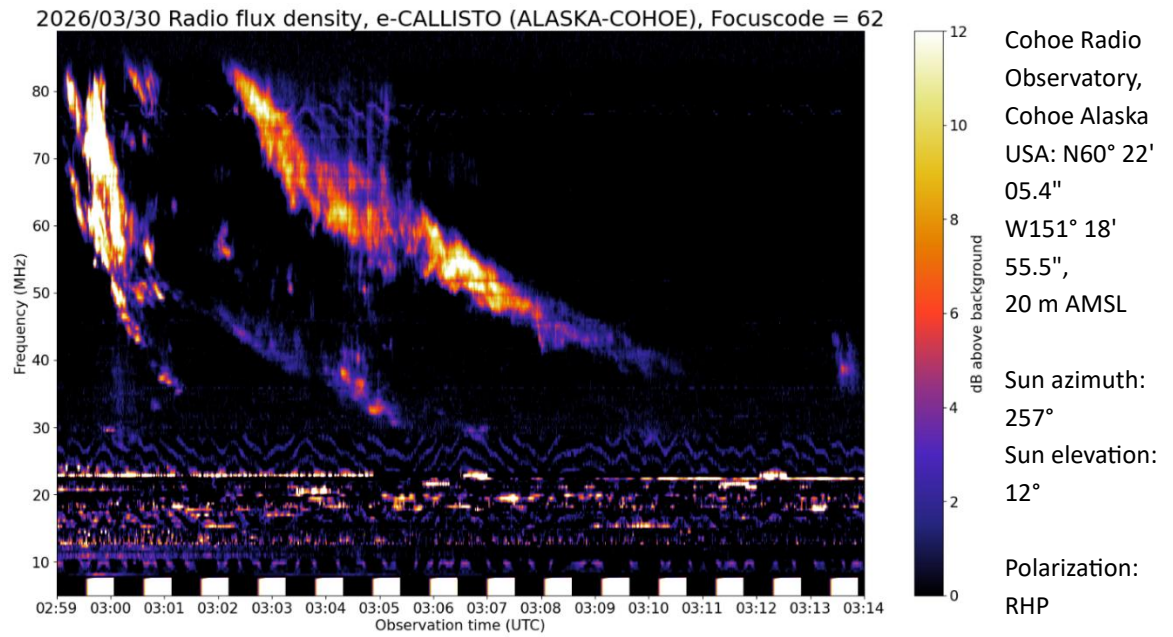

Discussion (applies to 30 March bursts):

- These Type II slow sweeps consist of a banded fundamental with second harmonic.
- There may be vestiges of Type III fast sweeps overlapping the Type II slow sweeps at 0305.
- Horizontal traces below about 24 MHz are terrestrial HF transmissions.
- SWPC reported a coronal mass ejection (CME) associated with the Type II radio sweep (see Forecast Discussion for 31 March below). Assuming the velocity reported by SWPC for this CME represents its speed toward Earth, the estimated transit time at 1872 km s^{-1} would be 22 h and arrival time would be around 0100 on 31 March. The actual arrival time of the CME shock front at the ACE spacecraft was 1130 the next day (see ACE solar wind parameters from 1 April and Forecast Discussion from 2 April below) and arrival at Earth followed 36 minutes later at 1206, giving a transit time closer to 57 h. This equates to an average speed toward Earth of 731 km s^{-1} or about 39% of the initial estimate.
- The arrival of the CME at Earth was indicated by a Sudden Impulse at 1206 observed on the SAM-III magnetometer at Anchorage, Alaska with an amplitude of almost 20 nT. See magnetogram for 1 April below.

Space Weather Prediction Center (SWPC), Events Report at 30 March 2026 (abridged):

#Event	Begin	Max	End	Obs	Q	Type	Loc/Frq	Particulars	Reg#
#-----	-----	-----	-----	-----	-----	-----	-----	-----	-----
3290 +	0247	0319	0344	G18	5	XRA	1-8A	X1.4 3.0E-01	4405
3290 +	0254	0304	0342	PAL	G	RBR	2695	1800	4405
3290	0256	0304	0355	PAL	G	RBR	8800	2000	
3290	0300	////	0310	PAL	C	RSP	025-180	II/2 1872	

SWPC, Forecast Discussion, Solar Activity, at 0030 on 31 March 2026 (see related image below):

Solar activity reached high levels due to a long duration X1.4 flare (R3/Strong) peaking at 30/0319 UTC from Region 4405 (S27E32, Eao/beta-gamma). This event also produced a Type II Sweep starting at 30/0300 UTC (est. velocity = $1,872 \text{ km/s}$) and a Tenflare peaking at 30/0304 UTC (peak flux of 1,800 sfu). Weak C-class activity from Region 4402 (N19W32, Cai/beta) was observed during the X1.4 flare decay phase, and likely associated with Type III radio bursts. Associated with the X1.4 flare, a partial-halo CME was observed in LASCO C2 imagery beginning at 30/0312 UTC. The modeled CME propagation indicates possible impacts near-Earth late on 31 Mar.

SWPC prediction from 0400, 30 March 2026 (the cursor is set to the initial estimated arrival):

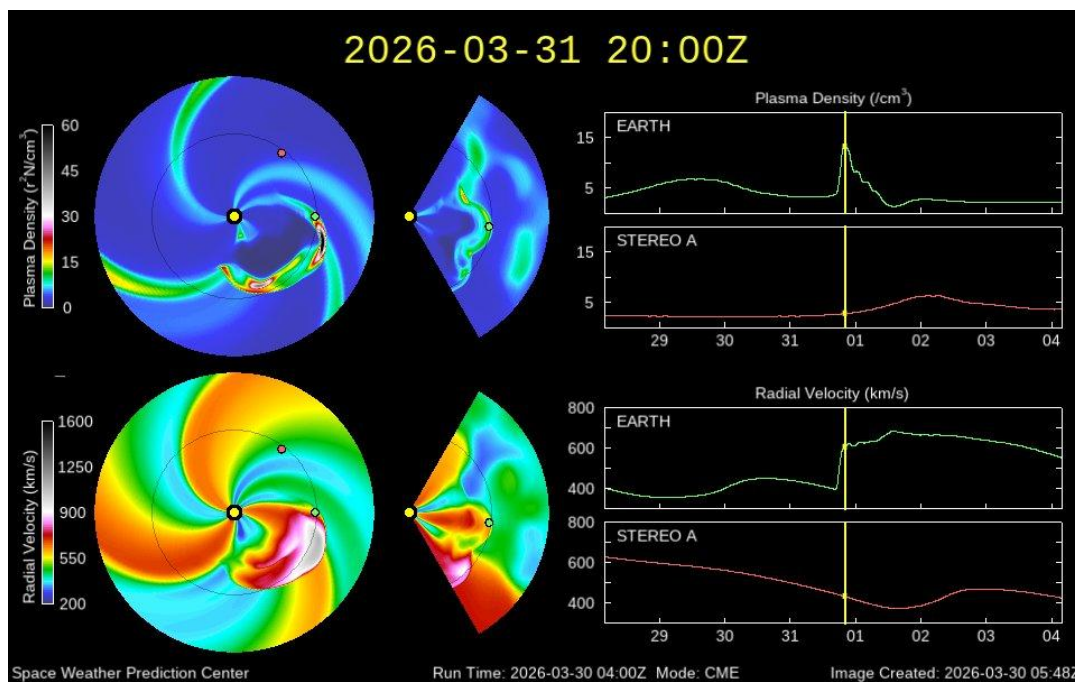

SWPC, Forecast Discussion, Solar Wind, at 0030 on 2 April 2026 (see annotated image below):

Solar wind parameters were at mostly nominal levels until a IP shock was observed at the ACE spacecraft at 01/1130 UTC indicating the arrival of a CME that left the Sun on 30 Mar. Solar wind speed increased from approximately 400 km/s to near 500 km/s during the onset of the transient, returning to ~425 km/s by the end of the UT day. Total field increased to a peak of 16 nT at 01/1154 UTC (near the onset of the IP). Bz oscillated around zero most of the day, reaching as far south as - 10 nT at 01/1227 UTC. Phi angle was predominantly positive until about 01/2000 UTC, when it became mostly negative until the end of the period.

Solar wind parameters measured at ACE from 1800 on 31 March to 1800 on 1 April 2026:

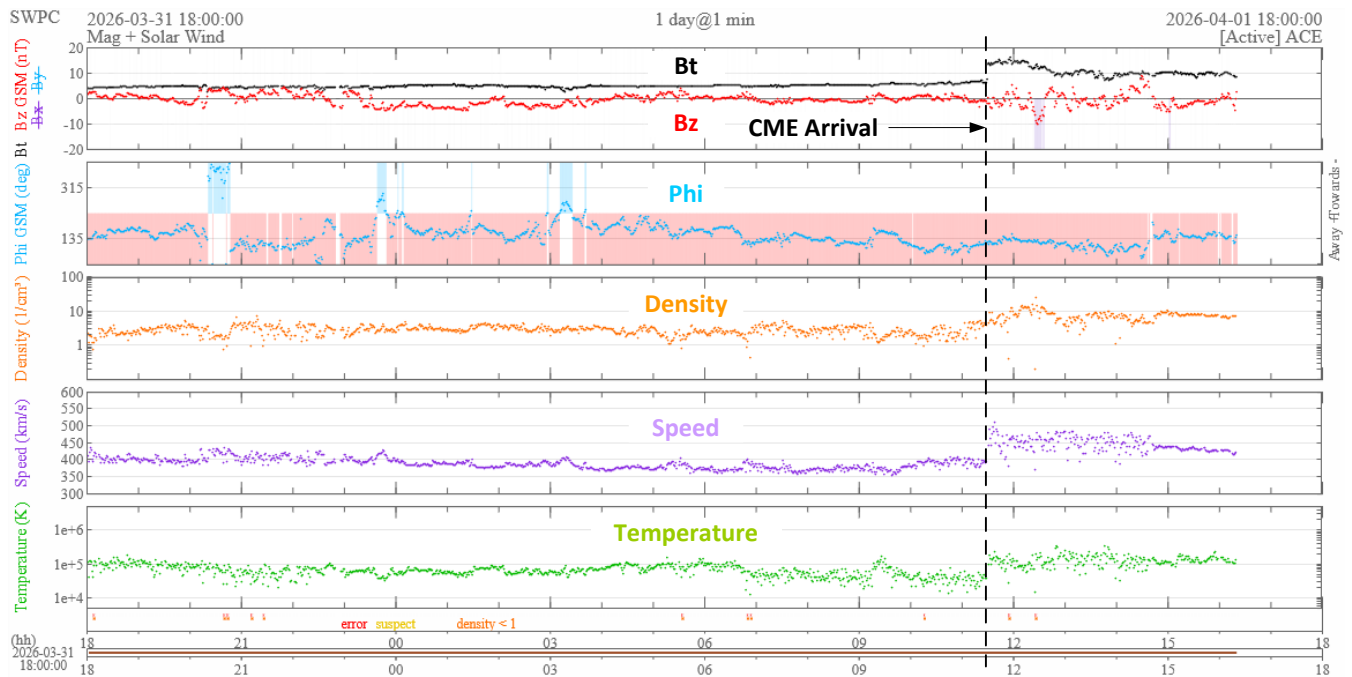

Geomagnetic record at Anchorage, Alaska for 1 April 2026 with Sudden Impulse annotated:

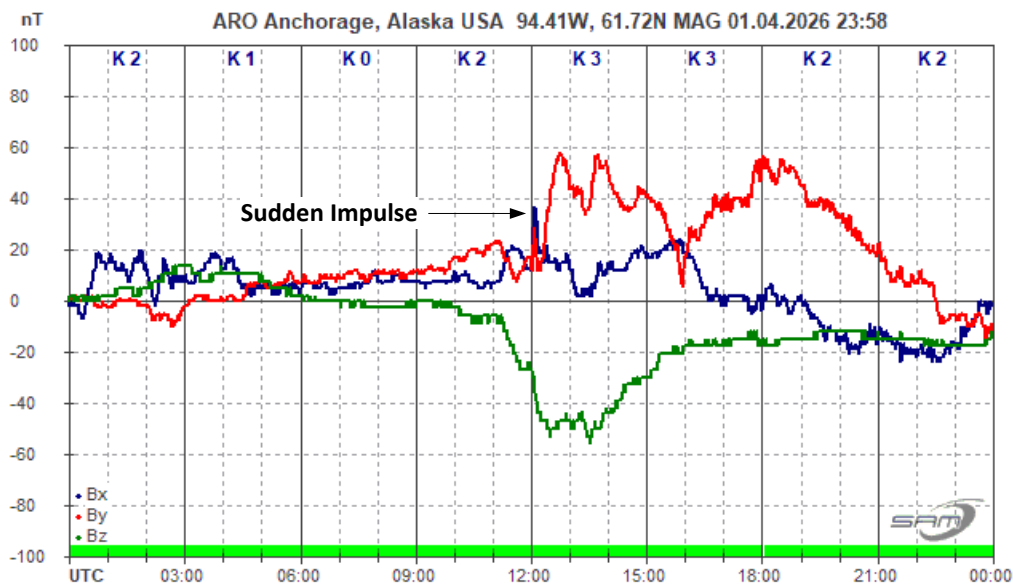

Type III fast and Type II slow radio sweeps on April Fools' Day, 2026 observed at Cohoe, Alaska

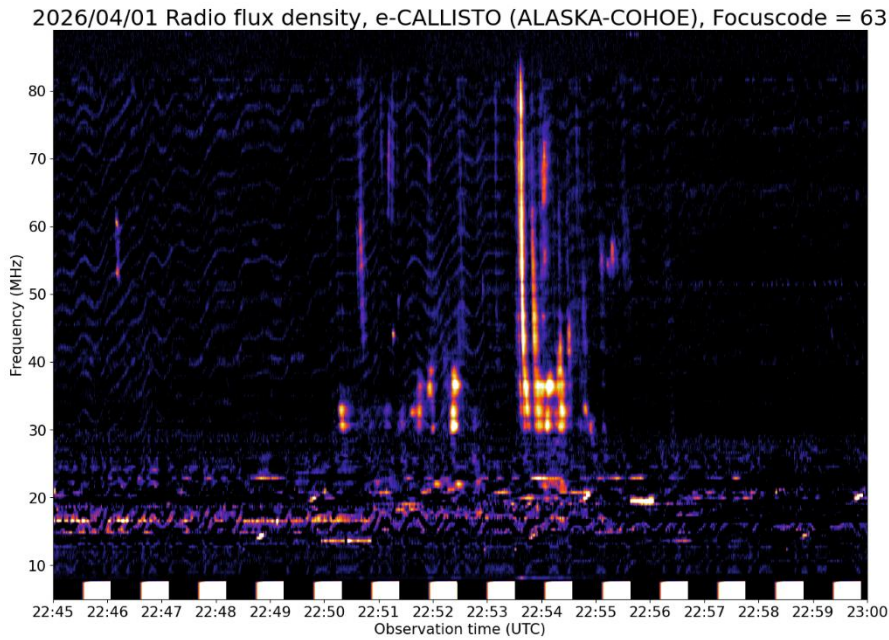

Type III

2245 ... 2300
UTC
1 April 2026

Cohoe Radio
Observatory,
Cohoe Alaska
USA: N60° 22'
05.4"
W151° 18'
55.5",
20 m AMSL

Sun azimuth:
193°
Sun elevation:
34°

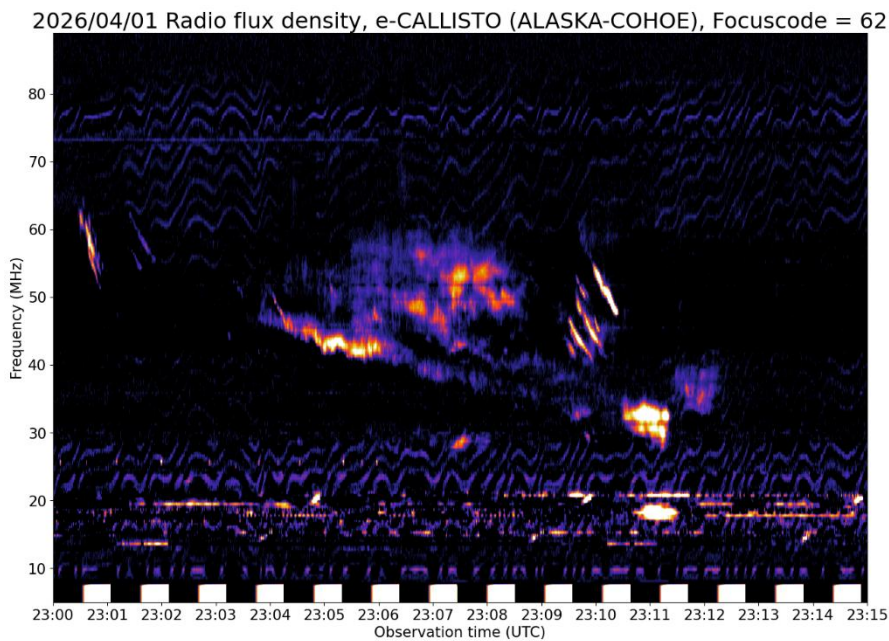

Polarization:
LHP

Type II

2300 ... 2315
UTC
1 April 2026

Cohoe Radio
Observatory,
Cohoe Alaska
USA: N60° 22'
05.4"
W151° 18'
55.5",
20 m AMSL

Sun azimuth:
198°
Sun elevation:
33°

Polarization:
RHP

The CME associated with the above Type II radio bursts arrived at Earth on 3 April at 1529, producing a Sudden Impulse. See magnetogram from 3 April below.

Geomagnetic record at Anchorage, Alaska for 3 April 2026 with Sudden Impulse annotated:

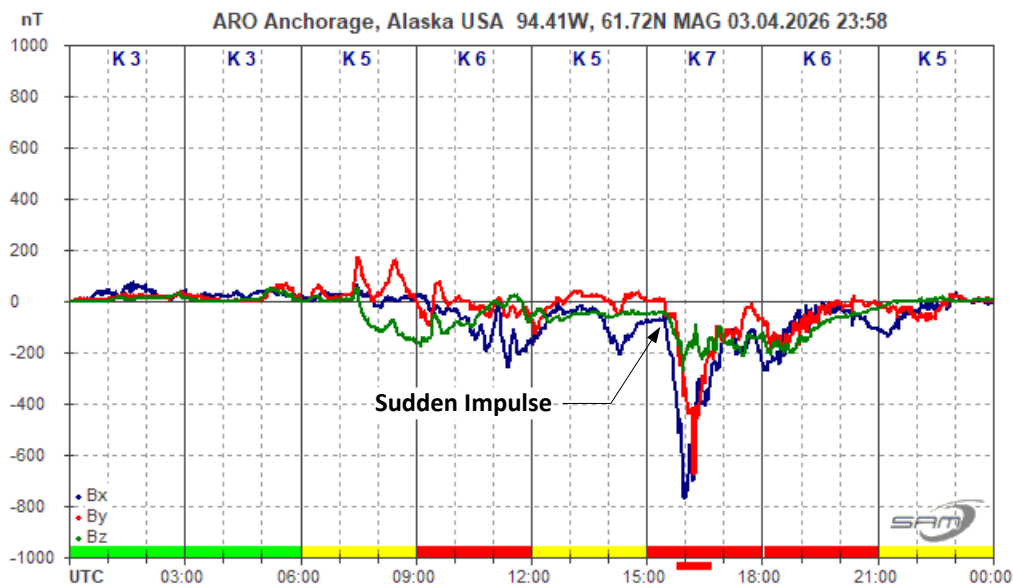

M7.5 Solar Flare and Sudden Frequency Deviation (SFD) Followed by Radio Blackout on 4 April 2026

Flare at Sun location N04W04, Begin Time: 0107; Maximum Time: 0117; End Time: 0123 UTC. This event caused a Sudden Frequency Deviation that was observed at 0112 at Anchorage, Alaska, on 15 MHz and immediately followed by a radio blackout on that frequency; deviation was 5-6 Hz (lower trace). 20 MHz (upper trace) was not affected, See Argo plot below for time period 0100 to 0126.

Argo plot from Anchorage, Alaska for 4 April 2026 with Sudden Frequency Deviation at 15 MHz (lower trace):

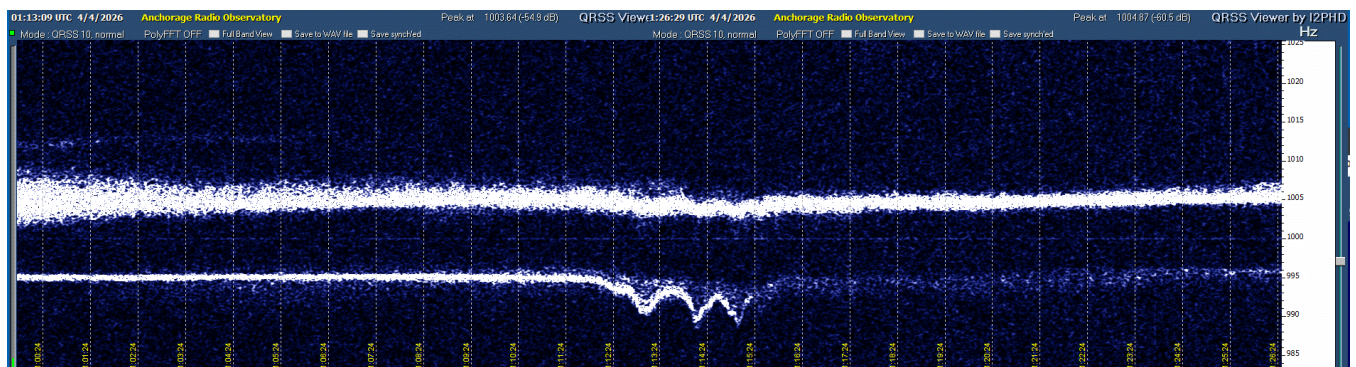

HF Radio Propagation Anomalies on 6 April 2026

Frequency deviations of unknown origin observed at 0016 and 0039 at Anchorage, Alaska on 15 MHz; deviation was approximately 7 Hz (lower trace). 20 MHz (middle trace) and 25 MHz (upper trace) were not affected. See Argo plot below for the time period 0014 to 0046 on 6 April. The waveform signature is similar to that seen during aurora radio reflections, which were also observed about 3 h later on 15 MHz. Another curiosity is that the frequency deviations appear to be independent of the main 15 MHz trace and possibly from a different source. The Anchorage SAM-III magnetometer indicated ULF Waves that coincided with the frequency deviations; ULF Waves also were observed a couple hours later; see magnetogram from 6 April below. GOES spacecraft x-ray flux, electron flux, proton flux, and magnetometer plots showed no activity during this time period so the deviations were not directly caused by a solar flare.

Argo plot from Anchorage, Alaska for 6 April 2026 with frequency deviations at 15 MHz (lower trace):

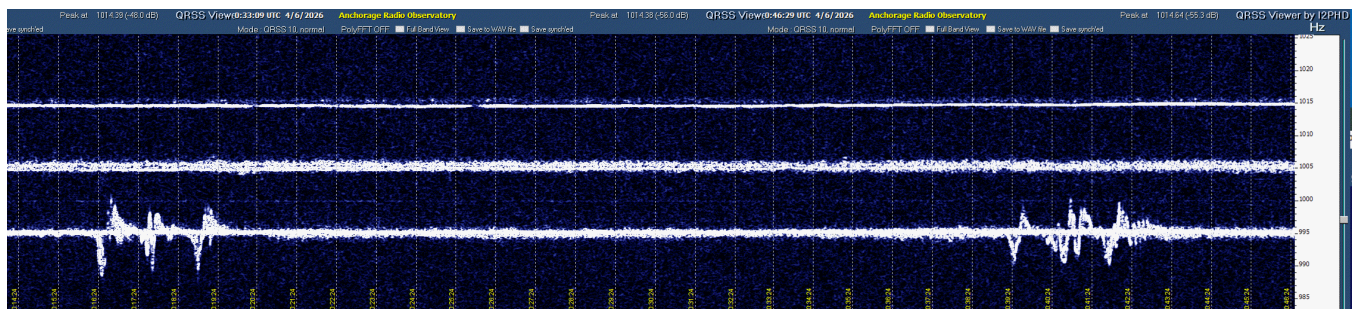

Geomagnetic record at Anchorage, Alaska for 6 April 2026 with ULF Waves annotated:

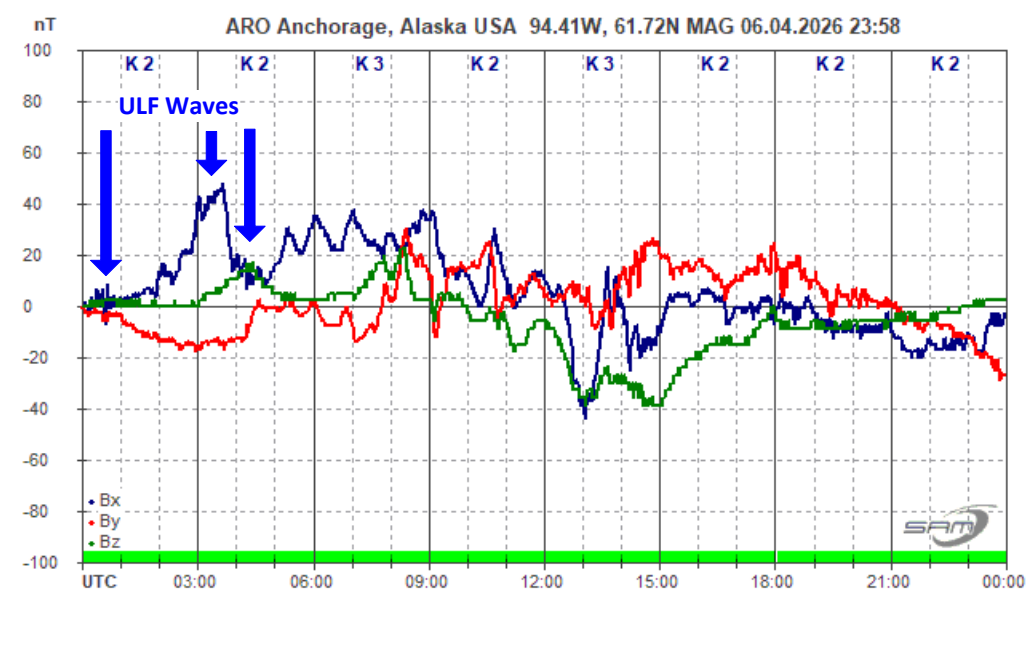

Acknowledgements:

- ✓ e-CALLISTO spectrum images: Universidad de Alcalá:
<https://astrodoncel.uah.es/dashboard/index.php>
- ✓ e-CALLISTO data: Institute for Data Science FHNW Brugg/Windisch, Switzerland:
<https://soleil.i4ds.ch/solarradio/callistoQuicklooks/>
- ✓ SWPC reports and images: <https://www.swpc.noaa.gov/>

NF Test: Callisto Test Tool

Whitham D. Reeve & Christian Monstein

1. Introduction

The NF Test software tool for Callisto was developed by co-author Monstein as a Callisto production test tool. Its application to Callisto noise figure measurements was previously described [{Noise}](#). The tool's many other features and capabilities are described in this article. Some of the information in the previous article is repeated here for convenience, but a description of the noise figure measurement function is contained only in [{Noise}](#). Callisto is the instrument used in the e-CALLISTO solar radio spectrometer network [{e-CALLISTO}](#). The Callisto's native frequency range is 45 to 870 MHz but it often is used with an up-converter or down-converter to extend its operating frequency range and with a low noise preamplifier to increase its sensitivity.

2. NF Test Executable

The NF Test tool is in a Zip file under the Software tab at [{e-CALLISTO}](#) or it may be downloaded directly at [{NFTest}](#). After the files have been extracted to a convenient folder, for example, c:\Callisto\Tools\NF Test, the executable file, NF.exe, may be opened. When the files are extracted, many header files and other files used to compile NF Test are placed in the same folder. Most files are not needed for NF Test operation and may be deleted or moved; however, the following files must be retained: nf.bpr, nf.cfg, NF.exe, VersionControl.txt, and wsc.dll.

NF Test runs under Windows XP through 11 and requires one native serial port or USB port for instrument control. The installation does not change the Windows registry, and the tool may be uninstalled simply by deleting it. Generally, a shortcut to the file is placed on the Desktop. When NF Test is run, a main window opens (figure 1).

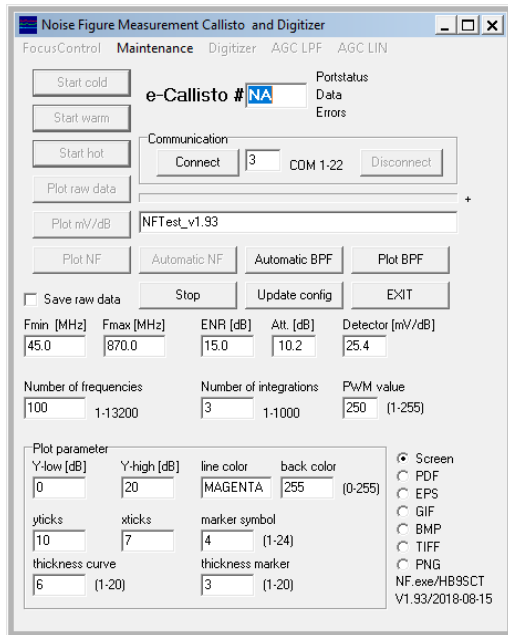

Figure 1 ~ Main window when NF Test is first opened and not yet Connected to the instrument through the serial port. At this point, the Connect button may be pressed if the *Communication* COM port is correct; otherwise, before pressing Connect, it is necessary to change the COM port to match the serial port to be used.

Default values for the various field variables are specified in a configuration file described in the next section. Detailed descriptions of the functions, buttons and menus are provided in later sections.

3. NF Test Configuration File

NF Test uses a configuration file *nf.cfg* that defines its default parameters. The configuration file is an ASCII text file located in the same folder as the executable and is shown below. When first installed, *nf.cfg* is populated with a complete set of default values, which must be edited to comply with the user's specific setup. The configuration file may be accessed by navigating to the installation folder or by clicking on the *Maintenance* menu of the NF Test window. It may be edited with any ASCII text editor such as Notepad or Notepad++. If changes are made to *nf.cfg* after NF Test is opened, the Update Config button must be pressed before any measurement.

```
// Measurement Parameter
[rxcomport]=3           // 1 .... ?? RS-232

[maintitle]=NA         // any text without space, use underscore or - instead, like
00...99

[sstitle]=NFTest_v1.93 // any text without space, use underscore or - instead

[fmin]=45.0           // lowest frequency (45.0...870.0), nominal 45.0
[fnom]=408.0          // nominal frequency (45.0...870.0) for digitizer/scope
[fmax]=870.0          // highest frequency (45.0...870.0), nominal 870.0
```

```

[enr]=15.0          // ENR nominal 15.0 dB .... 35 dB, 5.0 dB with an LNA
[detector]=25.4     // conversion AD8307 nominal 25.4mV/dB
[channels]=200      // number of channels to measure (1..13200), nominal 200
[integrations]=3    // the more the better the resolution, (1..10'000), nominal 16
[pwm]=250           // receiver gain control (1..255), nominal 100...250

// Plott Parameter
[xleft]=600         // position left corner of window, default 300
[ytop]=100          // position top edge of window, default 100
[xsize]=424         // width of the window, default 848
[ysize]=300         // height of the window, default 600 (golden cut)

[ylow]=0            // yrange -100...100, nominal 0
[yhigh]=20          // yrange -100...100, nominal 20

[yticks]=10         // number of ticks in y-axis, nominal 10
[xticks]=7          // number of ticks in x-axis, nominal 7 or 8

[linecolor]=MAGENTA // BLACK, RED, GREEN, BLUE, CYAN, YELLOW, ORANGE, MAGENTA, WHITE
[backcolor]=255     // 0=black, 255=white background, inbetween some colors, I like 230

[marker]=4          // marker symbol (1..24), nominal 4

[thickcurve]=6      // tickness of plot (1..20), nominal 8
[thickmarker]=3     // thicknes of marker (1..20), nominal 6
// Switching parameter for static relays in test fixture with focus code control
[cold]=00,S         // cold noise source focus code
[warm]=03,S         // focus code later used for determining detector coefficient
[hot]=01,S          // hot noise source focus code to determine noise figure

[att]=10.2          // attenuator value to produce 'warm' out of hot

// digitizer/scope parameter
[focus]=00         // focuscode for digitizer/scope
[sampling]=200      // digitizer/scope sampling time [ms] 50...
[logpath]=C:\Temp\  // data path for light curve file
[ending]=csv        // data file ending (txt, prn, dat, lst, csv)
[delimiter]=;       // column-delimiter = TAB or , or ;

```

Most configuration file parameter names are identical to the field labels in the NF Test main window. The configuration file includes comments denoted by // characters. The comments are used as a guide to the allowed range of variables and in many cases indicate a suggested default or nominal value. The comments may be edited but their length must be no more than 120 characters. The NF Test folder can contain only one nf.cfg file at any given time. Some parameters are basic to the NF Test operation and are described in more detail below.

COM port [rxcomport] parameter: The nf.cfg file above shows port 3 but it may be changed to any appropriate value to match the PC serial port or USB-Serial Converter. The maximum COM port number in the current version (v1.93) is COM24. Problems connecting to the Callisto are always traceable to a wrong [rxcomport] parameter, bad serial cable or outdated USB-Serial Converter or driver.

[Fmin] and [Fmax] frequency parameters: The maximum resolution of the Calisto tuner is 62.5 kHz. When measurements are underway, the frequency steps are rounded to the nearest multiple of 62.5 kHz. There are 13 200 possible frequencies (or [Channels]) in the Callisto's native frequency range of 45.0 to 870.0 MHz. The [Fmin] and [Fmax] frequencies can be set to any practical value in that range and divided into any practical number of [Channels], but the frequency resolution is limited to 62.5 kHz, and the maximum number of [Channels] is limited to 13 200.

[PWM] gain parameter: Pulse Width Modulation (PWM) is used with a lowpass filter to control the Callisto gain. This parameter uses integer values from 0 to 255 to set the gain. Typical PWM settings are described in the following sections for different measurement types. The [PWM] parameter can be changed on-the-fly (after connection), but the Update config button must be pressed afterwards.

4. NF Test Main Window Functions

The NF Test Main window has been sectionalized for explanation (figure 2).

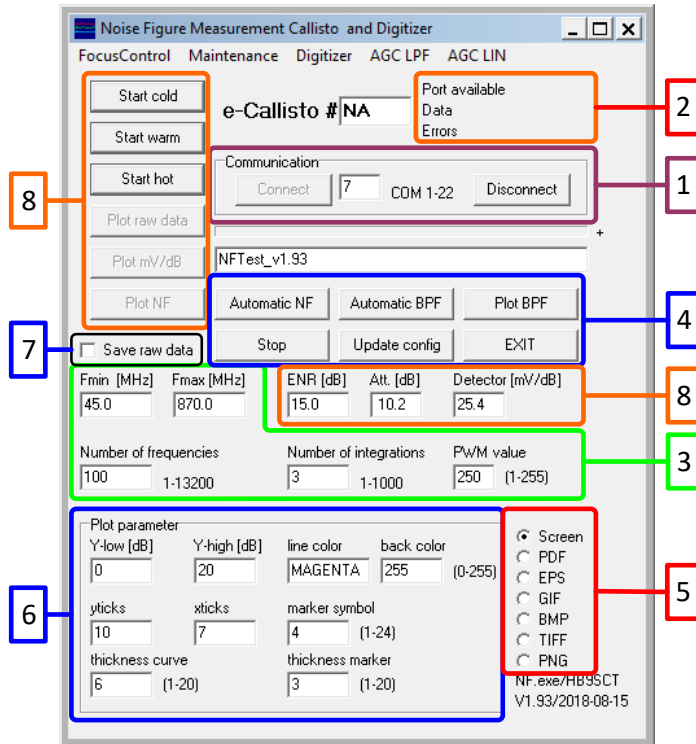

Figure 2 ~ NF Test Main window. See text.

1. *Communication* setting is critical for Callisto operation. Before pressing Connect (grayed out in this image), the correct COM Port must be entered here. If Connect is pressed with the wrong port, nothing will happen except that NF.exe may have to be closed and reopened, the correct port entered and then Connected again.
2. A correct connection is indicated by the text *Port available*. When a measurement is underway, the Data field indicates the commands sent by NF.exe to Callisto and the Error field indicates any errors in the serial connection. Errors are almost always caused by a bad serial cable or outdated USB-Serial Converter or driver.
3. Parameter fields specify the start *Fmin* and stop *Fmax* frequencies, and *Number of frequencies* (or Channels). The *Number of frequencies* determines the resolution of the measurements subject to the limitations previously described. The *Number of Integrations* averages the measurements to reduce random noise and *PWM-value* sets the Callisto gain.
4. *Automatic NF* and *Automatic BPF* buttons initiate automated noise and bandpass filter measurements using the Callisto Test Fixture. Additional buttons are *Update config*, which must be pressed if any of the parameters are changed on-the-fly, and *Plot BPF*, which can be used to replot the bandpass filter measurements if the *Plot* parameters are changed. A measurement may be stopped temporarily by pressing *Stop* and NF.exe may be closed by

pressing *Exit*. The program also may be closed by pressing the X in the upper-right corner of the window.

5. Plots may be saved to the *Screen* or in different image file formats such as PDF, BMP and PNG. Images are saved at the end of a measurement in the location specified by the [logpath] parameter in the configuration file nf.cfg.
6. *Plot parameters* determine the characteristics of the plots that result from the measurements. Most of the parameters can be used as-is but some measurements require changes to the vertical scale (*Y-low* and *Y-high*). Specific measurements described later provide recommendations for the settings, but users are encouraged to experiment.
7. The *Save raw data* checkbox places the ASCII text data from the noise figure and bandpass filter measurements in the file location specified in the [logpath] parameter in the configuration file nf.cfg.
8. The *Start cold*, *Start warm* and *Start hot*, *ENR*, *Alt.* and *Detector* buttons are used for noise figure measurements and are described in a previous article (see {[Noise](#)}).

5. Measurements

The optional Callisto Test Fixture designed by co-author Reeve simplifies Callisto tests and measurements, but it is not necessary. The functions in the *Focus Code* menu (figure 4-left) are used with the Callisto Test Fixture to test the operation and internal wiring of the Callisto's Focus Code connector. The Focus Code connector functions may be manually tested by measurements with a DMM or LED with a current limiting resistor.

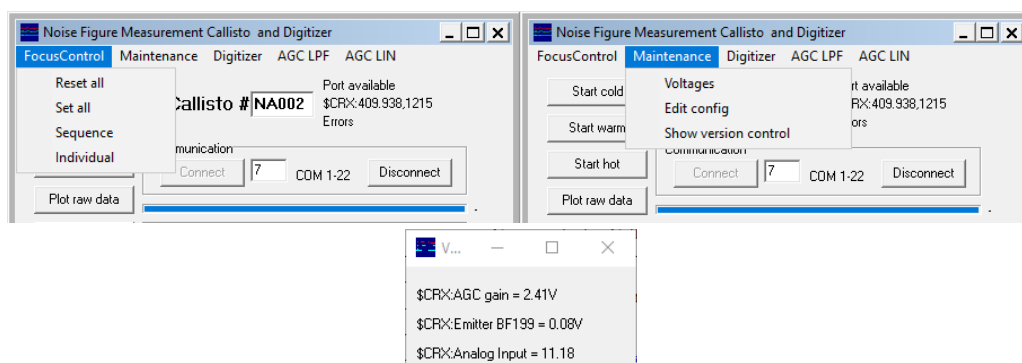

Figure 4 ~ Left: FocusControl menu. The various settings control the Focus Control connector pin states, On or Off. The settings control the Focus Code connector pin voltages so they can be measured with a DMM or indicated by LEDs on the Callisto Test Fixture. Middle: Maintenance menu. Selecting *Voltages* shows the Callisto internal voltages. The configuration file may be edited and then saved. Selecting *Show version control* displays the NF Test change log. Right: Voltages window shows the gain control voltage applied to the tuner (this value varies with the PWM gain control setting), the emitter voltage of the 2nd IF amplifier transistor and the input voltage. The input voltage is measured after the internal polarity guard diode so it slightly lower than the voltage at the Callisto dc power connector.

The *Maintenance* menu (figure 4-middle) allows the user to see Callisto’s internal operating voltages (figure 4-right) and to edit the *nf.cfg* configuration file on-the-fly. When the configuration file is edited and then saved, the changes will not take effect until the *Update config* button is pressed. If measurements are attempted before updating the configuration file, NF Test may freeze and will have to be restarted. The NF Test change log also may be viewed from the *Maintenance* menu by selecting Show version control.

The *Digitizer* menu opens another window (figure 5), which is used to access the test functions associated with the Callisto’s internal log detector and analog-digital converter (ADC). It is useful for tuning the IF transformers and troubleshooting. For example, a defective 2nd mixer IC will display unusually low signal levels. The window has been sectionalized for explanation below.

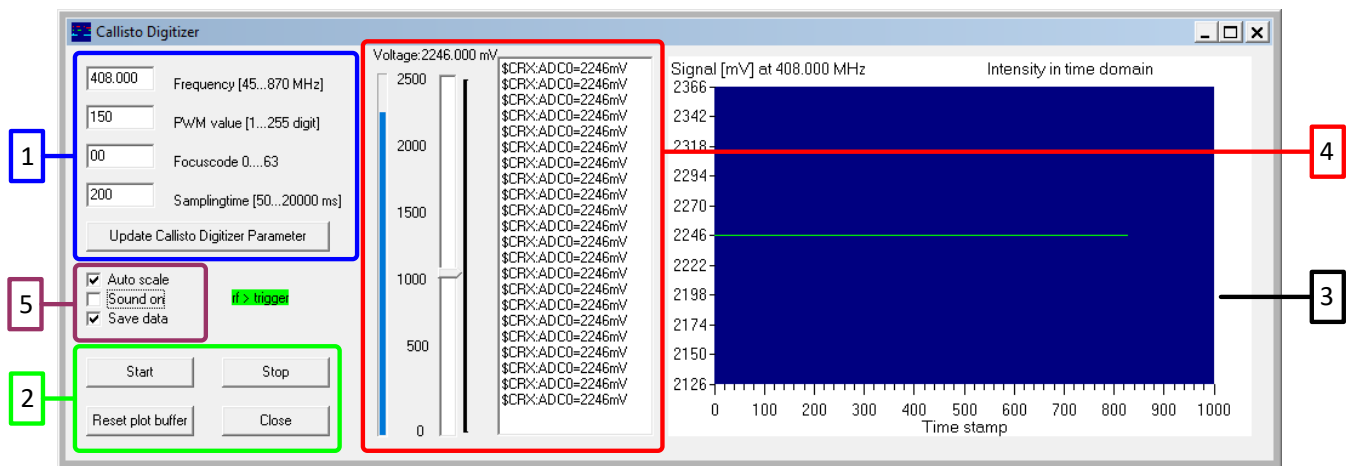

Figure 5 ~ Digitizer window. In this example, the right frame is displaying measurements at the log detector output in mV for a 408.0 MHz input signal with a level of -70 dBm from an RF signal generator. The thin green trace shows the steady signal at 2246 mV that has progressed about 800 seconds in the 1000 second wide window. The middle (red) frame shows the actual measured values at 200 ms intervals. See text.

1. The frequency, gain (PWM), Focuscode and Samplingtime fields command the Callisto to specific settings. To take effect, changes in these fields need to be followed by pressing the Update Callisto Digitizer Parameter button. The Focuscode parameter normally is used with a Test Fixture; it is included with the saved data specified in section 5. The sampling rate of Callisto data also can be set. This setting affects the scrolling rate of the ADC input voltage data shown in section 4 and in the right frame plot shown in section 3.
2. The measurements can be started and stopped by pressing the *Start* and *Stop* buttons, respectively. The *Reset plot buffer* zeros out the plot display autoscale. The Digitizer window can be closed with the *Close* button. If the Start button does nothing, the Digitizer may be frozen. To recover, it may be necessary to close both the Digitizer window and NF Test and then reopen them.

3. The right frame is a real-time plot of the digitizer measurements that shows a plot of the values displayed in section 4.
4. Log detector output voltages associated with each sample. A visual and audible tuning aid is provided by adjusting the slider to the left of the listed values. In the example shown, the trigger level is set at 1000; since the digitizer values are > 1000 , the `rf > trigger` text has turned green. The Callisto IF transformers may be tuned for maximum noise level or, if a signal is input to the Callisto, for maximum signal level.
5. The Auto scale checkbox allows NF Test to automatically adjust the plot scale in the right frame. The Sound on checkbox provides an audible output to indicate when the trigger in section 4 is exceeded. The Save data checkbox saves the digitizer voltage values to a text file for later analysis. The file is saved in the location specified by the `[logpath]` parameter in `nf.cfg`.

Two examples are given below that show how the Digitizer can be used to view the 2nd IF bandpass filter shape. The first method uses a signal generator to sweep the RF input frequency with the Callisto set to a fixed frequency and the second method sweeps the Callisto frequency with the signal generator set to a fixed frequency. In both examples, the Callisto PWM value is set to 150 and the Callisto input signal power is set to -70 dBm.

Example 1:

To display the bandpass filter shape, the output of an RF signal generator is connected to the Callisto RF Input (figure 6). In this example, the RF signal generator output is set to -60 dBm and connected to the Callisto through a 10 dB attenuator.

- ⚙ RF input level at Callisto RF input: -70 dBm
- ⚙ Sweep start frequency: 407.250 MHz
- ⚙ Sweep stop frequency: 408.750 MHz
- ⚙ Center frequency: 408.000 MHz
- ⚙ Frequency span: 1.5 MHz
- ⚙ Frequency spacing: Linear
- ⚙ Sweep shape: Sawtooth
- ⚙ Frequency step: 1.5 kHz
- ⚙ Dwell time: 40.0 ms

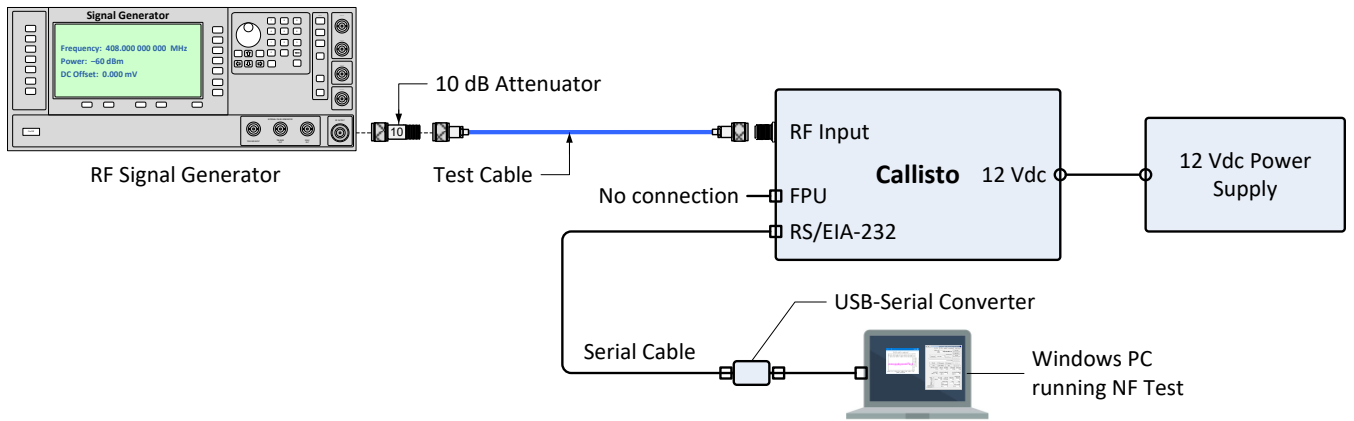

Figure 6 ~ RF signal generator setup for bandpass filter testing.

NF Test Digitizer setup as follows (figure 7):

- ⚙ Frequency: 408.0 MHz
- ⚙ PWM Value: 150
- ⚙ Focus Code: Does not matter
- ⚙ Samplingtime: 100 ms

Note: Be sure to press Update Callisto Digitizer Parameter after changing parameters

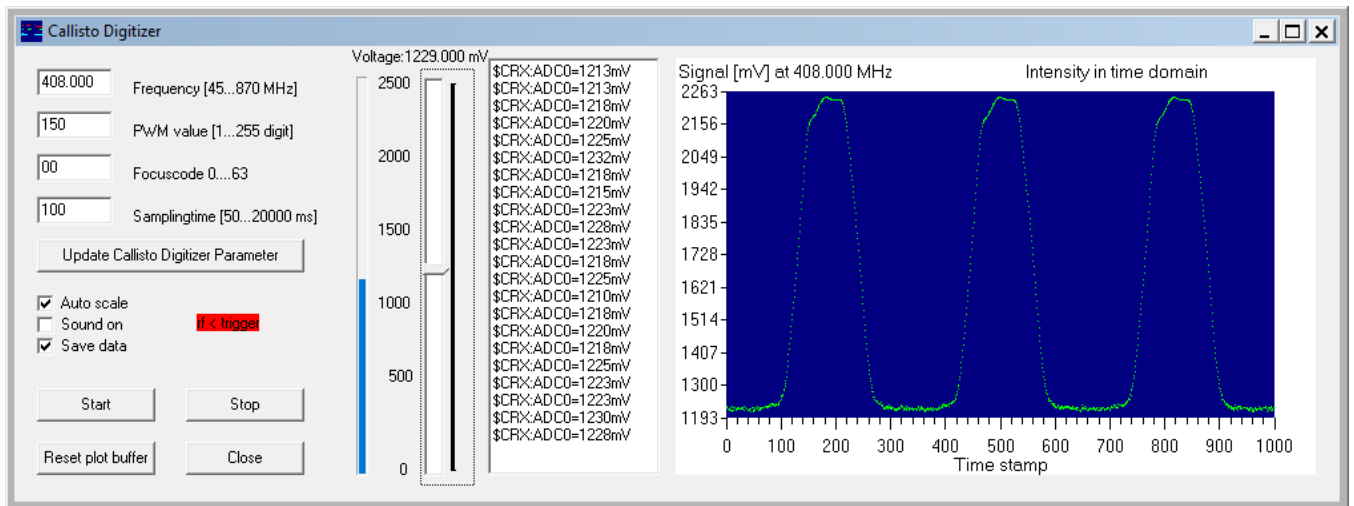

Figure 6 ~ Digitizer setup for 2nd IF bandpass filter testing with an RF signal generator. The display in the right frame shows the filter shape.

Example 2:

For Automatic bandpass filter measurements, an RF signal generator is set to a fixed frequency. The connections are the same as previously shown. Any frequency in the Callisto frequency range may be used; this example uses 408 MHz.

Signal Generator RF output connected through a 10 dB attenuator to the Callisto RF Input

- ⚙ RF input level at Callisto RF input: -70 dBm
- ⚙ Frequency: 408.000 MHz

NF Test setup as follows (figure 8):

- ⚙ Fmin: 406.0 MHz
- ⚙ Fmax: 410.0 MHz
- ⚙ Number of frequencies: 64
- ⚙ PWM: 150
- ⚙ Plot parameters, all default except
 - ⚙ Y-low (dB): -45
 - ⚙ Y-high (dB): +5

Measurement procedure:

1. Turn signal generator RF output Off
2. Press Automatic Bandpass button on NF Test
3. View progress bar and wait for first sweep to finish
4. Within 2 seconds of finish and before the second sweep starts, turn RF signal generator RF output On
5. The bandpass plot window appears when finished

In the Automatic BPF test, the first part establishes the plot noise floor, and the second part sweeps the Callisto frequency from 406 to 410 MHz in $(410.0 - 406.0)/64 = 62.5$ kHz steps, a total of 64 frequencies. The noise floor should be ≤ -38 dB and the shape should not have significant distortion. Small out-of-band spurs and slight asymmetry near the peak are acceptable.

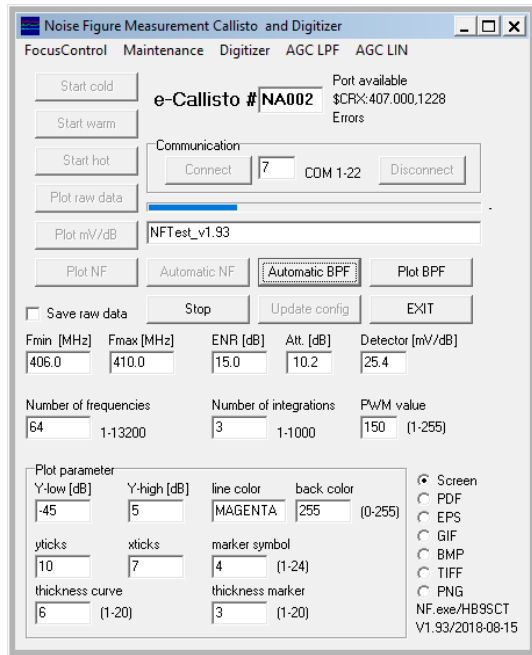
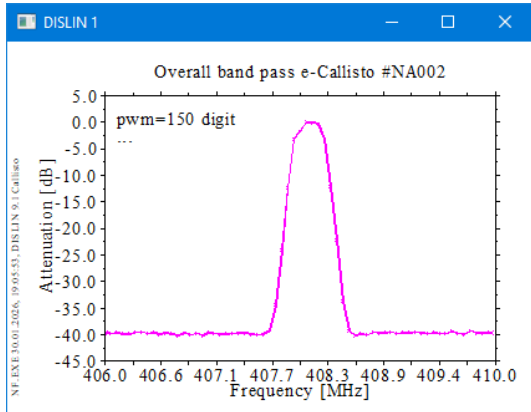

Figure 8 ~ Automatic 2nd IF bandpass filter testing with an RF signal generator set to a fixed frequency.



The *AGC LPF* menu is used to test the lowpass PWM filter that converts the PWM signal from the Callisto processor to a dc voltage that controls the Callisto tuner gain (figure 9). The Callisto only needs to be Connected to NF Test; none of the settings except Communication are used.

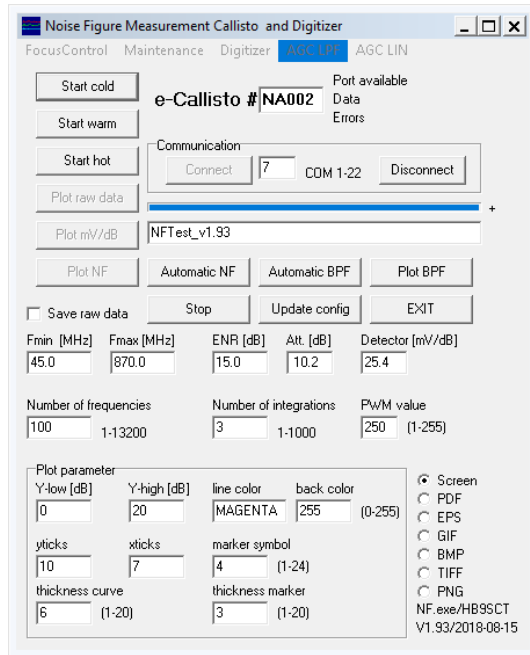
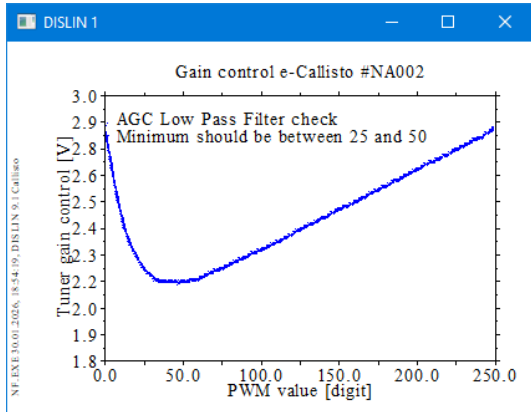

Figure 9 ~ A correctly working Callisto will show a smooth curve with a minimum PWM value between 25 and 50. The trace above the dip will be linear with no gaps or steps.



The *AGC LIN* menu is used to test the linearity of the tuner gain control circuit (figure 10). As with the AGC LPF, the Callisto only needs to be Connected and none of the settings are used except Communication.

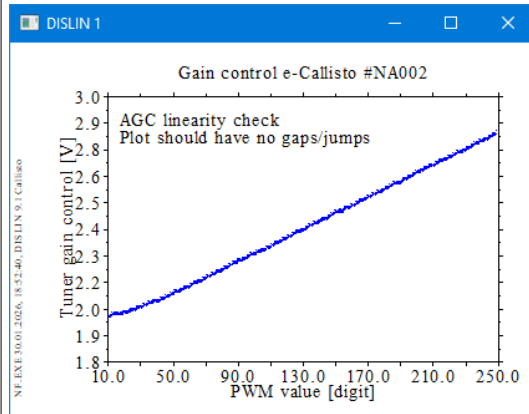
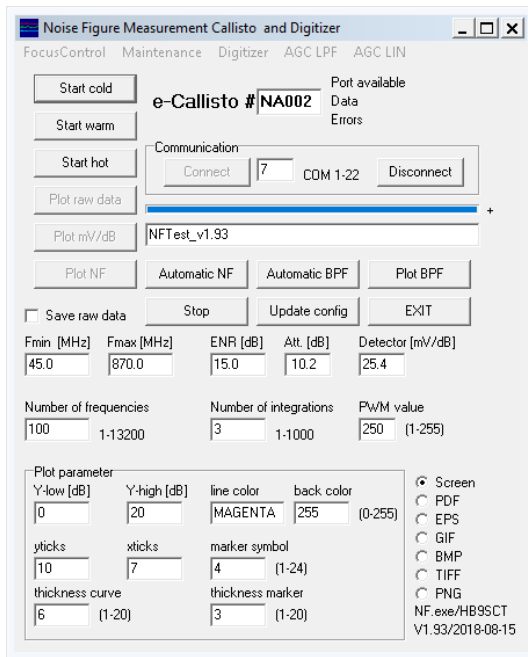
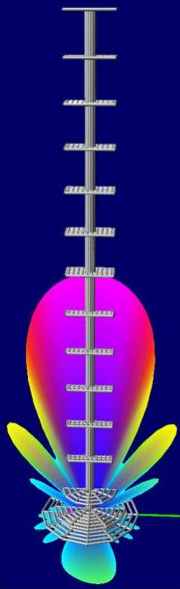

Figure 10 ~ A correctly working Callisto will show a smooth ascending trace with no gaps or step-changes.

6. References

- {e-CALLISTO} e-CALLISTO Solar Radio Astronomy Network: <https://e-callisto.org/index.html>
- {NFTest} NF Test software tool, direct download available at: <https://e-callisto.org/Software/NoiseFigurePlotterV193.zip>
- {Noise} Reeve, W. and Monstein, C., Noise Figure Measurements of the Callisto, 2026, available at: https://www.reeve.com/Documents/CALLISTO/Reeve-Monstein_CallistoNFMeas.pdf

21cm Wavelength Circular_Patch_Feed Disk Director Yagi Antenna



An
*Efficient Low_Noise
Portable Economical
21cm Neutral Hydrogen
Radio Telescope Antenna*
STUDENT EDITION
*Enhanced Reliability
Version*

*If built carefully to correct dimensions
This antenna will have similar
performance to the original
&
It is light enough to be mounted on a
low cost photo tripod*

alex pettit jr April 2026

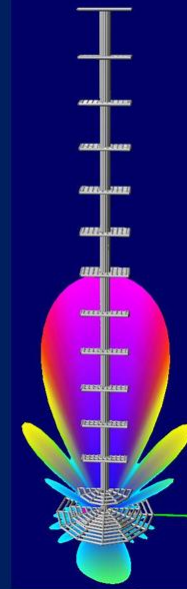

a pettit jr Apr26

21cm Wavelength Circular_Patch_Feed Disk Director Yagi Antenna Student Enhanced Reliability Edition

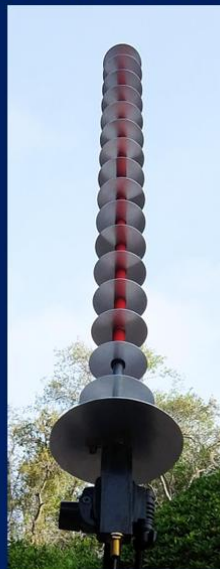

Yagi Antenna Element Names

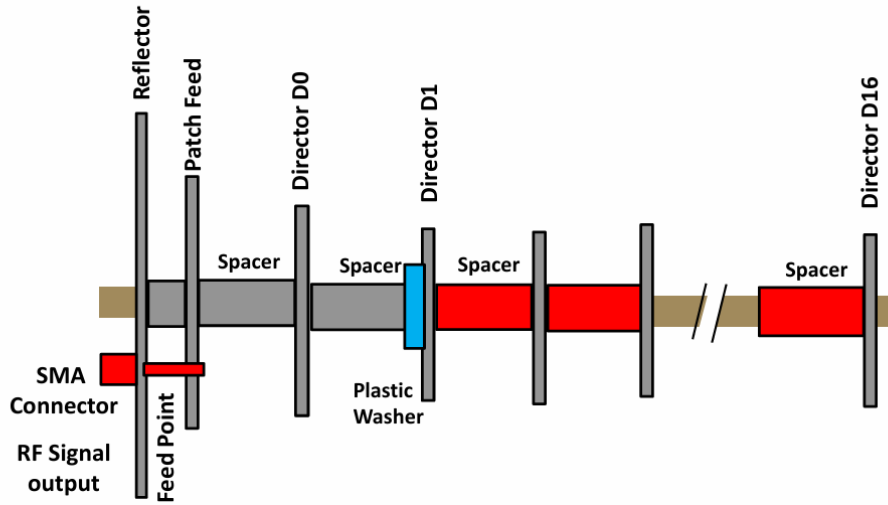

a Pettit Jr Apr 26

Circular Patch Feed Disk Yagi Antenna

Student Edition

Performance Characteristics

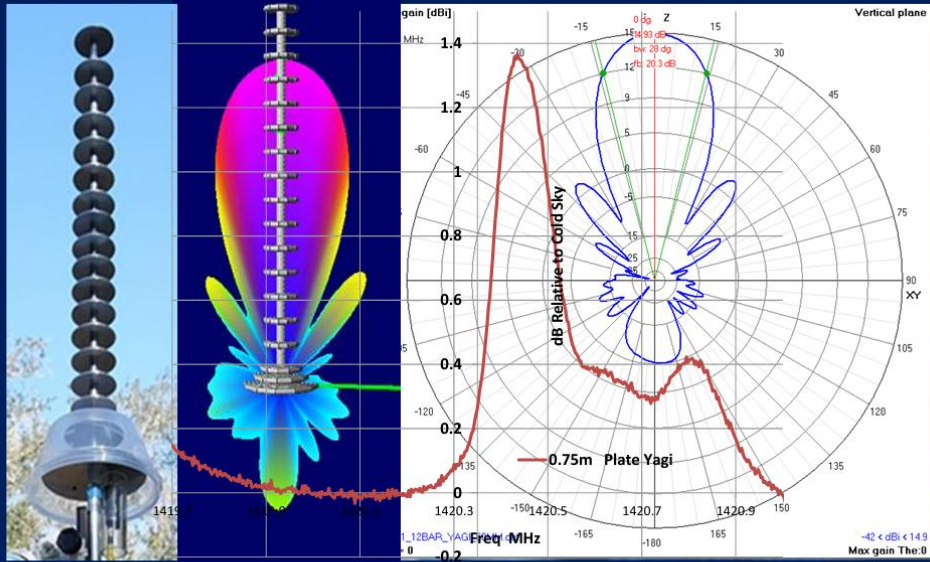

a Pettit Jr Aug 24

Antenna Components for Enhanced Reliability version

Purchase dowels and screws at Local Hardware Store



Antique Brass Lamp Repair Hardware Kit - 5 Sizes, 60 Pieces, Includes Pipe Nipples, Lock Nuts, Washers, Perfect for Lamp Assembly & DIY

Brand: QVQCWD
4.6 ★★★★★ (214) | Search this page
300+ bought in past month

\$7.99 Price history

#6-32 x 1/4" screw & nut for Patch Feed



#2-56 x 1/4" screws & nuts (2.5mm x 6mm if you can find them) for attaching SMA connector



🔗 Dowel Rods Wood Sticks
Wooden Dowel Rods - 3/8 x 36 Inch Unfinished



a Pettit Jr Apr 26

Antenna Components Using 0.020" & 0.030" Aluminum Sheet

REMOVE BLUE FILM

1 pack = 2 sheets 0.030" for Reflector and Patch Feed

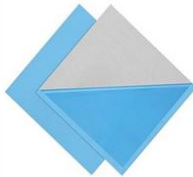

🔗 2Pack 6061 T651 Aluminum Sheet Metal 6 x 6 x 1/32 (0.0315") Inch Flat Plain Aluminum Plate Covered with Protective Film, Heat Treatable Rectangle Aluminum Metal Plate for Crafting, DIY, 0.8mm Thick

Brand: Lswfeiz
4.7 ★★★★★ (231 ratings) | Search this page
\$7.99 (\$4.00 / Item)

2 packs = 4 sheets 0.020" for 16 Directors

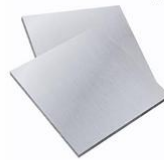

🔗 2 Pieces 6061 T651 Aluminum Sheet Metal 6X 6x0.02(24Gauge) Inch Rectangle Metal Plate, 0.5mm Aluminum Sheet, Plate for Crafting, Industry

Brand: Ileshuai
4.7 ★★★★★ (112 ratings) | Search this page
Amazon's Choice
in Aluminum Sheets & Plates by Ileshuai
200+ bought in past month
\$5.99 (\$3.00 / Item)

Roll over image to zoom in

SharkBite

1/2-in x 5-ft White PEX-B Pipe

\$3.28



K & S Precision Metals
83035 Round Aluminum Tube, 1/2" OD x 0.035" Wall Thickness x 12" Length, 0.5 in OD, 1 pc, Made in USA

Visit the K&S Store
4.5 ★★★★★ (239 ratings)
\$6.99
prime Two-Day

a Pettit Jr Aug24

Hand Tools

Cutting Aluminum & PEX tube to length



HAUTMEC 6inch Mini Hacksaw With Miter Box Set and 1pcs Bi-Metal Blade Small Miter Saw With Adjustable 6 Cutting Angles Professional Hack Saw for Metal, Crafts, Wood, Plastic Cutting

Visit the HAUTMEC Store
4.0 ★★★★★ 1,934 ratings
200+ bought in past month

\$8⁹⁹

Drill for Tripod mounting block



Cutting aluminum sheet into disks



Sponsored

10" Left Cut Aviation Snip - Left Cut Offset Stainless Steel Cutting Shears with Forged Blade & Power Comfort Grips Aviation...

★★★★★ 10

\$9⁹⁹

a petit jr Apr 26

Electronic Components



Nooelec SAWbird+ H1 - Premium Saw Filter & Cascaded Ultra-Low Noise Amplifier (LNA) Module for Hydrogen Line (21cm) Applications. 1420MHz Center Frequency. Designed for Software Defined Radio (SDR)

Visit the NooElec Store
4.4 ★★★★★ 62 ratings | Search this page

\$44⁹⁵ (\$89.90 /100 g)



NooElec NESDR Smart XTR SDR - Premium RTL-SDR w/Extended Tuning Range, Aluminum Enclosure, 0.5PPM TCXO, SMA Input. RTL2832U & E4000-Based Software Defined Radio

Visit the NooElec Store
4.3 ★★★★★ 189 ratings | Search this page

\$43⁹⁵

prime Test-Day
FREE Returns

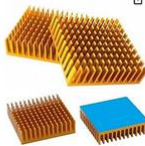

WZMZMB 4Pcs 40mm Heatsink Back Side Thermal Conductive Tape 40mm x 40mm x 11mm Heat Sink

Visit the WZMZMB Store
4.7 ★★★★★ 11 ratings | Search this page

\$5⁹⁹ (\$1.50 /Item)

prime

FREE Returns

Did you know? There's no annual fee for Prime Visa. Get a \$100 Amazon Gift Card instantly upon approval. Learn more

Brand WZMZMB



SMA Male to SMA Male Coaxial Cable 50 ohm KMR240 Coax Cable Ultra Low Loss Antenna Extension Cable with SMA Connector for 3G/4G/5G/LTE Network Equipment, GPS, RF Radio to Antenna (25FT)

Visit the MOKKEERF Store
4.5 ★★★★★ 77 ratings | Search this page

\$23⁹⁹ (\$0.96 /Foot)

prime One-Day



USB 3.0 Extension Cable 1 ft, Yeung Oee High Speed USB 3.0 A Male to A Female Extension Cord for Data Transfer USB Flash Drive, Keyboard, Mouse, Playstation, Xbox, Card Reader, Printer etc (1ft/0.3M)

Brand Yeung Oee
4.5 ★★★★★ 113 ratings | Search this page

\$5⁷⁹



DHT Electronics RF coaxial connector adapter SMA male coaxial Termination Loads 1W DC-3.0GHz 50 ohm Pack of 2

Brand DHT Electronics
4.4 ★★★★★ 121 ratings | Search this page

50 loads per pack

\$5⁹⁹ (\$1.19 /Count)

prime

FREE Returns

Ships from Amazon.com

Specific person



onelinckmore SMA Panel Mount Connector SMA Male 2-Hole Panel Chassis Mount Flange Solder Post Plug Connector Mounting Panel Post Straight Insulator PCB Coaxial Converter Pack of 5

Visit the onelinckmore Store
5.0 ★★★★★ 3 ratings | Search this page

\$6⁹⁸ (\$1.40 /Count)

a petit jr Aug24

Cir Patch Feed Plate Yagi Component Dimensions

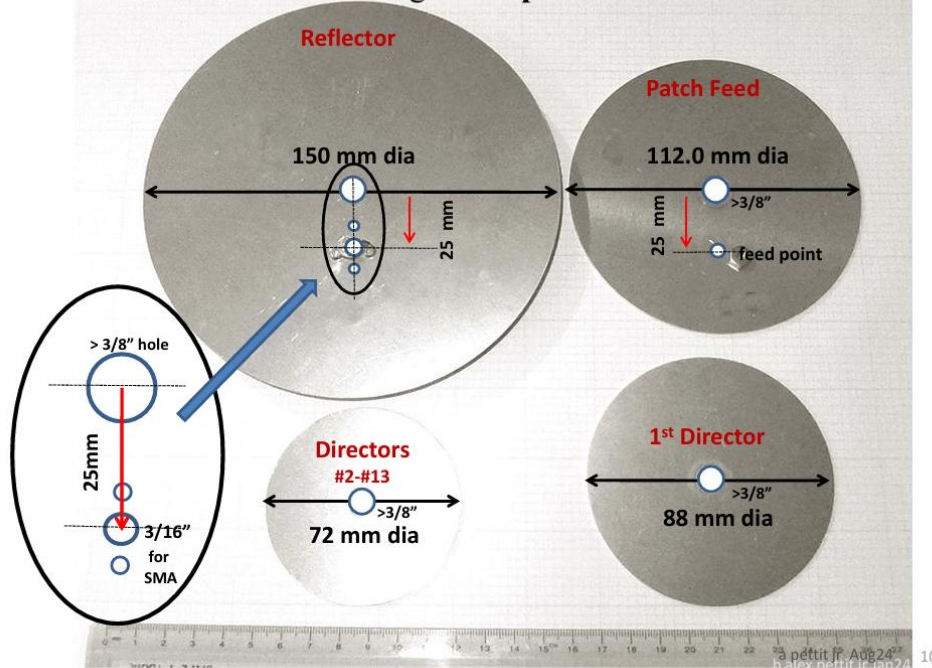

(optional) Hand Tools

marking disk diameter
cutting lines on aluminum sheets



2pcs Compass for Geometry, Professional Drawing
Compass, Metal Compass, Circle Compass Drawing
Tool for Geometry, Math, Drafting, Drawing,
Measuring, School & Office Supplies by CUALORK

Brand: Cualork
4.5 ★★★★★ 253 ratings | Search this page
200+ bought in past month

\$5.68

a petit jr Aug24

Fabrication Details

Remove excess outer aluminum in stages to make final cut easier
the small amount remaining will curl away and not cause the disk to distort

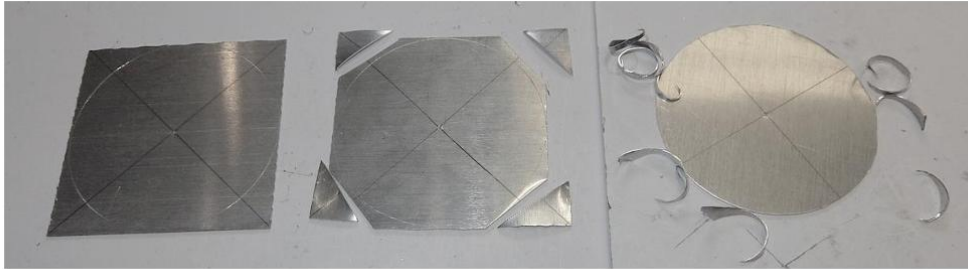

Because of the amount of aluminum that must be cut away and the 0.030" thickness of the 112.5mm Patch Feed disk, It is the Most Difficult Trim away excess in small steps..

The less material that is removed at each step , the easier each is to cut.



Left Cut Aviation Shears
(for a right handed person)

a Pettit Jr Aug24

Fabrication Details

72 mm diameter Director Layout

it may be easier to drill all 4 dowel rod holes before cutting sheet into small pieces
indent centers w/ punch or sharp nail
Start with a 1/8" drill bit and work progressively in 3 or 4 steps to 3/8" + (25/64")

(OR cut out all circles , stack, clamp properly, and drill all 72mm disks at one time

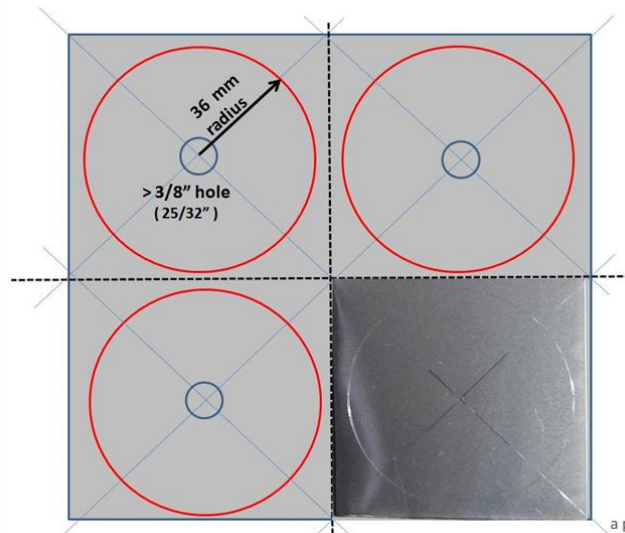

a Pettit Jr Aug24

Fabrication Details

Use Wood Block for Base for attachment to Tripod Shoe

for Tripod Mount capability :
Drill 7/16" hole and make a thread pattern
with a 1/4"x 20tpi screw to match Tripod Shoe

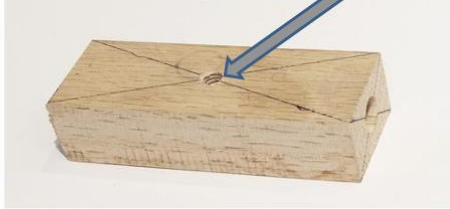

Wood Block Dimensions

3/4" X 1 1/4" X 3" (not critical ... *Except*, the Optimal Orientation of the Antenna's Beam Pattern is such that the Feed Point is East <> West.
Meaning : The Width of the block needs to accommodate the SMA connector & LNA amp unit)

>3/8" hole for Threaded Rod (drill from each end)

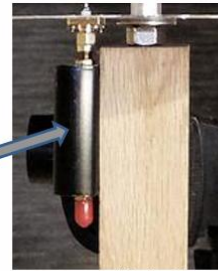

a pettit jr Aug24

Fabrication Details

Cutting Spacers to Length
use a C-clamped wood block as both a length guide
and to hold the miter block to a table



Spacer Sleeve Dimensions

Aluminum

PEX

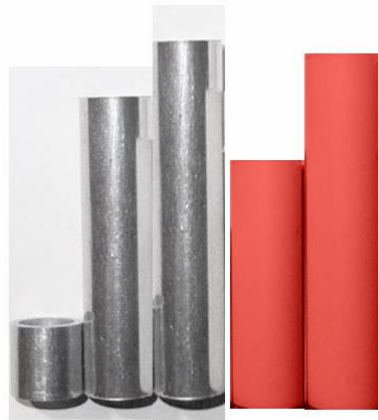

13.5mm 50mm 60mm 40mm 60mm

a pettit jr Apr 26

Fabrication Details

Assemble Antenna Array

Use the Lamp Tubing Kit Threaded Rod for Reflector, Feed, 1st Director then transition to the 36" Oak wood dowel for the balance of Directors.

>> Add a bit of weather resistance, **Spray Paint** the Wood Dowel

Shim first **Aluminum** and last **PEX Spacer** to keep them from sliding off the rods

(Use disposable pie tin aluminum / heavy tape / even hot glue if everything is exactly okay)

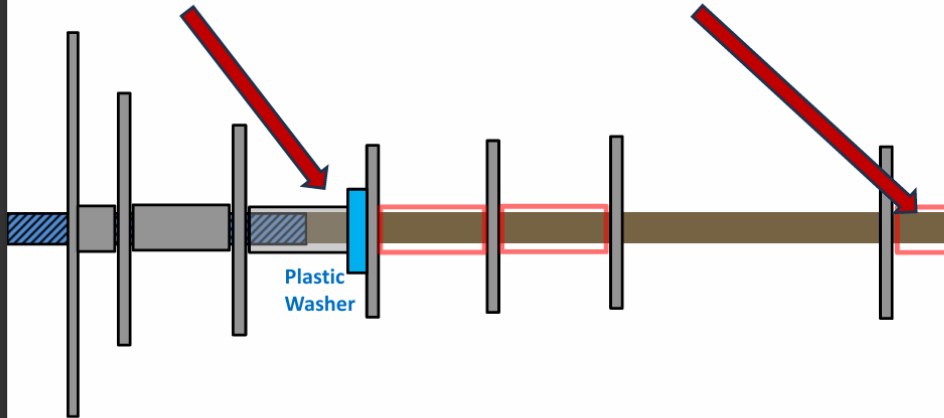

a petit jr Apr 26

Fabrication Details

Aluminum Spacers

It is important that good physical and electrical contact exist between each Disk and Spacer

The goal is to have smooth right angles on each Spacer end.

Saw Carefully, Clean Disks & Spacers, Assemble.

Use 2 wrenches to tighten the nuts and compress these 5 components.

(The lock washer between the two flat washers is intended to create a spring to maintain good compression over temperature changes)

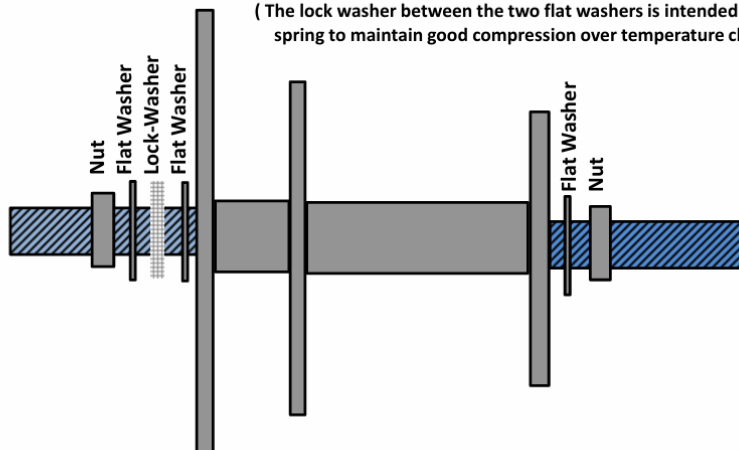

a petit jr Apr 26

Fabrication Details

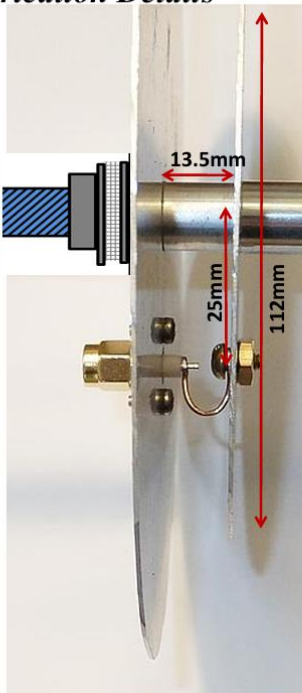

Patch Feed Construction Details

>> Most Critical Dimensions <<

- 112 mm Diameter of the patch feed
- 13.5 mm spacer Thickness reflector<->patch feed
- 25 mm Radius of the Feed Point

(copper wire loop on the SMA center conductor pin
Should Be Soldered
after SMA connector is installed on Reflector Disk)

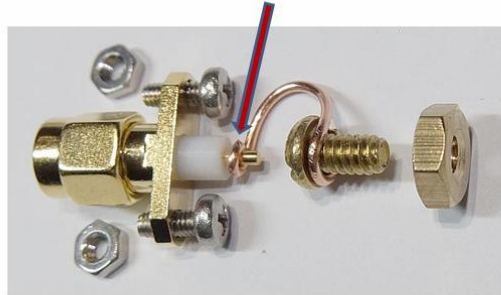

>> Clean Parts for good Electrical Contact <<

a petit jr Aug24

Fabrication Details

Shim first Aluminum and last PEX Spacer to keep them from sliding off the rods
(Use disposable pie tin aluminum / heavy tape / even hot glue if everything is exactly okay)

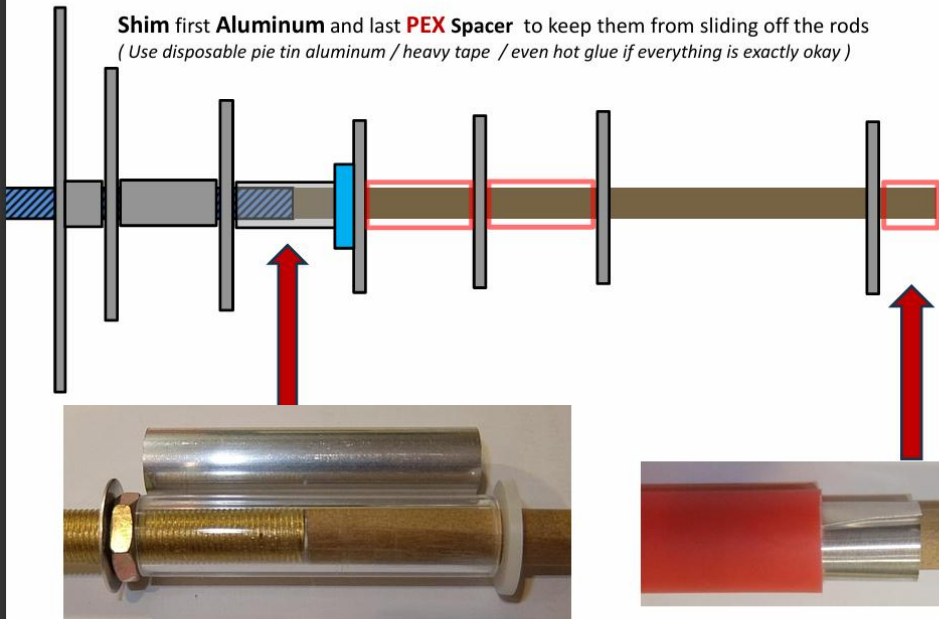

a petit jr Apr 26

Cir Patch Feed Disk Yagi Overall View & Tuning Plots

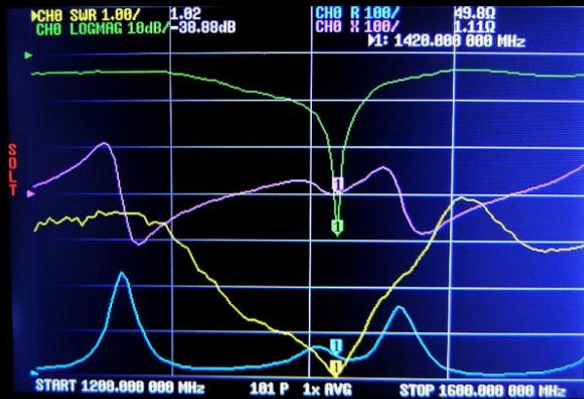
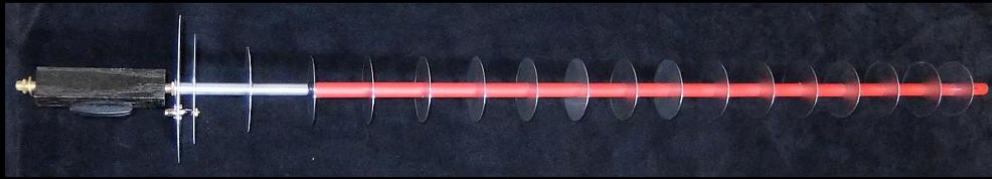

Cir Patch Feed Disk Yagi Dimensions for SE Enhanced Rel

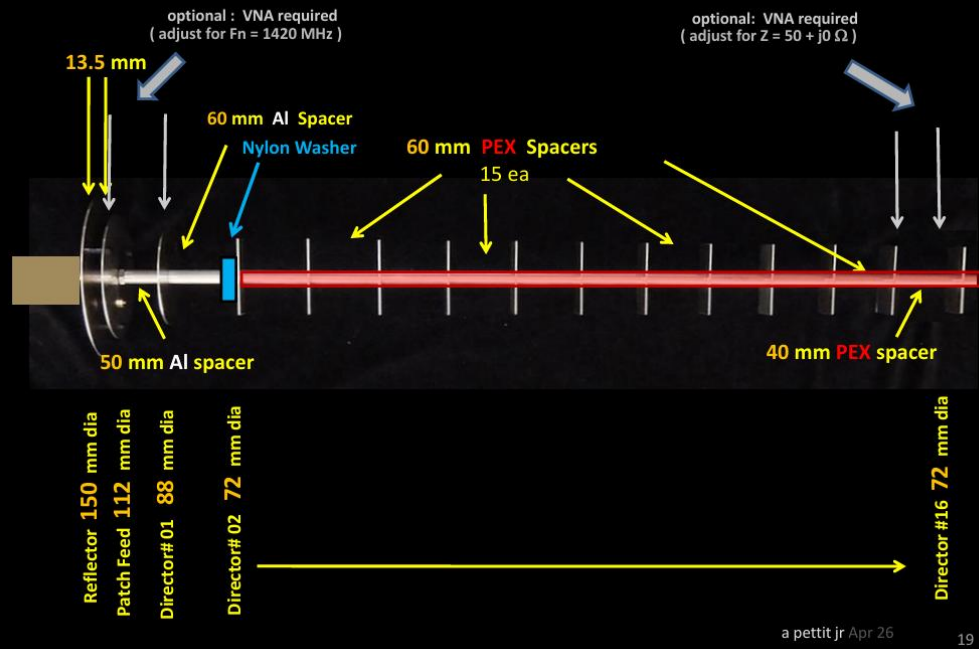

Interface Ideas
low cost lightweight Tripod



JOILCAN Tripod for Camera, Camera Tripod 67" Heavy Duty Tripod, Phone Tripod for Video Recording Photo Vlog, Aluminum Camera Tripods with Holder & Travel Bag for Camera DSLR iPhone Projector Laser

Visit the JOILCAN Store
4.5 ★★★★★ 1,580 ratings
| Search this page
300+ bought in past month

Roll over image to zoom in

-24% \$27⁹⁹

a Pettit jr Aug24

**Cir Patch Feed Disk
Yagi
Student Edition
Mounting Options**

LNA (low noise amplifier) Installation :
optimal orientation is for the feed point to be East-West

LNA : INPUT
signal
from
antenna

LNA : OUTPUT
amplified signal
to
coaxial cable

(other end of
cable connects to
SDR
software defined radio)

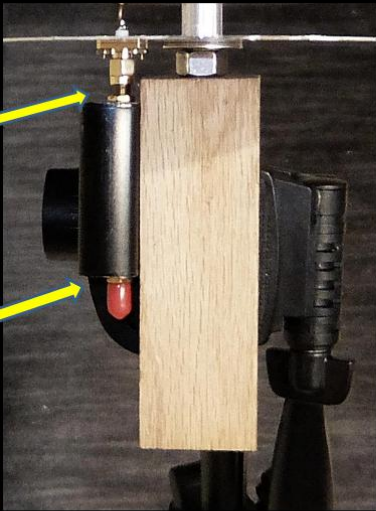

a pettit jr Aug24



a pettit jr Aug24

System Hardware and Software

Hardware & Software System Block Diagram

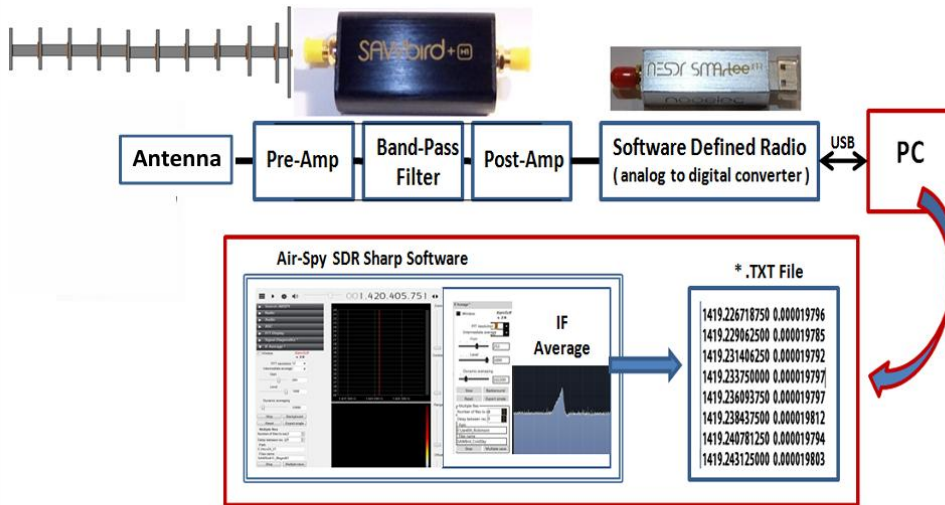

26

**** Improving Weather Resistance ****

Overnight Dew Shield : use a plastic polyethylene container



25

a pettit jr Aug24

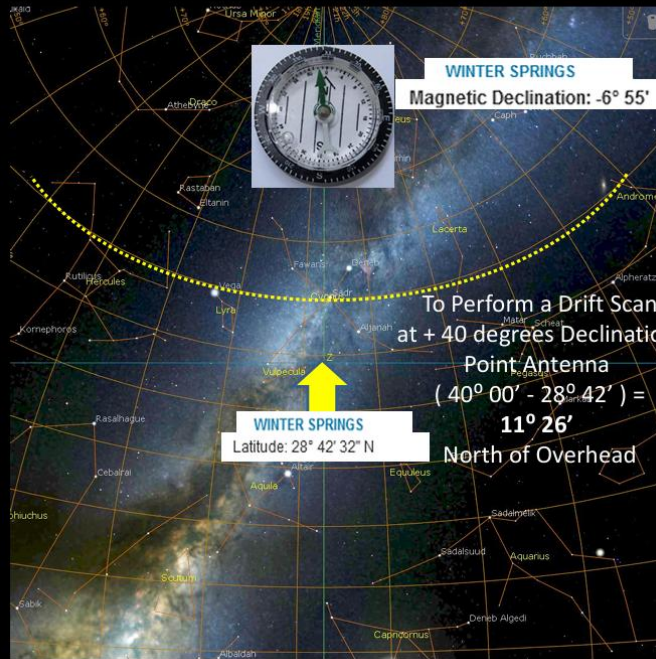

Stellarium Planetary Software

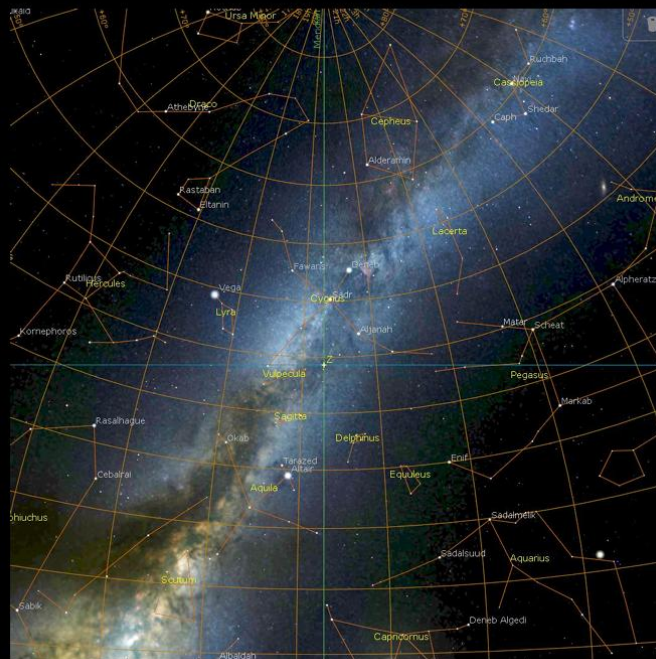

Signal Acquisition Software AirSpy SDR# Studio & Kaminski IF_Ave Plugin software

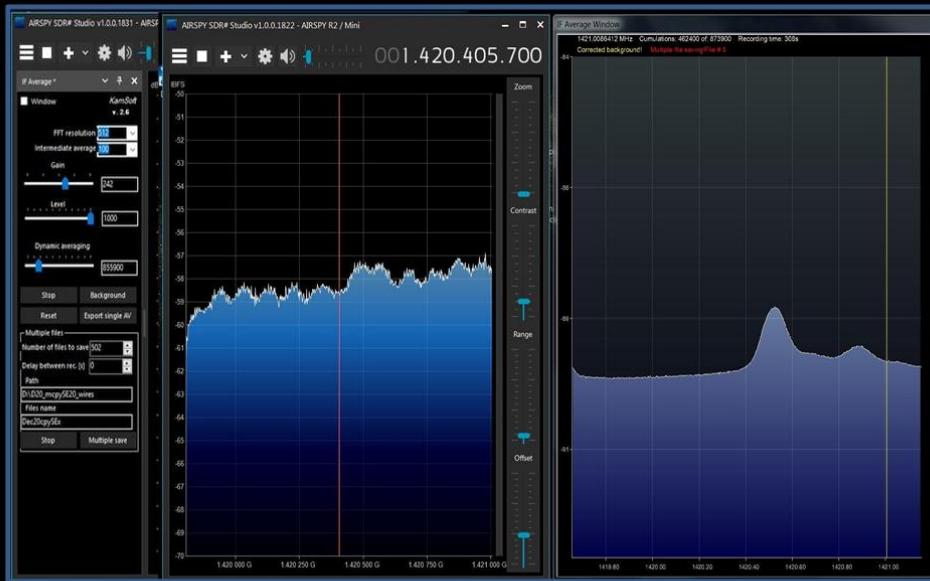

To Perform a Drift Scan
at + 40 degrees Declination,
Point Antenna
(40° 00' - 28° 42') =
11° 26' towards
North of Overhead



Perform a Drift Scan and Save a Data File Set

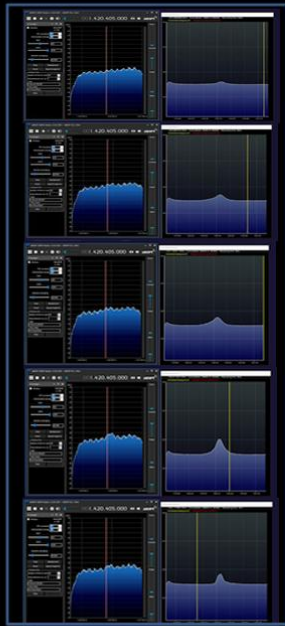

Dec40_cpy_SE01_0001.txt	8/18/2024 11:31 A...	Text Document	15 KB
Dec40_cpy_SE01_0002.txt	8/18/2024 11:36 A...	Text Document	15 KB
Dec40_cpy_SE01_0003.txt	8/18/2024 11:41 A...	Text Document	15 KB
Dec40_cpy_SE01_0004.txt	8/18/2024 11:46 A...	Text Document	15 KB
Dec40_cpy_SE01_0005.txt	8/18/2024 11:50 A...	Text Document	15 KB
Dec40_cpy_SE01_0006.txt	8/18/2024 11:55 A...	Text Document	15 KB
Dec40_cpy_SE01_0007.txt	8/18/2024 12:00 PM	Text Document	15 KB
Dec40_cpy_SE01_0008.txt	8/18/2024 12:05 PM	Text Document	15 KB
Dec40_cpy_SE01_0009.txt	8/18/2024 12:10 PM	Text Document	15 KB
Dec40_cpy_SE01_0010.txt	8/18/2024 12:15 PM	Text Document	15 KB
Dec40_cpy_SE01_0011.txt	8/18/2024 12:20 PM	Text Document	15 KB
Dec40_cpy_SE01_0012.txt	8/18/2024 12:24 PM	Text Document	15 KB
Dec40_cpy_SE01_0013.txt	8/18/2024 12:29 PM	Text Document	15 KB
Dec40_cpy_SE01_0014.txt	8/18/2024 12:34 PM	Text Document	15 KB
Dec40_cpy_SE01_0015.txt	8/18/2024 12:39 PM	Text Document	15 KB
Dec40_cpy_SE01_0016.txt	8/18/2024 12:44 PM	Text Document	15 KB
Dec40_cpy_SE01_0017.txt	8/18/2024 12:49 PM	Text Document	15 KB
Dec40_cpy_SE01_0018.txt	8/18/2024 12:54 PM	Text Document	15 KB
Dec40_cpy_SE01_0019.txt	8/18/2024 12:59 PM	Text Document	15 KB
Dec40_cpy_SE01_0020.txt	8/18/2024 1:03 PM	Text Document	15 KB
Dec40_cpy_SE01_0021.txt	8/18/2024 1:08 PM	Text Document	15 KB
Dec40_cpy_SE01_0022.txt	8/18/2024 1:13 PM	Text Document	15 KB
Dec40_cpy_SE01_0023.txt	8/18/2024 1:18 PM	Text Document	15 KB

System Operational Verification Hot_Earth vs Cold_Sky

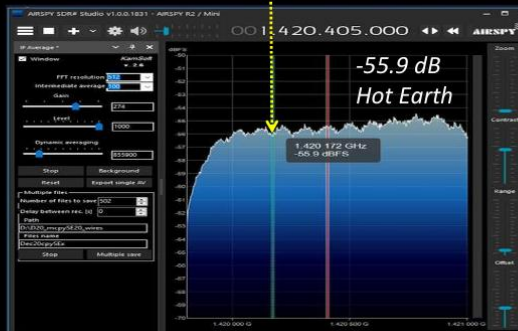
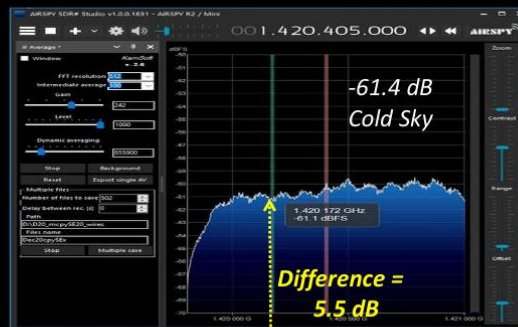

Reference Chart MW neutral hydrogen distribution

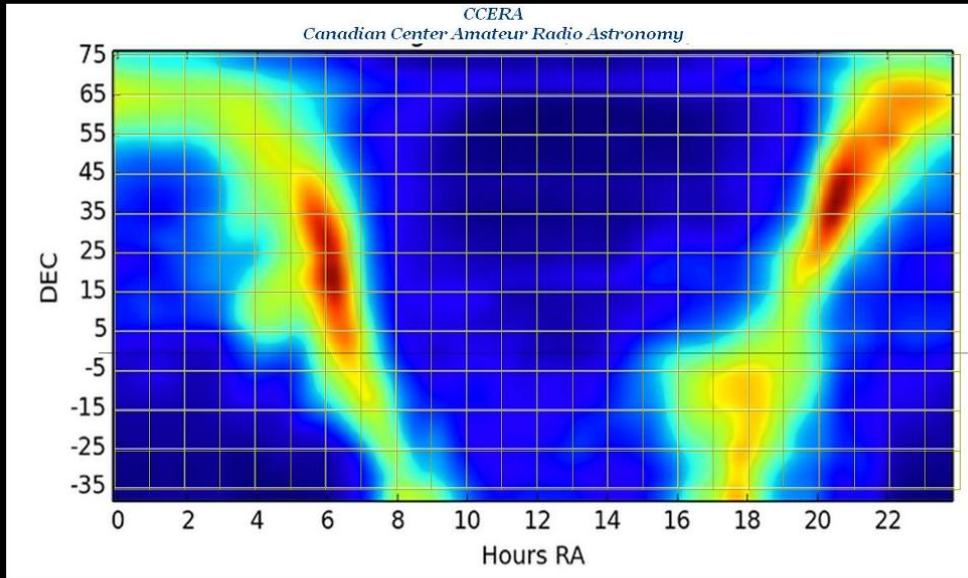

a Pettit Jr Aug24 34

Plot Data via Excel (Open Office Calc)

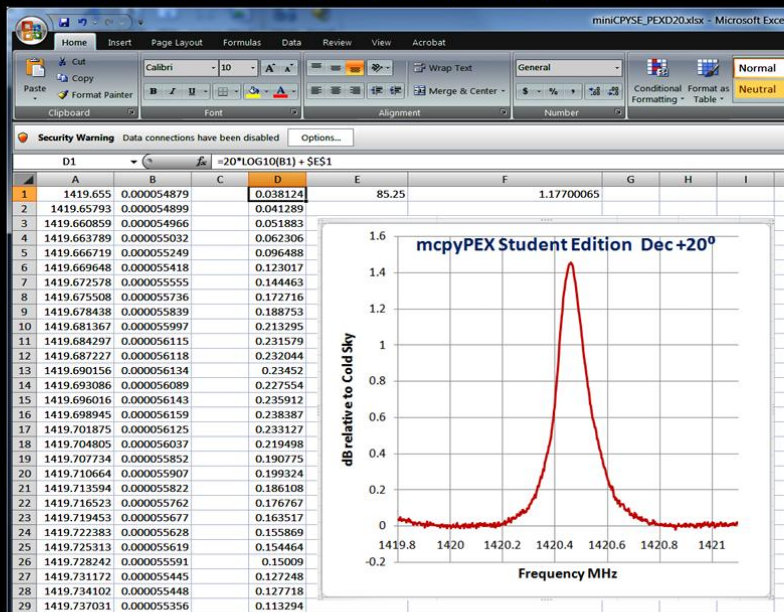

a Pettit Jr Aug24 33

Software

(HLine3D and Rinearn : Data Set Processing and 2D / 3D Graphics)

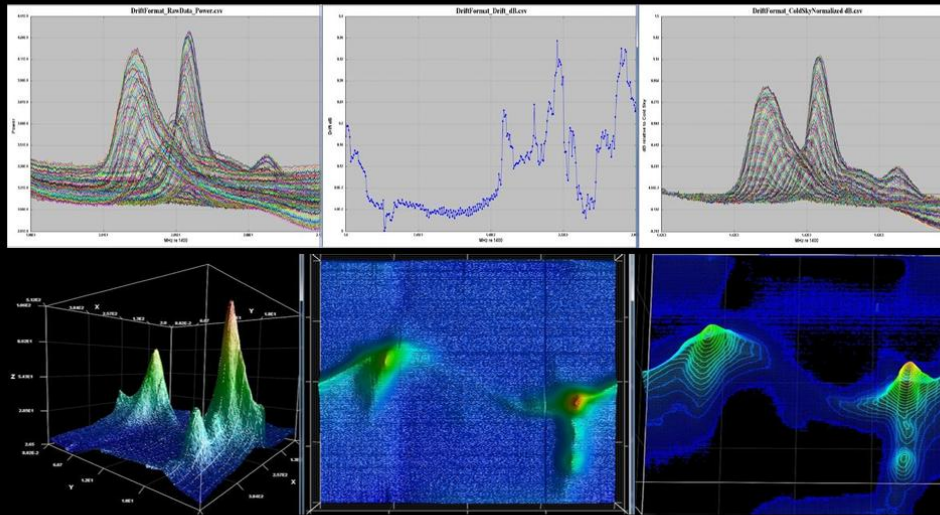

a Pettit jr Aug24 36

Software

AirSpy SDR# Studio and Kaminski IF_Ave plug-in

<https://www.dropbox.com/scl/fi/2f67lyu6qgt2cp98rg9kp/SDR-2.ZIP?rlkey=y82yv6jzjyu7e92sap3x8ewm7&st=tcil7w3s&dl=0>

Stellarium planetarium software

<https://stellarium.org>

(Excel or Apache Open Office Calc)

<https://www.openoffice.org/product/calc.html>

a Pettit jr Aug24 35

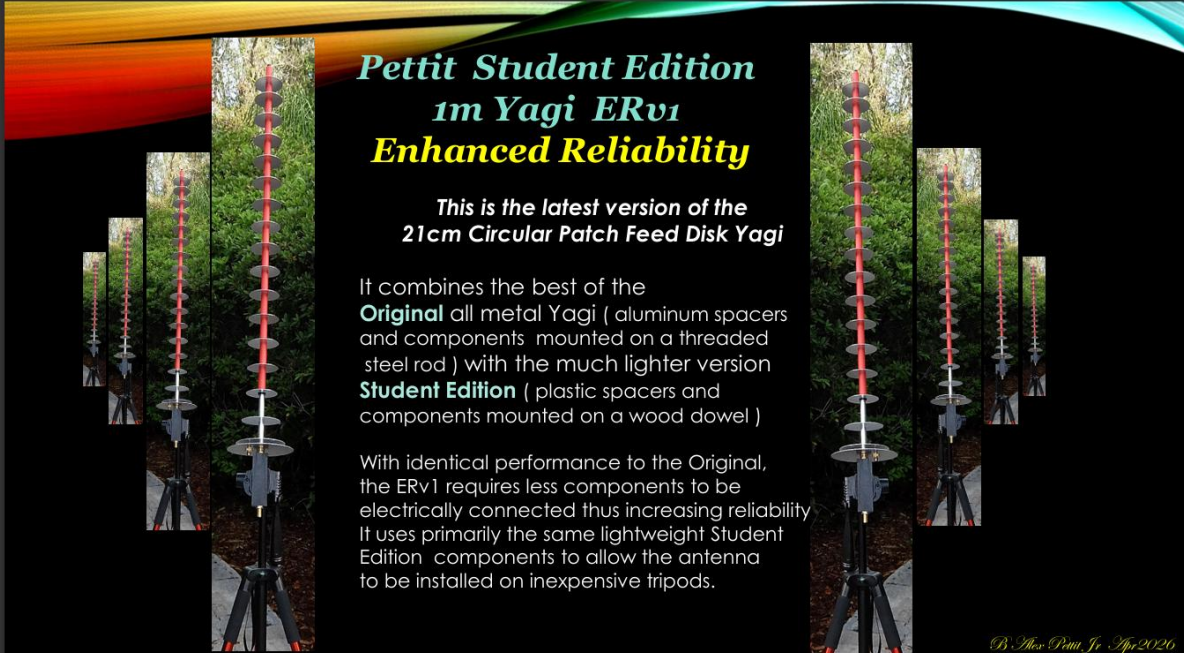

**Pettit Student Edition
1m Yagi ERv1
Enhanced Reliability**

*This is the latest version of the
21cm Circular Patch Feed Disk Yagi*

It combines the best of the **Original** all metal Yagi (aluminum spacers and components mounted on a threaded steel rod) with the much lighter version **Student Edition** (plastic spacers and components mounted on a wood dowel)

With identical performance to the Original, the ERv1 requires less components to be electrically connected thus increasing reliability. It uses primarily the same lightweight Student Edition components to allow the antenna to be installed on inexpensive tripods.

B. Alex Pettit Jr. Apr 2026



**Pettit Student Edition
1m Yagi ERv1
Enhanced Reliability**

Results & Performance Comparison

Petit Student Edition 1m Yagi ER Version 1

VS

Kraken Discovery Dish & H1 Feed

The Kraken Discovery Dish H1 System is the highest performing Near-Off-The-Shelf H Line Radio Telescopes I've evaluated. So it made a good system for reference

https://github.com/AP-HLine-3D/HLine3D/blob/main/21cm_Step1b_KrakenDiscoveryFeed_Eval_05.pdf

Petit Student Edition
1m Yagi ERv1
Enhanced Reliability

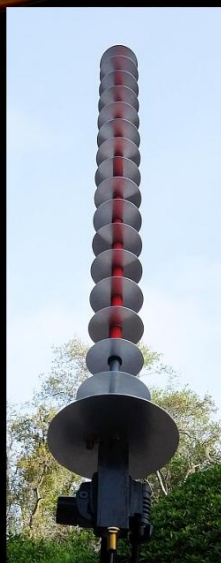

Kraken Discovery Feed 1420 MHz
w/ 1m x 0.66m Dish



B. Alex Pettit Jr Dec 2025

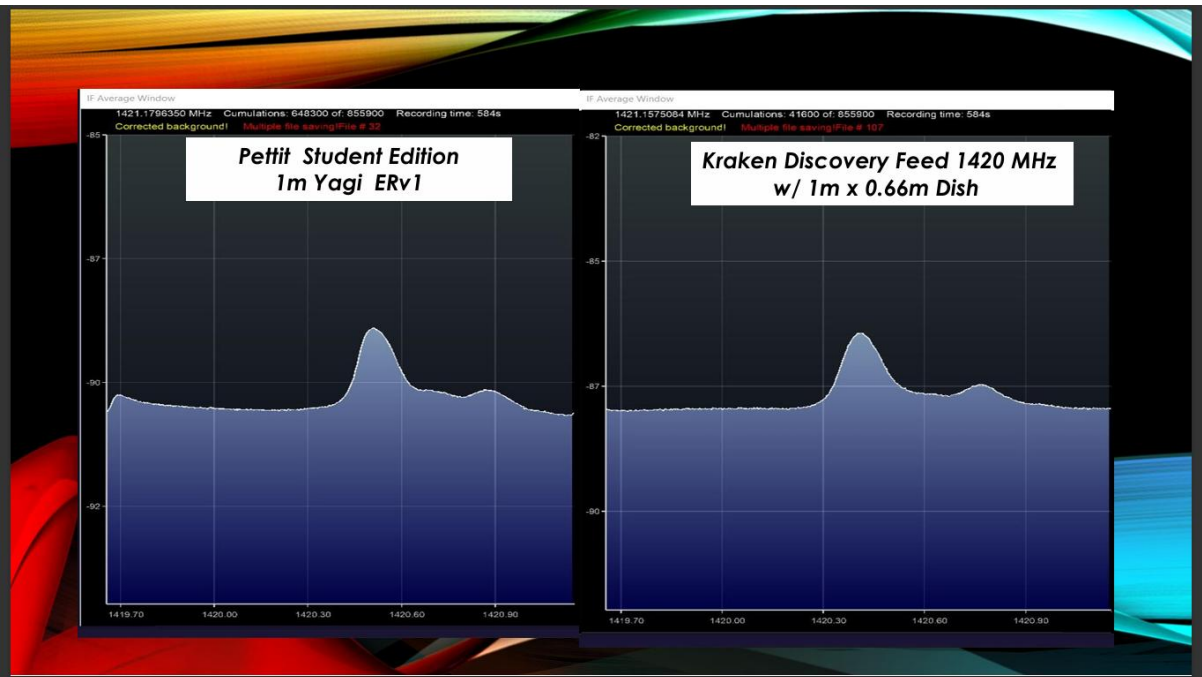
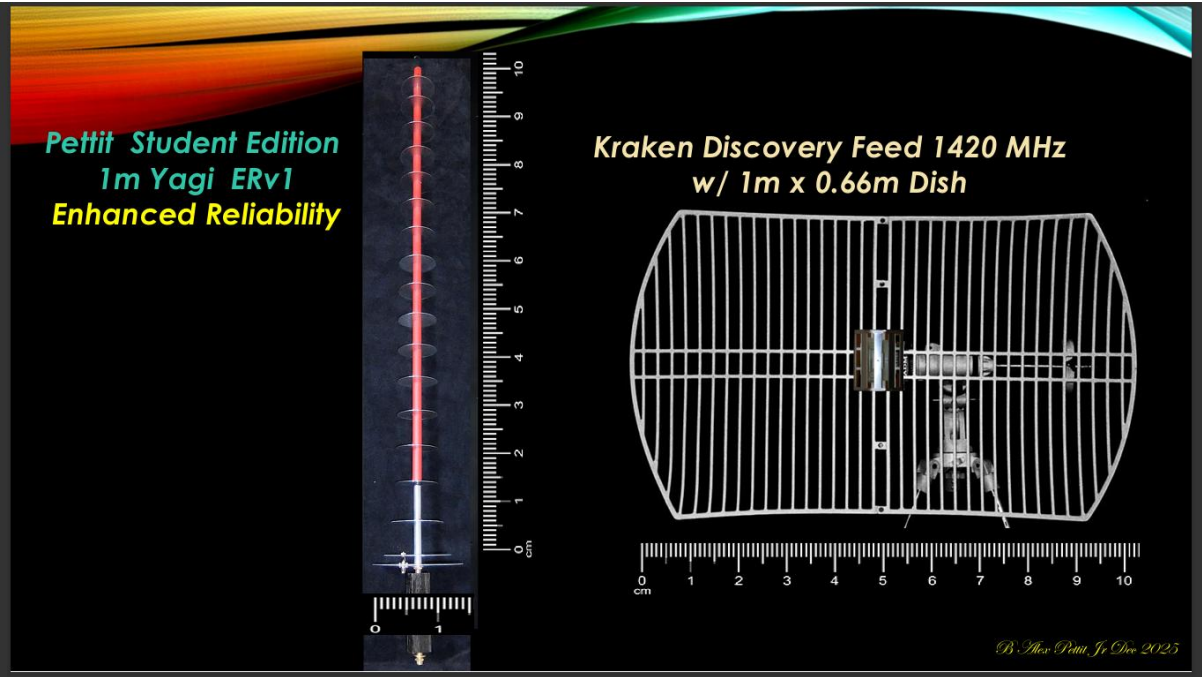

Due to its larger size, a 1m dia parabolic dish creates a beamwidth of 12 degrees vs 28 degrees for the smaller Yagi .
 It improves the Angular Resolution of the Hydrogen distribution
 But the Signal Strengths are quite similar.

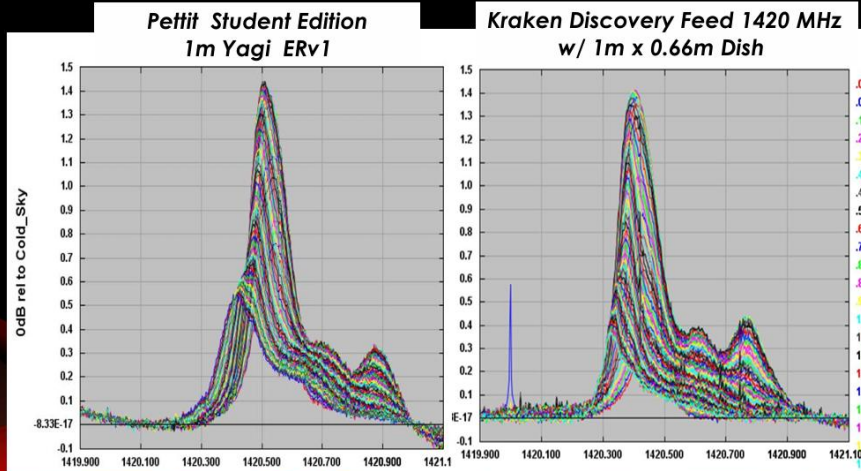

Due to its larger size, a 1m dia parabolic dish creates a beamwidth of 12 degrees vs 28 degrees for the smaller Yagi .
 It improves the Angular Resolution of the Hydrogen distribution
 But the signal strengths are quite similar.

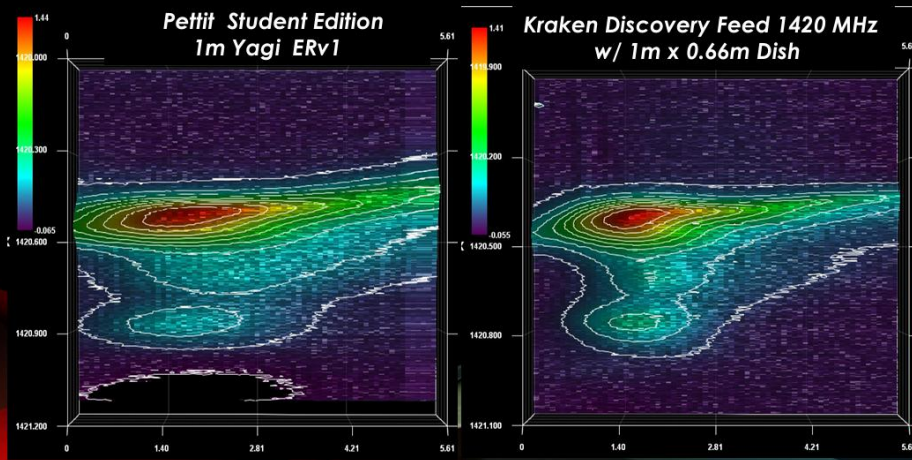

Petit Student Edition
1m Yagi ERv1

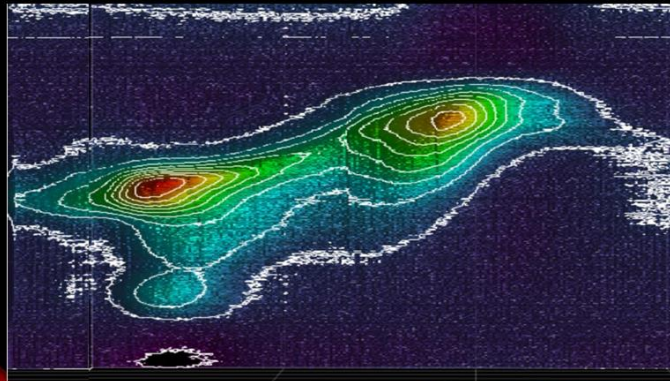

Antenna Tuning Performance

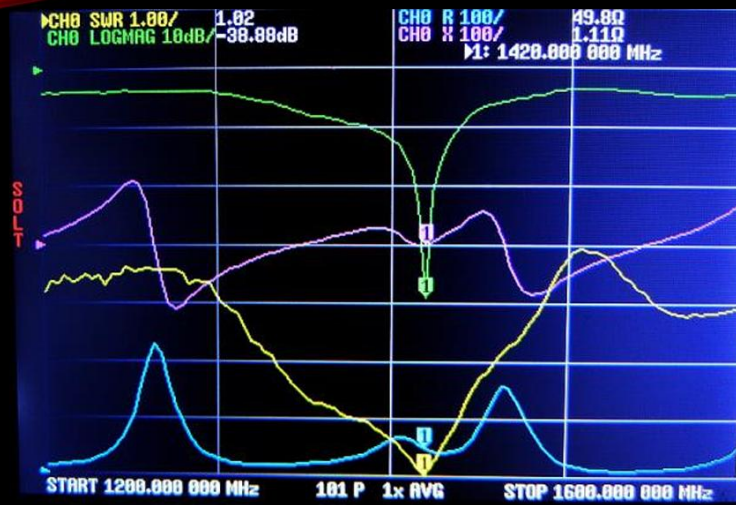

Brief Report on First Light Observations with 134cm VLF Antenna.

Dr Andrew Martyn Thornett.

Lichfield Radio Observatory.

www.astronomy.me.uk

Abstract

Very Low Frequency (VLF; 15–40 kHz) radio monitoring remains one of the most accessible and educationally valuable branches of amateur radio astronomy, particularly for observing ionospheric perturbations caused by solar flares and other space weather phenomena. Established systems such as the SuperSID receiver and the UK Radio Astronomy Association (UKRAA) VLF receiver provide structured approaches to data collection using small loop antennas. This brief report describes the construction and first-light observations of a passive 134 cm loop antenna connected directly to a USB computer sound card without intermediate amplification. Despite its simplicity and minimal cost, the system demonstrated effective broadband reception of multiple VLF transmitters and ionospheric signatures, comparable in qualitative performance to amplified systems. The results suggest that direct-to-sound-card VLF monitoring can offer a viable low-cost alternative for introductory and experimental work within the amateur radio astronomy community.

Materials and Methods

Antenna Construction

The antenna consists of a 134 cm square wooden cross-frame wound with enameled 22 SWG copper wire around its perimeter. The loop was constructed indoors and dimensioned to allow passage through a standard doorway.

A 10 μ F capacitor was inserted in series with one conductor to provide AC coupling and prevent sound-card input suppression due to DC short detection.

Figure 1. Mechanical Construction of the 134 cm VLF Loop



Photograph of the 134 cm square loop antenna showing wooden cross-frame support and perimeter winding. The loop is constructed from enameled copper wire wound around the

outer edges of the frame. The feed point is taken from one corner, with a 10 μ F capacitor inserted in series before connection to the computer sound card input.

Receiver Configuration

Initial testing with an internal sound card proved unreliable. An external USB sound card capable of 96 kHz sampling was substituted, increasing usable bandwidth and improving stability. No active amplification or tuning stage was used.

Figure 2. System Block Diagram.

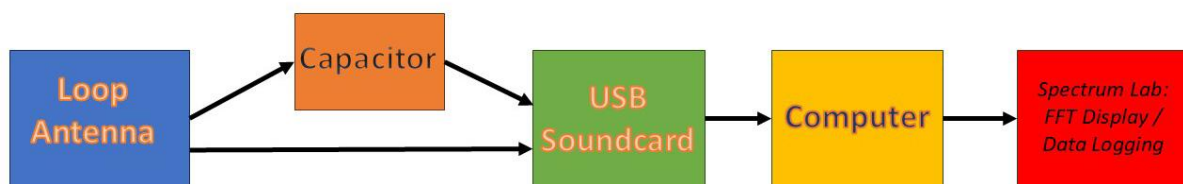

Block diagram of the passive VLF monitoring system. The loop antenna feeds directly to the computer sound card via a series coupling capacitor. The sound card digitizes the signal (96 kHz sampling), and FFT-based spectrum analysis software provides real-time spectral display and logging. No preamplifier or tuned front end is included.

Setting up stations on Spectrum Spectrum-Analyzer Software.

In Spectrum Lab, an offset can be applied to each station to separate the stations along the Y-axis and interpretation easier.

Figure 2A: Spectrum Lab Output Example

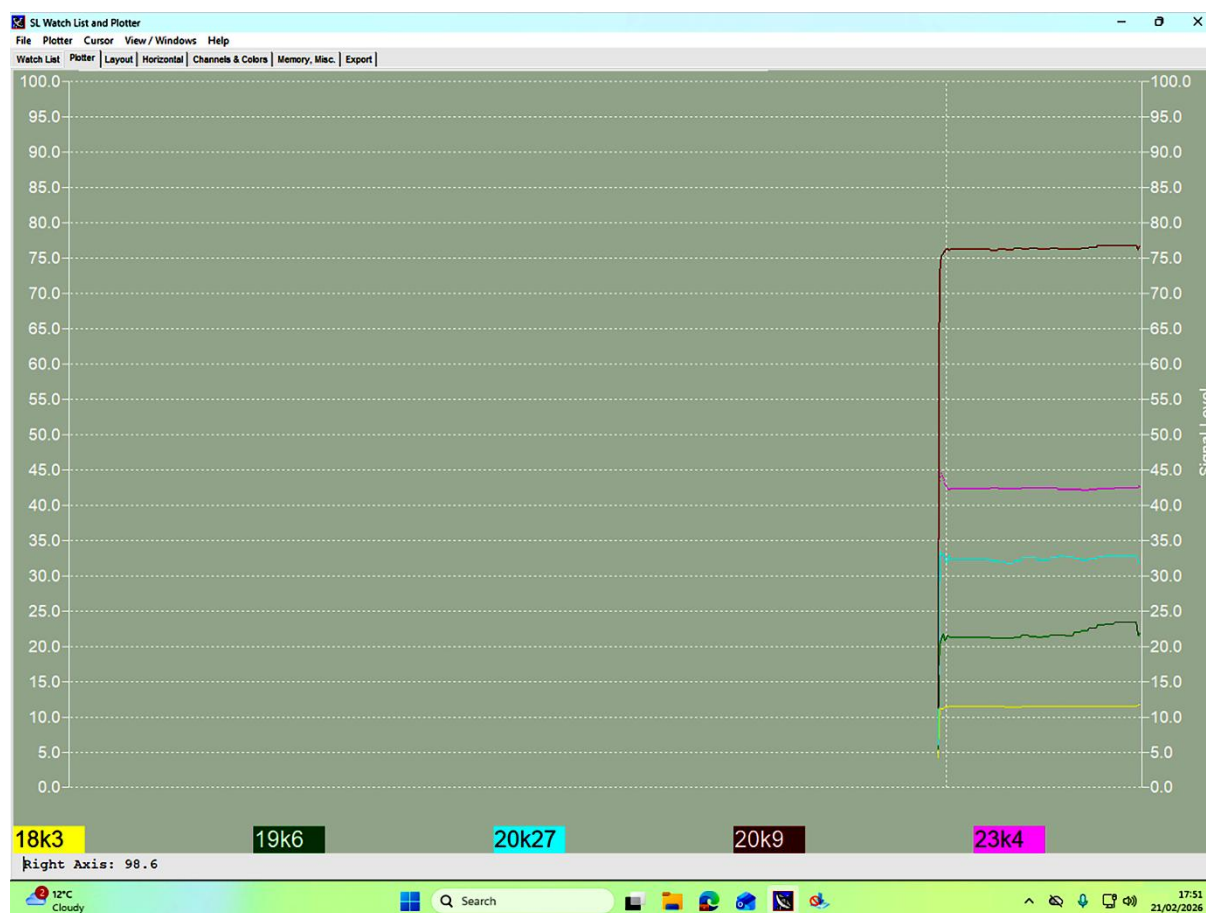

Results

The passive 134 cm loop successfully detected multiple VLF transmitters simultaneously within the 15–40 kHz band. Signal amplitudes were sufficient for stable identification in FFT spectral displays.

Diurnal variation consistent with ionospheric D-layer changes was observed. Signal strength variations were comparable in clarity to those obtained using amplified systems.

Figure 3. Plots of first light broadband detection of Sudden Ionospheric Disturbances (SIDs) 25 February 2026.

First light success was achieved 25 February 2026 at Lichfield Radio Observatory, using the 134 cm passive loop and 96 kHz USB sound card. Multiple discrete VLF transmitter carriers

were visible simultaneously. Signal stability and signal-to-noise ratio were sufficient for continuous monitoring without additional amplification.

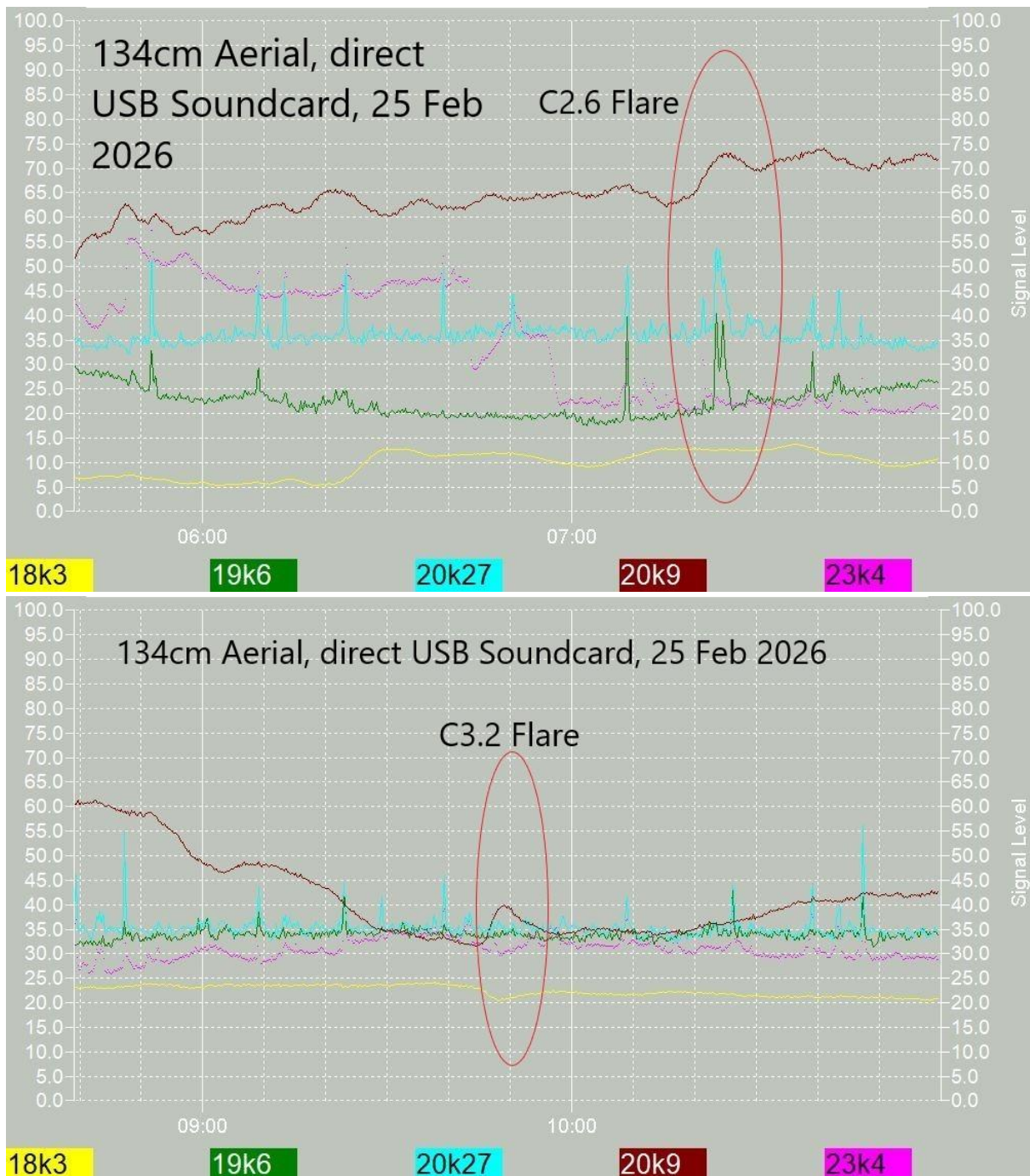

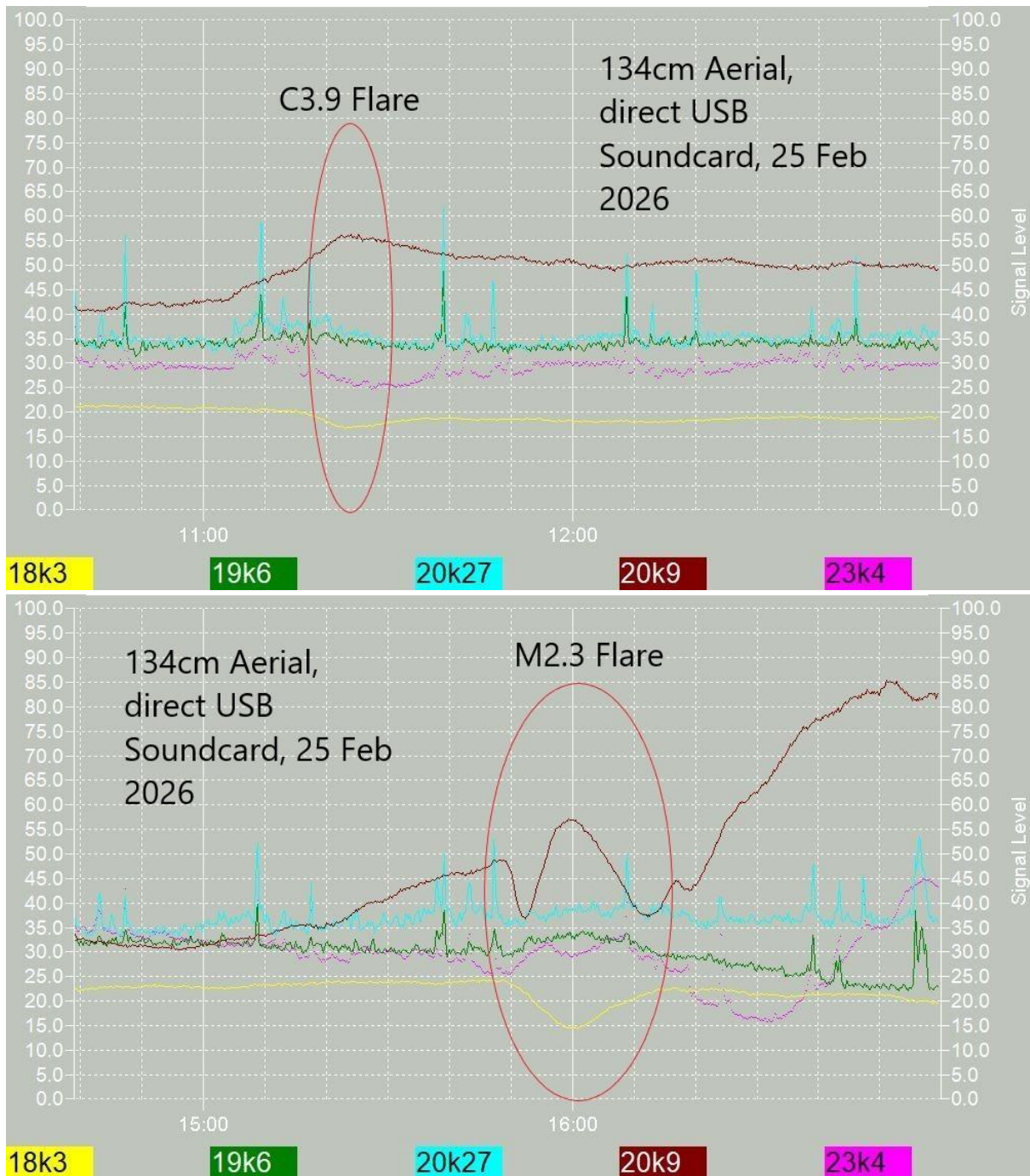
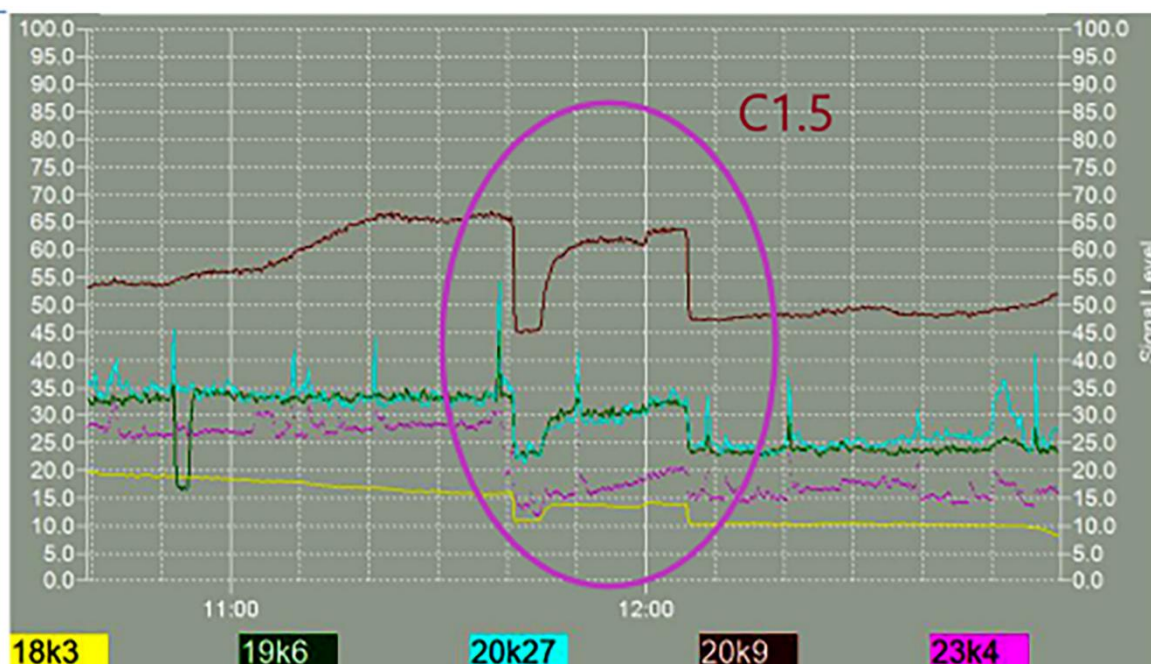
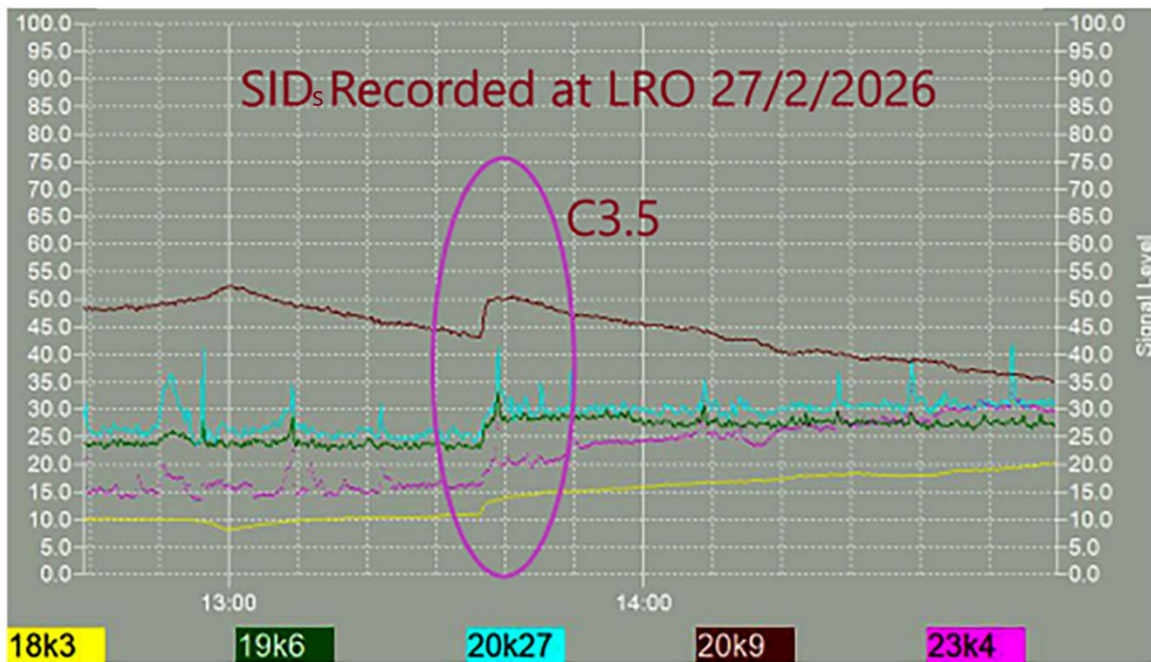

Figure 4. Plots of broadband detection of Sudden Ionospheric Disturbances (SIDs) 27 February 2026.

Further successful detection of SIDs occurred 27 February 2026. Results are compared to a whole-day plot from the UKRAA 70cm antenna and receiver at LRO. This latter plot shows a time-series plot of received VLF signal amplitude from the selected 23.4 kHz transmitter over

a 24-hour period. Change in daytime vs. nighttime signal amplitude is consistent with increased D-layer ionization, with recovery after sunset. Data recorded using passive loop with tuning receiver.

The above plots are then compared to results from 27 February at Lionel Loudet's SID Monitoring Station (<https://sidstation.loudet.org/data-en.xhtml>), where solar flares detected by GOES Satellites have been annotated (parallel lines).



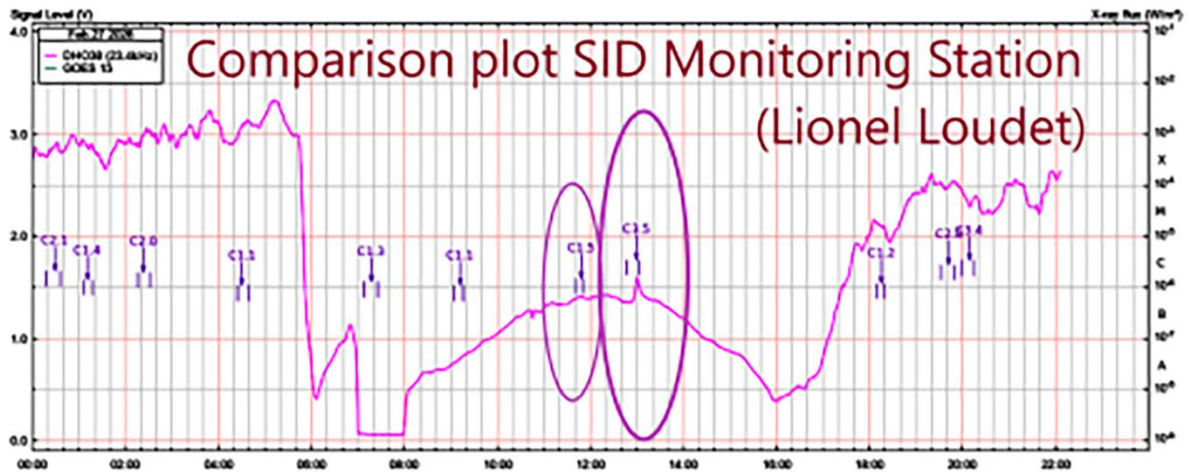
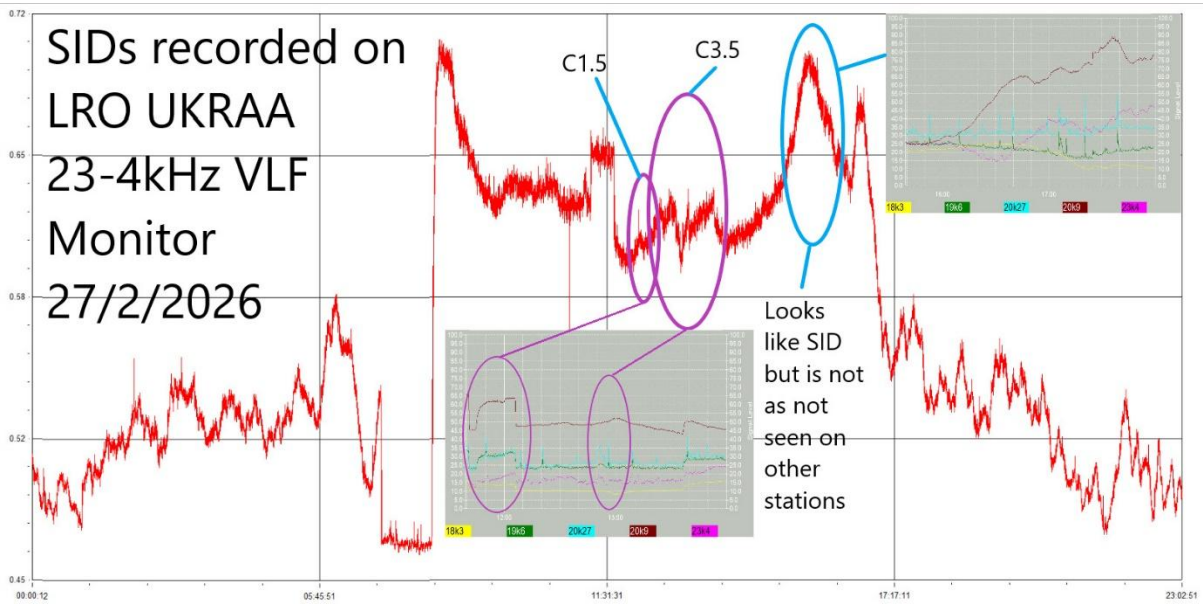

Discussion

The unexpectedly strong performance of the passive loop likely results from increased loop area relative to smaller educational designs, combined with the adequate sensitivity of modern USB sound interfaces.

The broadband configuration permits simultaneous monitoring of multiple transmitters, retaining one of the principal advantages of systems such as SuperSID while eliminating the need for dedicated amplification hardware.

Future work should include:

- Quantitative signal-to-noise comparison with amplified loops
- Controlled measurements during solar flare events
- Noise-floor comparison in indoor versus outdoor deployment

Conclusion

First-light testing of a 134 cm passive VLF loop antenna connected directly to a 96 kHz USB sound card demonstrates that amplification or tuning to a single station is not strictly required for effective VLF monitoring under favorable conditions.

This configuration offers a low-cost, low-complexity alternative for amateur radio astronomers and educational groups wishing to experiment with broadband VLF ionospheric observations.

Journal Archives and Other Promotions

The rich and diverse legacy of member contributed content is available in the SARA Journal Archives. Table of contents for journals is available online at: [SARA-Journal-Master-Index.xlsx \(live.com\)](#)

The entire set of The Journal of The Society of Amateur Radio Astronomers is available by online download. It goes from the beginning of 1981 to the present (over 6000 pages of SARA history!)

All SARA journals and conference proceedings are available through the previous calendar year.

SARA Store (radio-astronomy.org/store.)

SARA Online Discussion Group

SARA members participate in the online forum at <http://groups.google.com/group/sara-list>. This is an invaluable resource for any amateur radio astronomer.

SARA Conferences

SARA organizes multiple conferences each year. Participants give talks, share ideas, attend seminars, and get hands-on experience. For more information, visit <http://www.radio-astronomy.org/meetings>.

What is Radio Astronomy?

Radio Astronomy is just what the name implies.... Astronomy observed at radio wavelengths instead of optical. But why do radio astronomy? Radio astronomy has expanded the knowledge of the universe about as much since its discovery in 1932 as optical has since humans first looked up at the sky. (The sky in the different frequencies or colors of radio are as different and varied as all of the flowers on Earth. Each frequency has its own information about what is happening in the universe.) This knowledge has been gained by both professional astronomers as well as amateurs, with amateurs contributing to this day.

Do I need a big dish and expensive equipment?

No. Complete beginner projects are available at the [SARA store](#) at very reasonable prices. You can monitor the Sun's effects upon our planet with [SuperSID](#). This information is gathered for Stanford for research into our ionosphere and radio signal propagation. Another project is the detection the hydrogen line just like Dr. Ewen had done in 1951 for a fraction of the cost using the [Scope in a Box](#) kit.

That said, radio astronomy is like optical astronomy in that you can spend as much as you want to. Many amateurs push the lower boundaries of cost by using very low-cost receivers and low-noise low-cost amplifiers that were not available even a few years ago. (See the [Scope in a Box](#) kit in the store for examples of both.)

Is everything 'plug and play' and boring?

The kits mentioned above are a starting point which are mostly plug-and-play... that gets you started. After you have mastered the basics, where you go from there depends upon your interests. Monitoring pulsars is done by amateurs. (One even noticed a [pulsar glitch](#) before the professionals!) These amateurs are pushing the boundaries of what can be done. Papers are being published and discussions had about pulsar detection as well detection of a MASER with a 50-inch dish. Techniques on new detection methods are posted in the [SARA forum](#) and elsewhere. You are free to build your own equipment to receive the signals as well as software to collect and analyze the data.

What is SETI?

SETI is the Search for Extra-Terrestrial Intelligence. Some amateurs scan the sky and search for signals that might be from aliens. To date no one has received a definitive alien signal (professional or amateur), but the search continues. The search has resulted not just in better receiving equipment but also wide and lively discussions about how aliens might communicate and how they might be trying to contact us. Some of these techniques have interesting ideas for our own communication techniques here on Earth!

What should I do to get started?

You should start with reading our [Introduction to Radio Astronomy](#) and joining our online [SARA Forum](#). Look at the [SARA store](#) to get a project to get your feet wet without much expense and minimal risk. We will work with you so you can succeed.

Administrative

Officers, directors, and additional SARA contacts

The Society of Amateur Radio Astronomers is an all-volunteer organization. The best way to reach people on this page is by email with SARA in the subject line SARA Officers.

President: Dr. Rich Russel, AC0UB, <https://www.radio-astronomy.org/contact/President>

Vice President: Marcus Fisher, <https://www.radio-astronomy.org/contact/Vicepresident>

Secretary: Brian O'Rourke, <https://www.radio-astronomy.org/contact/Secretary>

Treasurer: Tom Jacobs, <https://www.radio-astronomy.org/contact/Treasurer>

Past President: Dennis Farr (Acting Treasurer)

Founder Emeritus and Director: Jeffrey M. Lichtman, KI4GIY, jeff@radioastronomysupplies.com

Board of Directors

Name	Term expires	Email
Ted Cline	2027	TedClineGit@gmail.com
Dennis Farr	2026	dennisfarr@verizon.net
Ed Harfmann	2027	edharfmann@comcast.net
Dr. Wolfgang Herrmann	2027	messbetrieb@astropeiler.de
Don Latham	2026	djl@montana.com
Bruce Randall	2027	brandall@comporium.net
Steve Tzikas	2026	Tzikas@alum.rpi.edu
Jay Wilson	2026	jwilson@radio-astronomy.org

Other SARA Contacts

All Officers	http://www.radio-astronomy.org/contact-sara
All Directors and Officers	http://www.radio-astronomy.org/contact/All-Directors-and-Officers
Eastern Conference Coordinator	http://www.radio-astronomy.org/contact/Annual-Meeting
All Radio Astronomy Editors	http://www.radio-astronomy.org/contact/Newsletter-Editor

Radio Astronomy Editor and YouTube Producer	Dr. Richard A. Russel	drrichrussel@radio-astronomy.org
Contributing Editor	Bogdan Vacaliuc	bvaculiuc@iee.org
Educational Co-Chairs	Ken Redcap, Tom Hagen: http://www.radio-astronomy.org/contact/Educational-Outreach	
Grant Committee	Tom Crowley	grants@radio-astronomy.org
Membership Chair	http://www.radio-astronomy.org/contact/Membership-Chair	
Technical Queries (David Westman)	http://www.radio-astronomy.org/contact/Technical-Queries	
Webmaster	Ciprian (Chip) Sufitchi, N2YO	webmaster@radio-astronomy.org

Resources

Great Projects to Get Started in Radio Astronomy

Radio Observing Program

The Astronomical League (AL) is starting a radio astronomy observing program. If you observe one category, you get a Bronze certificate. Silver pin is two categories with one being personally built. Gold pin level is at least four categories. (Silver and Gold level require AL membership which many clubs have membership. For the bronze level, you need not be a member of AL.)

Categories include.

- 1) SID
- 2) Sun (aka IBT)
- 3) Jupiter (aka Radio Jove)
- 4) Meteor back-scatter
- 5) Galactic radio sources

This program is a collaboration between NRAO and AL. Steve Boerner is the Lead Coordinator and a SARA member.

For more information:

Steve Boerner

2017 Lake Clay Drive

Chesterfield, MO 63017

Email: sboerner@charter.net

Phone: 636-537-2495

<http://www.astroleague.org/programs/radio-astronomy-observing-program>

Radio Jove



The Radio Jove Project monitors the storms of Jupiter, solar activity and the galactic background. The radio telescope can be purchased as a kit, or you can order it assembled. They have a terrific user group you can join. <http://radiojove.gsfc.nasa.gov/>

INSPIRE Program



The INSPIRE program uses build-it-yourself radio telescope kits to measure and record VLF emissions such as tweeks, whistlers, sferics, and chorus along with man-made emissions. This is a very portable unit that can be easily transported to remote sites for observations.

<http://theinspireproject.org/default.asp?contentID=27>

SARA/Stanford SuperSID



Stanford Solar Center and the Society of Amateur Radio Astronomers have teamed up to produce and distribute the SuperSID (Sudden Ionospheric Disturbance) monitor. The monitor utilizes a simple pre-amp to magnify the VLF radio signals which are then fed into a high-definition sound card. This design allows the user to monitor and record multiple frequencies simultaneously. The unit uses a compact 1-meter loop antenna that can be used indoors or outside. This is an ideal project for the radio astronomer that has limited space. To request a unit, send an e-mail to

supersid@radio-astronomy.org

Radio Astronomy Online Resources

SARA YouTube Videos: https://www.youtube.com/@radio-astronomy	Pisgah Astronomical Research Institute: www.pari.edu
AJ4CO Observatory – Radio Astronomy Website: http://www.aj4co.org/	A New Radio Telescope for Mexico - ORION 2021 01 20. Dr. Stan Kurtz https://www.youtube.com/watch?v=Q9aBWr1aBVc
Radio Astronomy calculators https://www.aj4co.org/Calculators/Calculators.html	National Radio Astronomy Observatory http://www.nrao.edu
Introduction to Amateur Radio Astronomy (presentation) http://www.aj4co.org/Publications/Intro%20to%20Amateur%20Radio%20Astronomy,%20Typinski%20(AAC,%202016)%20v2.pdf	Exotic Ions and Molecules in Interstellar Space -- ORION 2020 10 21. Dr. Bob Compton https://www.youtube.com/watch?v=r6cKhp23SUo&t=5s
RF Associates Richard Flagg, rf@hawaii.rr.com 1721-1 Young Street, Honolulu, HI 96826	The Radio JOVE Project & NASA Citizen Science – ORION 2020.6.17. Dr. Chuck Higgins https://www.youtube.com/watch?v=s6eWAXJywp8&t=5s
RFSpace, Inc. http://www.rfspace.com	UK Radio Astronomy Association: UK Radio Astronomy Association (UKRAA) - Home
CALLISTO Receiver & e-CALLISTO http://www.reeve.com/Solar/e-CALLISTO/e-callisto.htm	CALLISTO software and data archive: www.e-callisto.org
Deep Space Exploration Society http://DSES.science	Radio Jove Spectrograph Users Group http://www.radiojove.net/SUG/
Deep Space Object Astrophotography Part 1 -- ORION 2021 02 17. George Sradnov https://www.youtube.com/watch?v=Pm_Rs17KlyQ	Radio Sky Publishing http://radiosky.com
European Radio Astronomy Club http://www.eraonet.org	The Arecibo Radio Telescope; It's History, Collapse, and Future - ORION 2020.12.16. Dr. Stan Kurtz, Dr. David Fields https://www.youtube.com/watch?v=rBZlPOLNX9E
British Astronomical Association – Radio Astronomy Group http://www.britastro.org/baa/	Shirleys Bay Radio Astronomy Consortium marcus@propulsionpolymers.com
Forum and Discussion Group http://groups.google.com/group/sara-list	SARA Twitter feed https://twitter.com/RadioAstronomy1
GNU Radio https://www.gnuradio.org/	SARA Web Site http://radio-astronomy.org
SETI League http://www.setileague.org	Simple Aurora Monitor: Magnetometer http://www.reeve.com/SAMDescription.htm
NRAO Essential Radio Astronomy Course http://www.cv.nrao.edu/course/astr534/ERA.shtml	Stanford Solar Center http://solar-center.stanford.edu/SID/
NASA Radio JOVE Project http://radiojove.gsfc.nasa.gov Archive: http://radiojove.net/archive.html https://groups.io/g/radio-jove	https://www.csiro.au/ There's a wealth of info on this site of the Australian National Science Agency. It's much more than just radio astronomy. Looking under "Research" opens a real family tree of interesting pages of things they are involved with.
Green Bank Observatory https://greenbankobservatory.org/ .	

Found an interesting Grote Reber link: <https://www.utas.edu.au/groterebmuseum> Their gallery is interesting, but sure wish they had some captions to indicate who and what some of it is about. I can guess,

knowing some of Grote's stories, but others might need more info. Several pictures show the University of Tasmania 26m dish that was once one of the NASA worldwide Satellite Tracking and Data Network (STDN) dishes like the ones at the Pisgah Astronomical Research Institute (www.pari.edu). PARI's dishes were the first qualification units for that network.

For Sale, Trade and Wanted

At the SARA online store: radio-astronomy.org/store.

New on-demand store for SARA SWAG! <https://saragifts.org/>

Scope in a Box

radio-astronomy.org/store.

Kit of parts and software to build a working Radio Telescope to detect Hydrogen Line emissions. Available to USA addresses only at this time.

SuperSID Complete Kit

radio-astronomy.org/store.



SARA Publication, Journals and Conference Proceedings (various prices)

radio-astronomy.org/store.

SARA Journal Online Download

radio-astronomy.org/store.

The Journal archive covers the society journal "Radio Astronomy" from the founding of the organization in 1981 through the present. Articles cover a wide range of topics including cosmic radiation, pulsars, quasars, meteor detection, solar observing, Jupiter, Radio Jove, gamma ray bursts, the Itty Bitty Telescope (IBT), dark matter, black holes, the Jansky antenna, methanol masers, mapping at 408 MHz and more.

New! SARA On-Demand Store: <https://saragifts.org>

These are the current items – more to come in the future!

(Note: No returns or refunds possible because of the on-demand production approach)





SARA Brochure

Membership Information

Annual SARA dues Individual \$20, Classroom \$20, Student \$5 (US funds) anywhere in the world. Membership includes a subscription to Radio Astronomy, the bimonthly Journal of The Society of Amateur Radio Astronomers, delivered electronically (via a secure web link, emailed to you as each new issue is posted). We regret that printing and postage costs prevent SARA from providing hardcopy subscriptions to our Journal.

We would appreciate the following information included with your check or money order, made payable to SARA:

Name: _____
 Email Address: _____
(required for electronic Journal delivery)
 Ham call sign: _____
(if applicable)
 Address: _____
 City: _____
 State: _____
 Zip: _____
 Country: _____
 Phone: _____

Please include a note of your interests. Send your application for membership, along with your remittance, to our Treasurer.

For further information, see our website at: <http://radio-astronomy.org/membership>



Society of Amateur Radio Astronomers, Inc.
 Founded 1981

Membership supported, nonprofit 501(c)(3)
 Educational and Radio Astronomy Organization
**Knowledge through Common Research,
 Education and Mentoring**

How to get started?

SARA has a made a kit of software and parts to detect the Hydrogen line signal from space. This is an excellent method to get started in radio astronomy. It teaches the principles of antenna design, signal detection, and signal processing. Read more about this and other projects on our web site.

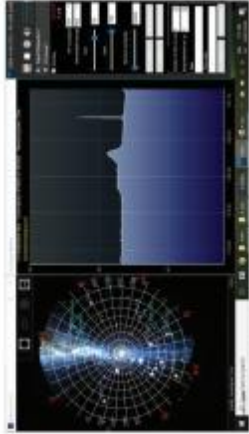

SARA members have been privileged to use this forty foot diameter drift-scan hydrogen line radio telescope every year at their annual meeting in Green Bank.

Why Radio Astronomy?

Because about sixty five percent of our current knowledge of the universe has stemmed from radio astronomy alone. The discovery of quasars, pulsars, black holes, the 3K background from the "Big Bang" and the discovery of biochemical hydrogen/carbon molecules are all the result of professional radio astronomy.



<http://radio-astronomy.org>

The Society of Amateur Radio Astronomers

SARA was founded in 1981, with the purpose of educating those interested in pursuing amateur radio astronomy.

The society is open to all, wishing to participate with others, worldwide.

SARA members have many interests, some are as follows:

SARA Areas of Study and Research:

- ✔ Solar Radio Astronomy
- ✔ Galactic Radio Astronomy
- ✔ Meteor Detection
- ✔ Jupiter
- ✔ SETI
- ✔ Gamma Ray/High Energy Pulse
- ✔ Detection
- ✔ Antennas
- ✔ Design of Hardware / Software

The members of the society offer a friendly mentor atmosphere. All questions and inquiries are answered in a constructive manner. No question is silly!

SARA offers its members an electronic bi-monthly journal entitled Radio Astronomy. Within the journal, members report on their research and observations. In addition, members receive updates on the professional radio astronomy community and, society news.

Once a year SARA meets for a three-day conference at the Green Bank Observatory in Green Bank West Va.

There is also a spring conference held at various cities in the Western USA. Previous meetings have been at the VLA in Socorro, NM and at Stanford University.



How do I get started?

Just as a long journey begins with the first step, the project you elect must start with a clear idea of your objectives. Do you wish to study the sun? Jupiter? Make meteor counts? Do you wish to engage in imaging radio astronomy? What you decide will not only determine the type of equipment you will need, but also the local radio spectrum.

How do amateurs do radio astronomy?

Radio astronomy by amateurs is conducted using antennas of various shapes and sizes, from smaller parabolic dishes to simple wire antennas. These antennas are connected to receivers and most of these receivers are software defined radios these days. Data from the receivers are collected by computers, and the received signals will be displayed as charts, graphs or maybe even sky maps. As diverse as the observed objects, so is the instruments and tools used. SARA members will always be supportive to find good solutions for what one wishes to observe.

Is amateur radio astronomy instrumentation expensive?

Technical information freely circulated in our monthly journal helps amateurs to obtain good low noise equipment from off the shelf assemblies, or to build their own units. The actual cash investment in radio astronomy equipment need not exceed that of any other hobby.

What are amateurs actually looking for in the received data?

The aim of the radio amateur is to find something new and unusual. Just as an amateur optical observer hopes to notice a supernova or a new comet, so does an amateur radio observer hope to notice a new radio source, or one whose radiation has changed appreciably.



The Reber Telescope at NRAO. Constructed by Grote Reber in 1937 in his back yard in Wheaton, Illinois



SARA Members discussing the IBT (Itty Bitty Telescope)

