

# RADIO ASTRONOMY

Journal of the Society of Amateur Radio Astronomers  
January-February 2023



**Jim Carroll (N4CAE)**  
showing Grote Reber his SARA 408 MHz receiver project  
at SARA Conf '96.



**Dr. Richard A. Russel**  
*SARA President and Editor*

**Whitham D. Reeve**  
*Contributing Editor*

Radio Astronomy is published bimonthly as the official journal of the Society of Amateur Radio Astronomers. Duplication of uncopyrighted material for educational purposes is permitted but credit shall be given to SARA and to the specific author. Copyrighted materials may not be copied without written permission from the copyright owner.

Radio Astronomy is available for download only by SARA members from the SARA web site and may not be posted anywhere else.

It is the mission of the Society of Amateur Radio Astronomers (SARA) to: Facilitate the flow of information pertinent to the field of Radio Astronomy among our members; Promote members to mentor newcomers to our hobby and share the excitement of radio astronomy with other interested persons and organizations; Promote individual and multi station observing programs; Encourage programs that enhance the technical abilities of our members to monitor cosmic radio signals, as well as to share and analyze such signals; Encourage educational programs within SARA and educational outreach initiatives. Founded in 1981, the Society of Amateur Radio Astronomers, Inc. is a membership supported, non-profit [501(c) (3)], educational and scientific corporation.

Copyright © 2023 by the Society of Amateur Radio Astronomers, Inc. All rights reserved.

Cover Photo:

Charles Osborne

## Contents

<b>President’s Page</b> .....	2
Editor’s Notes.....	3
<b>SARA NOTES</b> .....	4
<b>SARA 2023 Western Conference</b> .....	6
<b>SARA 2023 Eastern/Annual Conference</b> .....	16
<b>News: (January-February 2023)</b> .....	19
<b>Technical Knowledge &amp; Education (January-February 2023)</b> .....	22
<b>Announcements (January-February 2023)</b> .....	25
SuperSID.....	31
Announcing Radio JOVE 2.0.....	34
John Cook's VLF Report.....	40
BAA RA Section Winter programme 2023.....	61
<b>VINTAGE SARA</b> .....	62
<b>Featured Articles</b> .....	64
An HI Telescope Using an Odroid XU4 Single Board Computer-Tom Hagen.....	64
Comparison of Inexpensive 10 MHz GNSS Disciplined Oscillators-Whitham D. Reeve.....	73
<b>Observation Reports</b> .....	88
Meteor Trail Reflections Observed at Anchorage, Alaska – Whitham D. Reeve.....	88
A Look at 1420 MHz Observations from Opposite sides of the Sun-Charles Osborne..	90
Sudden Frequency Deviations Observed at Anchorage, Alaska- Whitham D. Reeve....	98
<b>Journal Archives and Other Promotions</b> .....	100
What is Radio Astronomy?.....	101
<b>Administrative</b> .....	102
Officers, directors, and additional SARA contacts.....	102
<b>Resources</b> .....	103
Great Projects to Get Started in Radio Astronomy.....	103
Radio Astronomy Online Resources.....	105
<b>For Sale, Trade and Wanted</b> .....	106
<b>SARA Advertisements</b> .....	108
SARA Brochure.....	109

## President's Page



### **Finally, we are ready to start live meetings again!**

I want to thank David Westman for his outstanding organization of the Western Conference.

The Eastern/Annual conference is also shaping up due to the excellent work of our esteemed VP, Jay Wilson. Get your abstracts started to participate.

SARA has added the southern hemisphere to our membership roles with the addition of the Drake's Lounge – Australia ZOOM meetings we are having monthly.

We are still looking volunteers for the Education and Membership chairs. Both of these positions will help retain membership and reduce the load on our treasurer.

We are holding three ZOOM meetings a month now. Feel free to log in and talk to your fellow amateur radio astronomers.

Thanks!

Rich  
SARA President

## Editor's Notes

We are always looking for basic radio astronomy articles, radio astronomy tutorials, theoretical articles, application and construction articles, news pertinent to radio astronomy, profiles and interviews with amateur and professional radio astronomers, book reviews, puzzles (including word challenges, riddles, and crossword puzzles), anecdotes, expository on "bad astronomy," articles on radio astronomy observations, suggestions for reprint of articles from past journals, book reviews and other publications, and announcements of radio astronomy star parties, meetings, and outreach activities.

## Subscribe to the SARA YouTube Channel

SARA has a YouTube channel at: <https://www.youtube.com/channel/UC-SzptAQZ-20c9CkRb9ZPpw/videos>

We are also looking to add content to the site. Anyone who wants to help produce a series of 5 - minute videos relating to radio astronomy technology or observations please contact me. ([drrichrussel@netscape.net](mailto:drrichrussel@netscape.net))

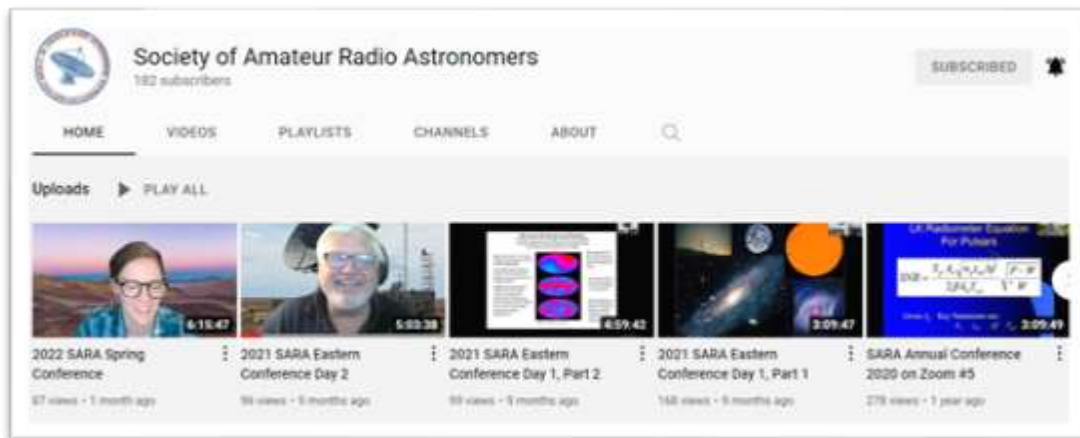

## Observation Reports

We are now accepting 1-2 page observation reports. These reports should include the astronomical object's RA/DEC plus UTC of the observation. Also include the telescope configuration, process used to observe the object and results. Picture of the setup and plots of the observation are a plus to the report.

If you would like to write an article for Radio Astronomy, please follow **the newly updated Author's Guide** on the SARA web site:

[http://www.radio-astronomy.org/publicat/RA-JSARA\\_Author's\\_Guide.pdf](http://www.radio-astronomy.org/publicat/RA-JSARA_Author's_Guide.pdf).

Let us know if you have questions; we are glad to assist authors with their articles and papers and will not hesitate to work with you. You may contact your editors any time via email here: [edit@radio-astronomy.org](mailto:edit@radio-astronomy.org).

The editor(s) will acknowledge that they have received your submission within two days. If they do not reply, assume they did not receive it and please try again.

Please consider submitting your radio astronomy observations for publication: any object, any wavelength. Strip charts, spectrograms, magnetograms, meteor scatter records, space radar records, photographs; examples of radio frequency interference (RFI) are also welcome.

Guidelines for submitting observations may be found here: [http://www.radio-astronomy.org/publicat/RA-JSARA\\_Observation\\_Submission\\_Guide.pdf](http://www.radio-astronomy.org/publicat/RA-JSARA_Observation_Submission_Guide.pdf)

## SARA NOTES

### SARA Student & Teacher Grant Program

All, SARA has a grant program that is, sad to say very underutilized. We will provide kits or money to students and teachers including college students to help them with a radio telescope project. SARA can supply any of the following kits:

- [1] SuperSID
- [2] Scope in a Box
- [3] IBT (Itty Bitty Telescope)
- [4] Radio Jove kit
- [5] Inspire
- [6] Sky Scan

We can also provide up to five hundred dollars (\$500.00 USD) for an approved radio telescope project.

We have on occasion provided more money based on the merits of the project and the SARA Grant Committee approval.

More information on the grant program can be found at the URL below.

[SARA Student and Teacher Project Grants | Society of Amateur Radio Astronomers \(radio-astronomy.org\)](https://www.radio-astronomy.org/)

All that is required is the SARA grant request form be filled out and sent in. If it needs more work for approval, we will work with the student to help ensure their success.

Please pass the word that SARA will fund any legitimate radio telescope project anywhere in the world.

If you have a question, contact me at [crowleytj at hotmail](mailto:crowleytj@hotmail.com) dot com.

Tom Crowley  
SARA Grant Program Administrator

### **NEW** Drake's Lounge Australia

This new zoom forum is geared to the Melbourne, Australia time zone (UTC+10) in order to improve coordination with our Australia, New Zealand, and Japanese members. The meetings are scheduled for the 4th Friday of every month, 9 AM Melbourne time (2000 UTC December 23). A zoom announcement will be sent out to all SARA members before the meeting.

## **Radio Telescope Observation Party (RTOP)**

RTOP is designed to demonstrate how to take observations using various radio telescopes. It will also cover how to record and analyze data.

RTOP is every month on the 1<sup>st</sup> Sunday at 2 pm Eastern time (1800 UTC). ZOOM email notifications will be sent to all members.

## **Drake's Lounge**

Join the SARA community as we discuss the latest astronomy and radio astronomy news. The lounge also provides a forum to share and get advice on your radio astronomy projects from very experienced amateur radio astronomers.

Drake's Lounge is every month on the 3<sup>rd</sup> Sunday at 2 pm Eastern time (1800 UTC). ZOOM email notifications will be sent to all members.

**2023 SARA Western Conference**

Bishop, California, USA on 17 and 18 March, 2023

The 2023 SARA Western Conference will be held at Bishop, California at the Owens Valley Radio Observatory on Friday and Saturday, 17 and 18 March 2023. OVRO is operated by California Institute of Technology and is located about 20 miles southeast of Bishop.

From the OVRO website (<http://www.ovro.caltech.edu/>): *“The Owens Valley Radio Observatory (OVRO) is one of the largest university-operated radio observatories in the world. Known by locals as ‘The Big Ears’, the observatory is located near Bishop, California, approximately 250 miles north of Los Angeles on the east side of the Sierra Nevada. For reference, its coordinates are 37:14:02N latitude, 118:16:56W longitude at 1222 meters above sea level. ...”*

Image below from <http://www.ovro.caltech.edu/>



**Call for papers:** Papers are welcome on subjects directly related to radio astronomy including hardware, software, education and tutorials, research strategies, observations and data collection and philosophy. If you wish to present a paper please email a letter of intent, including a proposed title and abstract to the conference coordinator at [westernconf@radio-astronomy.org](mailto:westernconf@radio-astronomy.org) no later than 20 December 2022.

Be sure to include your full name, affiliation, postal address, and email address, and indicate your willingness to attend the conference either in person or virtually to present your paper. Submitters will receive an email response, typically within one week. Final advance presentations should be submitted to the Western Conference co-ordinator for inclusion in the proceedings no later than March 1, 2023. Due to the work required to prepare the proceedings, this should be considered a hard deadline.

**Presentations and proceedings:** In addition to presentations by SARA members, we have asked Dr. Vikram Ravi of CalTech to be the keynote speaker for the conference. His presentation will be on “Renewing our view of the radio sky”.

Papers and presentations on radio astronomy hardware, software, education, research strategies, philosophy, and observing efforts and methods are welcome. Formal proceedings will be published for this conference. If presenters want to submit a paper or a copy of their presentation, we will make them available to attendees on a flash drive.

**Basic schedule:** The conference will be entirely held at Owens Valley Radio Observatory with presentations by SARA members and supporters and OVRO staff followed by a tour of the OVRO facilities. Virtual attendance at the conference will be possible at a reduced rate for those who cannot attend in person.

**Contact:** Please contact conference coordinator David Westman if you have any questions or if you would like to help with the conference: [westernconf@radio-astronomy.org](mailto:westernconf@radio-astronomy.org).

**Getting there:** Bishop and OVRO are located in a valley between the eastern Sierra Nevada and White Mountains. Because of the remote location we recommend conference participants make their travel plans and hotel and rental car reservations early. Possibilities are to fly into San Francisco (SFO) and connect to the regional airport at Eastern Sierra Airport (BIH), 2 miles from of Bishop. The airline traveling into Eastern Sierra is United Airlines, which has marketing agreements with a number of airlines including American Airlines.

**Registration:** Registration for in person attendance at the 2023 Western Conference is just US\$55.00. The reduced rate to attend the conference on line is \$15. You must be a SARA



member to register for the conference. The in person conference rate will include lunch at the conference site on Friday and Saturday. Payment can be made through PayPal, [www.paypal.com](http://www.paypal.com) by sending payment to [treas@radio-astronomy.org](mailto:treas@radio-astronomy.org). If you need to send a check for registration, please send it to SARA Treasurer (c/o Brian O'Rourke), 337 Meadow Ridge Road Troy, VA 22974-3256. Please include in comments that the payment is for the **2023 Western Regional Conference**.

**Hotel reservations:** There are many hotels and motels in Bishop with reasonable rates. The Bishop Inn offers rooms from \$63 a night, and the El Rancho Motel rates start at \$98 per night. The Best Western Bishop motel rates start at \$135 per night, and others can be found in the same range.

**Saturday night dinner:** We will make a group dinner reservation at a local restaurant for Saturday night.

**Additional Information:** Additional details will be published online at [www.radio-astronomy.org](http://www.radio-astronomy.org) and in the SARA journal, *Radio Astronomy*, as we get closer to the conference date.



**Dr. Vikram Ravi**  
**Keynote Speaker**  
at the  
**SARA 2023 Western Conference**  
Owens Valley Radio Observatory  
Bishop, CA

Dr. Ravi is an Assistant Professor of Astronomy in the Caltech astronomy department. His professional focus is on exploring and understanding the ephemeral, unseen Universe. He studies phenomena that vary on time-scales of nanoseconds to years, such as fast radio bursts, the tidal disruptions of stars by supermassive black holes, neutron-star outbursts, the radiation statistics of astrophysical masers and lasers, and gravitational waves from binary supermassive black holes. He also seeks to understand the distribution and physical nature of diffuse and hot matter around and in between galaxies. His research interests are detailed below.

He is an Australian of Indian origin. Educated at the Valley School, Bangalore, and Narrabri High School, NSW Australia, (and by his astronomer parents!), He studied physics as part of the Bachelor of Philosophy (PhB) at the Australian National University. The PhB also offered remarkable research opportunities: as an undergrad, he worked in a Bose-Einstein condensate lab, and he also investigated new ways of modelling the Earth's climate. He undertook Honours research with Prof. Dayal

Wickramasinghe, and Dr. George Hobbs, on coherent radio emission from stars (more below). While at University, he resided at Burgmann College.

He spent the Fall of 2008 on exchange at the University of California, Berkeley. An undergraduate research apprentice program with Prof. Charles Townes and the [Infrared Spatial Interferometer](#) group led to his employment at UC Berkeley during 2010-11 as a Junior Specialist. He studied yearly changes in the atmosphere of Betelgeuse, and worked with the [CASPER](#) group to develop an instrument to image shells of water around similarly evolved stars.

He completed his PhD (accepted Jan 2015) at the University of Melbourne, with [Prof. Stuart Wyithe](#) and Dr. George Hobbs (at CSIRO Astronomy and Space Science). He developed predictions for gravitational-wave signals from orbiting pairs of supermassive black holes in merging galaxies, and tested these using decade-long timing data on millisecond pulsars from the [Parkes telescope](#). His work provided the theoretical basis for two papers published in Science, led by [Dr. Ryan Shannon](#), and resulted in two major thesis prizes, and his being invited to talk ([video below](#)) at a Kavli Frontiers of Science meeting in Makassar, Indonesia.

During his PhD, he also engaged in a selection of madcap ventures: investigations into an ultra-broadband pulsar system for the Australia Telescope Compact Array, searches for off-pulse emission and wind nebulae associated with a large pulsar sample, constraining the equation of state of matter at nuclear densities with gamma-ray burst and fast radio burst observations, and successful searches for fast radio bursts.

He then spent a part of 2014-15 working with Prof. Matthew Bailes and his group at Swinburne University on the nascent upgrade of the Molonglo Observatory to form a fast transient, pulsar and wide-field imaging behemoth ([UTMOST](#)).

He has since spent 2015-18 as a Millikan Fellow in Astronomy at Caltech, and 2018-19 as a Clay Fellow at the [Center for Astrophysics | Harvard and Smithsonian](#).

**SARA Western Conference**  
**March 17-18, 2023**  
**Conference Schedule (V = virtual speaker)**

<b>Time, PDT [UTC]</b>	<b>Activity/Title</b>	<b>Presenter</b>	<b>Location</b>
<b>Friday, March 17th</b>			
8:00 – 9:00 [15:00]	Registration, Breakfast		
9:00 – 9:15 [16:00]	Introductions, etc.	David Westman, Rich Russel	
9:15 – 10:00 [16:15]	Keynote Speech: Renewing our view of the radio sky	Vikram Ravi, CalTech	
10:00 – 10:45 [17:00]	Observations of Ultra- Low Frequency Waves at Anchorage, Alaska	Whitham Reeve (V)	
10:45 – 11:15 [17:45]	Morning Break		
11:15 – 12:00 [18:15]	The 2021/2022 Observation Campaign of FRB20201124A	Wolfgang Herrmann, Astropeiler Stockert e.V. (V)	
12:00 – 1:15 [19:00]	Lunch		
1:15 – 2:15 [20:15]	SARA Eastern Conference Preview	Jay Wilson	
2:15 – 4:45 [21:15]	Tour of OVRO		OVRO site
6:00 – [1:00 3/18]	Dinner at restaurant		
<b>Saturday, March 18th</b>			
8:30 – 9:00 [15:15]	Breakfast		
9:00 – 9:45 [16:00]	ATSU 1) STEMSAT-1 Launching December 2023!	Dr. Wayne McCain, ATSU	
9:45 – 10:30 [16:45]	ATSU 2) Building A Simple, Low-Cost Ground Tracking Station For Receiving the STEMSAT	David O. Ausley, ATSU, & Amelia Claire McCain, Athens Middle School	
10:30 – 11:00 [17:30]	Morning Break		
11:00 – 11:45 [18:00]	ATSU 3) VLF Radio Signals From Space - What Can STEMSAT Expect?	Dr. Mel Blake & Harmonie R. Wildharber, UNA	
11:45 – 12:45 [18:45]	Lunch		
12:45 – 1:30 [19:45]	ATSU 4) The Future Is Now - An Overview of the BS in Aerospace Systems at Athens State University	Dr. Mary Jo Marggraff & Dr. J. Wayne McCain ATSU	
1:30 – 2:15 [20:30]	Exploring Pulsar Timing Residuals	Dan Layne, DSES	
2:15 – 2:45 [21:15]	Afternoon Break, Group Picture		
2:45 – 3:30 [21:45]	Principles of and a Proposed Phased Array Radio Telescope	Curt Kinghorn	
3:30-4:15 [22:30]	SARA Board Meeting	Rich Russel	

Last update: 13-Feb-2023 DBW

## **Abstracts for 2023 Western Conference**

OVRO, Bishop, CA, March 17-18, 2023

### **Keynote speech: Dr. Vikram Ravi, Caltech**

Title: Renewing our view of the radio sky

Radio astronomy is changing. Where large, multi-user facilities operated by national observatories were once pre-eminent, the field is entering an era of experiments with diversified, dedicated instrumentation. This is powered by the drastic reduction in cost and democratization of access to cutting-edge receiver and digital signal processing hardware. The Owens Valley Radio Observatory (OVRO) is a microcosm, and pioneer, of this transformation, with several large projects underway that address some of the most exciting questions in astronomy: the habitability of exoplanets, matter at the very edges of black holes, the sources of the enigmatic fast radio bursts (FRBs), and the origins of the foam of galaxies we call the cosmic web. I will focus on the Deep Synoptic Array (DSA) program. The DSA-10 and DSA-110 arrays were targeted at pinpointing FRBs to specific galaxies, thus illuminating their origins, and enabling their use as probes of the large-scale structure of the Universe. In the near future, the DSA-2000 array will be the most powerful radio telescope yet built, exceeding the survey speed of the Square Kilometre Array by a factor of six while matching its sensitivity. Consisting of 2000 5-m dishes operating between 0.7-2 GHz and distributed over a 19x15km site in Nevada, the DSA-2000 will inform our cosmic history from the earliest galaxies to our Milky Way, reveal the rarest types of neutron stars, and unravel the astrophysics of gravitational-wave sources. We are little over a year from construction starting on the DSA-2000, and this talk will be presented from the epicenter of this project!

**Title:** Observations of Ultra-Low Frequency Waves at Anchorage, Alaska

**Author:** Whitham D. Reeve

The solar wind is the agent for many interesting geomagnetic phenomena recorded by ground magnetometers. Among these are Ultralow Frequency Waves (ULF Waves), the modern name given to periodic variations in Earth's magnetic field observed on the ground. The phenomenon has been known throughout the years by several other names including micropulsations and magnetic pulsations. ULF waves have frequencies of a few MHz to a few Hz, corresponding to periods from several minutes to fractions of a second.

ULF Waves have wavelengths comparable to the scale size of the magnetosphere and play a fundamental role in transporting energy throughout the geospace system. Scientific investigations of ULF Waves reveal information about the magnetosphere's particle density and structure, particularly in the parts of the magnetosphere that are hard to directly measure. An ultimate goal of these studies is a better understanding of space weather and its effects on Earth and technology. In spite of considerable work over many years, the causes of ULF Waves are not yet fully understood. Indeed, the scientific literature contains conflicts in many details.

This paper contains two parts: Part I provides 1) a tutorial on ULF Waves, 2) ULF Wave classifications, 3) a brief description of the Anchorage Radio Observatory, and 4) a description of the SAM-III magnetometer used to collect

the data; Part II provides descriptions of ULF Wave observations at Anchorage, Alaska from 2010 to 2022 and a discussion of those observations.

**Title:** The 2021/2022 Observation Campaign of FRB20201124A

**Author:** Wolfgang Herrmann, Astropeiler Stockert e.V.

Fast Radio Bursts (FRBs) are bright pulses which are believed to come from cosmological distances due to their large dispersion. Some of these pulses repeat, and such a repeater is known as FRB20201124A. This source has been observed by the 25-m dish of the Astropeiler observatory during the period from April, 2021 to March, 2022, accumulating ~ 1400 hours of on-source time. This observation activity was complemented by observations with the Westerbork (Netherlands), Onsala (Sweden) and Torun (Poland) telescopes. A total of 46 bursts were detected.

The talk will give an overview of the observation campaign and the science results derived from the observations.

## **Conference Presentations from Athens State University on the STEMSTAT project**

**Title:** 1) STEMSAT-1 Launching December 2023!

**Author:** Dr. J. Wayne McCain, Athens State University

STEMSAT-1 (formerly known as SARA-SAT1) is manifested for launch late fourth quarter 2023 on a Vaya Space hybrid rocket from Cape Canaveral Space Force Station along with another commercial satellite. First announced at the 2017 Western Conference, the primary objective of this 3U cubesat is to involve students from kindergarten through college level in various aspects of designing, building, launch, and mission control of the satellite as a STEM learning activity. The secondary scientific mission is to monitor VLF (50-200 KHz range) radio signals that won't otherwise penetrate the Earth's atmosphere and translate that data to a UHF, 430 MHz that is transmitted to ground stations world-wide. This paper will update the progress on STEMSAT, including the project's collaboration with SARA.

**Title:** 2) Building A Simple, Low-Cost Ground Tracking Station For Receiving the STEMSAT

**Authors:** David O. Ausley, Athens State University Alumnus, Amelia Claire McCain, Student, Athens Middle School

Once the STEMSAT small satellite is launched into orbit, ground stations worldwide (ranging from Hawaii, South Africa, to Wales) will be able to capture the translated VLF radio signal data on the 70 cm Ham Radio band. This paper summarizes simple and homebuilt antennas and inexpensive handheld radios that can serve to receive the satellite data.

**Title:** 3) VLF Radio Signals From Space - What Can STEMSAT Expect?

**Authors:** Dr. Mel Blake, Resident Astronomer, University of North Alabama (UNA), Harmonie R. Wildharber, Student, UNA

What are some of the radio signals that the STEMSAT satellite may encounter in its low to medium altitude Earth orbit and what is the significance of their translation to UHF frequency and transmission/reception on Earth? This paper is based on research into these topics by UNA student Harmonie Wildharber (an Alabama Academy of Science research winner) and her faculty advisor and Resident Astronomer Dr. Mel Blake.

**Title:** 4) The Future Is Now - An Overview of the BS in Aerospace Systems at Athens State University

**Authors:** Dr. Mary Jo Marggraff, Adjunct Professor Athens State University, Dr. J. Wayne McCain, Professor

There is a new 'space race' underway driven largely by the involvement of commercial players such as Elon Musk's SPACE-X and others in the marketplace. To the Moon - then Mars! But, shortages in professional labor sources abound in the aviation and space-based industries. This paper introduces a new degree program at Athens State University to facilitate training in the very skill sets that are required to ease these labor shortfalls.

The program includes Aviation Management and Space Systems concentrations. Athens State has teamed with Wallace State Community College for actual pilot training.

\*\*\*\*\*

**Title:** Exploring Pulsar Timing Residuals

**Author:** Dan Layne, Deep Space Exploration Society

Pulsars are highly magnetized, rapidly rotating neutron stars. **Pulsar timing** is the regular monitoring of the rotation of a neutron star by tracking the arrival times of the radio pulses at the telescope. Averaging over many pulses yields an average pulse profile. Although the shapes of individual pulses can vary considerably, the shape of the average profile at a given observing frequency is quite stable. For timing, the average pulse profile is correlated with a high signal-to-noise template to determine the pulse **time of arrival (TOA)**. **Timing residuals** are the differences between the observed TOAs and the predicted TOAs based on the current timing model parameters. Strong **millisecond pulsars (MSPs)** with narrow pulse profiles provide the most accurate arrival times. An array of such MSPs spread over the sky is called a **pulsar timing array (PTA)**. The goal of a PTA is to detect correlated structures in the timing residuals of dozens of MSPs, potentially including distortions of interstellar space from nanohertz (i.e., periods of years) gravitational waves passing through our galaxy. The purpose of this paper is to explore timing residuals and noise modeling of individual MSPs from the NANOGrav PTA project. Specifically, narrowband parametric models and TOA timing data from the NANOGrav 12.5 year data set are used to analyze a few brighter MSPs, including PSRs J1713+0747, B1937+21 and J2145-0750. Pulsar detection is illustrated with PRESTO plots from the Green Bank Observatory 20-meter telescope, while the actual NANOGrav timing data was collected with Arecibo and the Green Bank 100-meter Telescope from 2004 to 2017. The narrowband models are based on a generalized least squares fit of parameters that includes uncorrelated white noise as well as red noise. Software tools include TEMPO2 and PINT (high precision pulsar timing), as well as ENTERPRISE, which provides Bayesian inference methods for reasoning with uncertain timing and noise models.

**Title:** Principles of and a Proposed Phased Array Radio Telescope

**Author:** Curt Kinghorn

An explanation will be made of the principles and components of phased arrays as applied to a radio astronomy telescope including a comparison of a phased array telescope to an interferometer and a single antenna system. In addition, the presentation will also include a brief description of antennas, their applications to radio astronomy systems generally and in particular to phased array telescopes. Using these phased array principals, a proposed amateur aperture synthesis phased array telescope system will be presented. The telescope, though amateur, would be a scientifically powerful and useful scope. The scientific purpose of the telescope will be to measure time-varying radio phenomena on time scales of microseconds to an hour and also on time scales of several months. The proposed telescope will be able to record data at four frequencies, 50 MHz, 100 MHz, 200 MHz and 400 MHz to provide a spectral sky survey as well. The System should be able to identify and map FRBs, pulsars, transients and the evolution of phenomena such as expanding supernova remnants. The proposed scope should also complement the astrometric and photometric work being done to great effect in visual astronomy. Similar to the SuperSID distributed by SARA, the proposed system would be deployed continent-wide by amateurs in any number of locations. The telescope would be an improvement on and add to the scientific knowledge shown in a 2003 paper titled *A Survey for Transient Astronomical Radio Emission at 611 MHz*, Katz, C.A., Hewitt, J. N. et al, <https://arxiv.org/abs/astro-ph/0304260>



**2023 SARA Annual Conference  
Green Bank Observatory  
Green Bank, West Virginia,  
2023 20-23 August 2023**

The 2023 SARA Annual Conference will be held at the Green Bank Observatory, West Virginia, Sunday through Wednesday, 20-23 August 2023.

SARA has traditionally held our Eastern Conferences at GBO, and we are very pleased to return following a two-year hiatus due to COVID.

With radio astronomy as its foundation, the Green Bank Observatory (GBO) is a world leader in advancing research, innovation, and education.

The first trailblazers of American radio astronomy called Green Bank Observatory home over 60 years ago. Today, their legacy is alive and well. Nestled in the mountain ranges and farmland of West Virginia, within the National Quiet Zone, radio astronomers are listening to the remote whispers of the universe, in order to discover answers to our most astounding astronomical questions.



**Call for Papers**

Papers are invited on all subjects related to amateur, scholastic, or professional radio astronomy including hardware, software, education, tutorial, outreach, research strategies, observation, data collection, philosophy, theoretical or practical challenges, and related subjects.

If you wish to present a paper or provide an exhibit, please email a proposal including a title and abstract to the conference coordinator at [vicepresident@radio-astronomy.org](mailto:vicepresident@radio-astronomy.org) no later than 30 April 2023.

Please include your full name, affiliation, CV if appropriate, postal address, and email address, and indicate your preference to present to the conference in person or virtually. You will receive an email response within about a week.

Complete papers are due on July 15, 2023. Presentation Slides / PowerPoints are due on August 10, 2023.

**Basic Schedule:** Conference meetings will be held in the main auditorium of the Jansky Laboratory at Green Bank Observatory with presentations by SARA members, GBO staff and distinguished speakers. Security and COVID restrictions permitting, tours of the facility, radio telescopes and laboratories will be conducted. Certain locations are open only to U.S. citizens who submit for a security review two weeks prior; however, other areas will be open to all attendees. Virtual participation in the conference will be available for those who cannot attend in person.

Key advantage of in-person attendance is training and hands-on use of the historical 40-foot radio telescope as well as user tutorial on the 20 meter radio telescope.

On Sunday and Monday evenings, round table discussions and refreshments are scheduled in the Drake Lounge, and there will be space outside for attendees to set up and display their own portable radio astronomy systems and optical telescopes.

Meals in the GBO cafeteria are included in the registration fee.

**Lodging is not included in the conference registration fee.** A few GBO dormitory rooms may be available and can be requested on a first-come-first-served basis when you register for the conference. All available rooms are usually needed for conference presenters and SARA officers working at the conference, but if additional rooms become available, they will be offered to other attendees on a first-come basis about 10 days before the conference. Attendees staying in GBO rooms pay the observatory housing office by check or charge card on Monday afternoon of the conference. Expected rates are \$75 single occupancy or \$95 double.

No-frills rooms and RV/camping sites are available at the nearby Boyer Station Motel and Campground. The Elk Springs Resort is about 12 miles away. Many chain accommodations are located about 30 miles away in Elkins, but that drive takes at least an hour due to mountainous roads.

**Registration:** Registration for in-person attendance by SARA members at the Conference is \$275.00 (USD) if received by July 20, 2023, which includes meals but not lodging. The fee for family members or other guests who do not participate in conference sessions is \$75.00, which includes meals plus evening activities.

Registration by July 20th for non-members is \$295.00, which includes a year's membership in SARA.

SARA members wishing to renew their membership at the same time as they register may also pay \$295 and should include a renewal comment with their payment.

Late registration after July 20, 2023, is \$325.00, with very little chance of on-campus housing. Walk-in registration at the conference is \$350.00 with no on-campus housing option.

Payment can be made through PayPal, [www.paypal.com](http://www.paypal.com) by sending payment to [treas@radio-astronomy.org](mailto:treas@radio-astronomy.org) Please include in comments that the payment is for the **2023 Annual Conference** and indicate if you would like on campus housing for single or double occupancy if it becomes available.

**COVID Restrictions.** GBO reserves the right to impose requirements for vaccinations and masks. SARA will notify all registrants should GBO issue a policy statement. Should GBO policies adversely impact a conference registrant, they may change their registration from in-person to virtual / online and receive a refund for the difference. Should GBO close the campus for any reason, all registrations will be changed to virtual / online.

**Cancellations.** Full refund minus PayPal transaction fees will be issued for cancellations received by July 31, 2023. After July 31, cancellations will be handled on a case-by-case basis. SARA will strive to issue partial refunds based on the non-refundable obligations we have made.

**No Cellular Phone Service.** GBO is in the National Radio Quiet Zone and there is no wireless phone service in the area. Use of wi-fi devices and satellite phones such as Iridium, Globalstar, StarLink or similar devices near the facility is not allowed, and severe restrictions are placed on digital cameras, although film cameras without electronic flash are allowed in most areas of the site. Some dorm rooms have wired internet connections for portable computers and there is a computer lab available during the day. Some dorm rooms have phones for incoming calls. Outgoing calls require a calling card. In case of family or business emergencies, GBO Operations can be reached at 304-456-2150.

**Pre-Conference Activities.** Suggested pre-conference activities include free self-guided tours of the Green Bank Observatory Science Center and reasonably priced guided tours of the radio telescope area. Full details with a link for ticket purchase: <https://greenbankobservatory.org/visit/>

An overall guide to other activities and attractions in the area: <https://pocahontascountywv.com/things-to-do/>

**Contact: Please contact the conference coordinator, B.J. Wilson, if you have any questions or if you would like to help with the conference: [vicepresident@radio-astronomy.org](mailto:vicepresident@radio-astronomy.org)**

**Additional Information:** Additional details and updates will be published online at [www.radio-astronomy.org](http://www.radio-astronomy.org) and in the SARA journal, *Radio Astronomy*, as we get closer to the conference date.

## News: (January-February 2023)

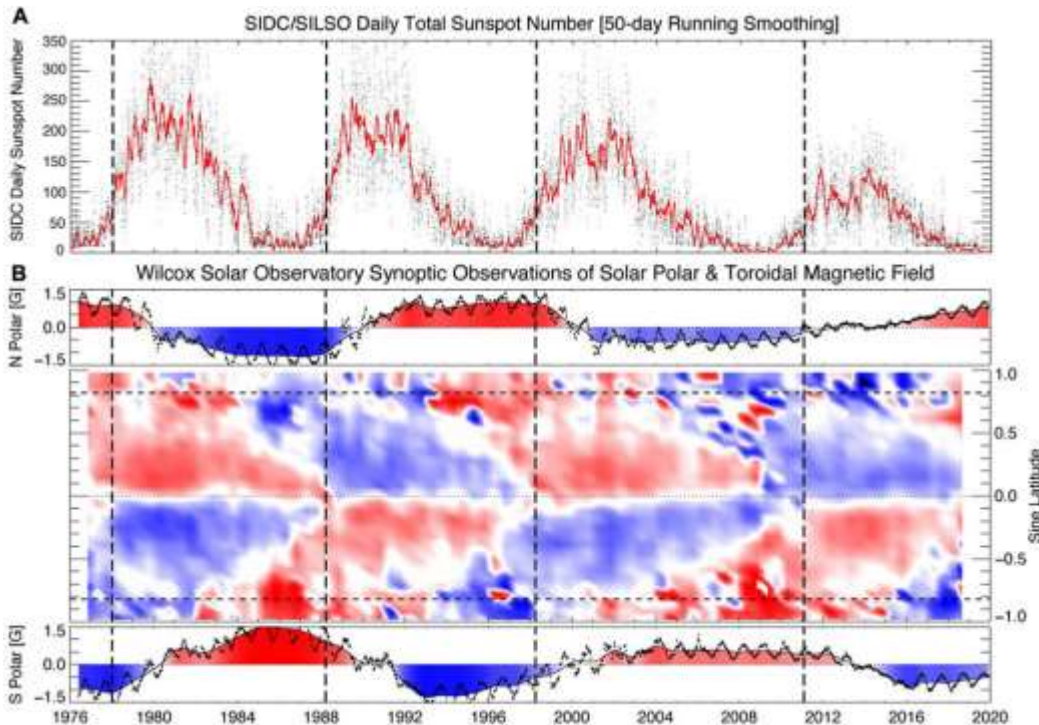

Frontiers ~ Uniting the Sun's Hale magnetic cycle and "extended solar cycle" paradigms:  
<https://www.frontiersin.org/articles/10.3389/fspas.2022.923049/full>

EurekaAlert ~ FAST reveals unprecedented details of the Milky Way:  
<https://www.eurekaalert.org/news-releases/974117>

Hey, Mac, what's up with that probing?: Universe Today ~ Astronomers Scanned 12 Planets for Alien Signals While They Were in Front of Their Stars:  
<https://www.universetoday.com/159219/astronomers-scanned-12-planets-for-alien-signals-while-they-were-in-front-of-their-stars/>

ArXiv ~ Space Weather: From Solar Origins to Risks and Hazards Evolving in Time:  
<https://arxiv.org/abs/2212.11504>

University of Oulu ~ Cosmic Ray Station: <https://cosmicrays oulu.fi/>

Spaceweather.com ~ The Extended Solar cycle:  
<https://spaceweather.com/archive.php?view=1&day=13&month=12&year=2022> (Note: SARA members will recognize the principal names in this article – Scott McIntosh of NCAR and Phil Scherrer of Stanford University. Both have made presentations at SARA Western Conferences)

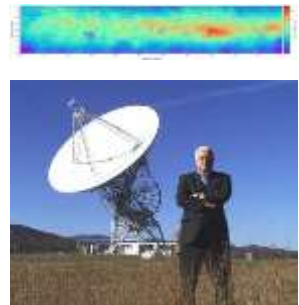

University of Alaska Fairbanks – Geophysical Institute ~ *NASA and HAARP conclude asteroid experiment:*  
<https://uaf.edu/news/nasa-and-haarp-conclude-asteroid-experiment.php>



EDN ~ *Project Diana bounces radio waves off moon, January 10, 1946:*  
<https://www.edn.com/project-diana-bounces-radio-waves-off-moon-january-10-1946/>

RadioJove Bulletin for January 2023: <https://radiojove.gsfc.nasa.gov/newsletters/2023Jan/>

Universe Today ~ *Astronomers Used a Fast Radio Burst to Probe the Structure of the Milky Way:* <https://www.universetoday.com/159579/astronomers-used-a-fast-radio-burst-to-probe-the-structure-of-the-milky-way/>

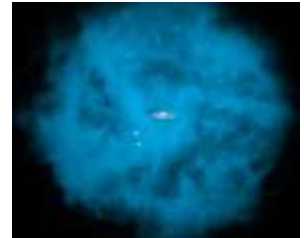

Universe Today ~ *Astronomers use the World's Biggest Radio Telescope to map new Features of the Milky Way:* <https://www.universetoday.com/159530/astronomers-use-the-worlds-biggest-radio-telescope-to-map-new-features-of-the-milky-way/>



CALLISTO Solar Radio Spectrometer Network ~ *Callisto on Artemis? You be the judge (above):*

Green Bank Observatory ~ *Planetary Defense & Science Will Advance With New Radar on Green Bank Telescope:*  
<https://greenbankobservatory.org/planetary-defense-science-will-advance-with-new-radar-on-green-bank-telescope/>

NASA ~ *Great Observatory for Long Wavelengths (GO-LoW):*



[https://www.nasa.gov/directorates/spacetechniac/2023/Great\\_Observatory\\_for\\_Long\\_Wavelengths/](https://www.nasa.gov/directorates/spacetechniac/2023/Great_Observatory_for_Long_Wavelengths/)

ArXiv ~ *Focused Space Weather Strategy for Securing Earth, and Human Exploration of the Moon and Mars:* <https://arxiv.org/abs/2301.04136> (This white paper recognizes gaps in observations that will, when addressed, much improve solar radiation hazard and geomagnetic storm forecasting. Radiation forecasting depends on observations of the entire "Solar Radiation Hemisphere" that we will define. Mars exploration needs strategic placement of radiation-relevant observations. We also suggest an orbital solution that will improve geomagnetic storm forecasting through improved in situ and solar/heliospheric remote sensing.)

History of Geo- and Space Sciences ~

- ⚙ *History of the Potsdam, Seddin and Niemeck Geomagnetic Observatories – Second Part: Seddin:* <https://hgss.copernicus.org/preprints/hgss-2023-2/>
- ⚙ *Historical geomagnetic observations from Prague Observatory (since 1839) and their contribution to geomagnetic research:* <https://hgss.copernicus.org/preprints/hgss-2022-13/>
- ⚙ *History of EISCAT – Part 6: The participation of Japan in the EISCAT Scientific Association:* <https://hgss.copernicus.org/preprints/hgss-2023-1/>

Hey, Mac – Whew! I was really sweatin’ that one out: Quanta Magazine ~ *Standard Model of Cosmology Survives a Telescope’s Surprising Finds:* <https://www.quantamagazine.org/standard-model-of-cosmology-survives-jwsts-surprising-finds-20230120/>

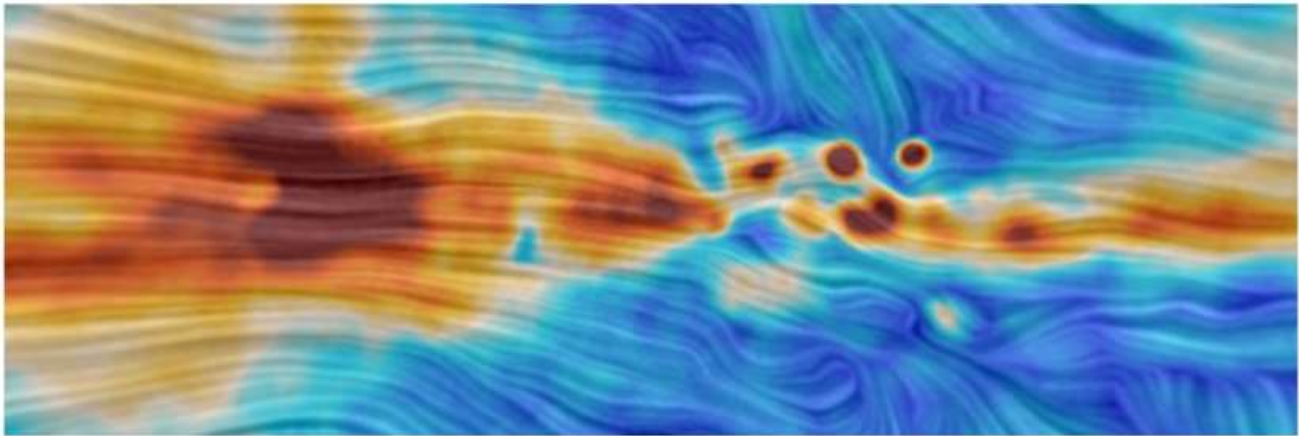

Universe Today ~ *You’re Looking at a Map of the Milky Way’s Magnetic Field (above):* <https://www.universetoday.com/159676/youre-looking-at-a-map-of-the-milky-ways-magnetic-field/>

Youtube video ~ *I took a ride on a moving radio telescope (The Parkes Radio Telescope, Murriyang, part of CSIRO, is one of the most famous telescopes in the world: and it's got a unique way of getting equipment up and down from the central section. More info: <https://www.csiro.au/en/about/facilities-collections/ATNF/Parkes-radio-telescope> ): <https://www.youtube.com/watch?v=6o38C-ultvw&t=315s>*



Square Kilometer Array Observatory ~ *Contact 12, This special issue of the SKAO’s magazine celebrates a historic moment: the start of construction at the SKA telescope sites in Australia and South Africa in December 2022. Read about the intense logistical planning behind the ceremonies, the pivotal role of local communities, and much more, including news from the SKA pathfinder telescopes, events, and more...:* [https://issuu.com/ska\\_telescope/docs/contact\\_12](https://issuu.com/ska_telescope/docs/contact_12)

Signal Integrity Journal ~ *Seven Habits of Successful 2-Layer Board Designers*:  
<https://www.signalintegrityjournal.com/blogs/12-fundamentals/post/1207-seven-habits-of-successful-2-layer-board-designers>

ABR Industries ~ *Cleaning RF Connectors*: <https://abrind.com/cleaning-rf-connectors/>

EEWeb ~ *Digital Electronics Course*:

- ⚙ Part 1: Binary Logic and Signals: <https://www.eeweb.com/digital-electronics-course-part-1-binary-logic-and-signals/>
- ⚙ Part 2: digital vs analog: <https://www.eeweb.com/digital-electronics-course-part-2-digital-vs-analog/>
- ⚙ Part 3: Numbering Functions: <https://www.eeweb.com/digital-electronics-course-part-3-numbering-systems/>
- ⚙ Part 4: Boolean Algebra and Boolean Functions: <https://www.eeweb.com/digital-electronics-course-part-4-boolean-algebra-and-boolean-functions/>

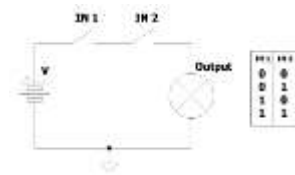
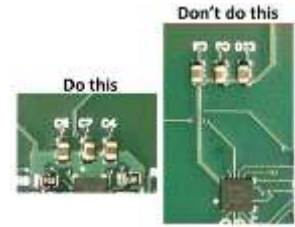

ArXiv ~ *A targeted search for repeating fast radio bursts with the MWA*: <https://arxiv.org/abs/2211.11945>

ArXiv ~ *Power-law distribution and scale-invariant structure from the first CHIME/FRB Fast Radio Burst catalog*:  
<https://arxiv.org/abs/2212.05229>

All About Circuits ~ *Using the Noise Figure Metric to Analyze Noise in RF Circuits*:  
<https://www.allaboutcircuits.com/technical-articles/using-the-noise-figure-metric-to-analyze-noise-in-radio-frequency-circuits/>

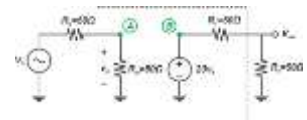

Fast Radio Bursts Symposium 2023 in Taiwan ~ 8 - 10 February 2023, hybrid, National Chung Hsing University, Taichung, Taiwan: <https://sites.google.com/phys.nchu.edu.tw/frb-taiwan-2023/about>

Electronic Design ~ *Essentials for Effective Protection Against Overvoltage Events*:  
<https://www.electronicdesign.com/power-management/whitepaper/21246147/bourns-inc-essentials-for-effective-protection-against-overvoltage-events>

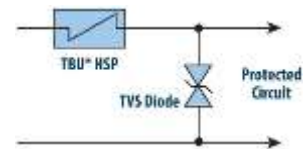

CESRA ~ *Microwave imaging of quasi-periodic pulsations at flare current sheet*:  
<https://www.astro.gla.ac.uk/users/eduard/cesra/?p=3435>

EDN ~ *A safe adjustable regulator*: <https://www.edn.com/a-safe-adjustable-regulator/>

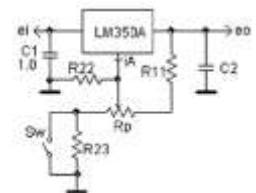

University of Oslo, Department of Physics ~ *The Five Most Likely Explanations for Long Delayed Echoes*:  
<https://www.mn.uio.no/fysikk/english/people/aca/sverre/articles/lde.html>

CESRA ~ *Radio Scintillation Observations of the Plasma Tail of Interstellar Comet 2I/Borisov*: <https://www.astro.gla.ac.uk/users/eduard/cesra/?p=3452>



All About Circuits ~ *RF Design Basics—Introduction to Transmission Lines:*

<https://www.allaboutcircuits.com/technical-articles/basic-concepts-in-rf-design-introduction-to-transmission-lines/>

ArXiv ~ *Could Fast Radio Bursts Be Standard Candles?:* <https://arxiv.org/abs/2301.08194>

ArXiv ~ *PODIUM:A Pulsar Navigation Unit for Science Missions:* <https://arxiv.org/abs/2301.08744>

ArXiv ~ *Multibeam Blind Search of Targeted SETI Observations toward 33 Exoplanet Systems with FAST:*  
<https://arxiv.org/abs/2301.10890>

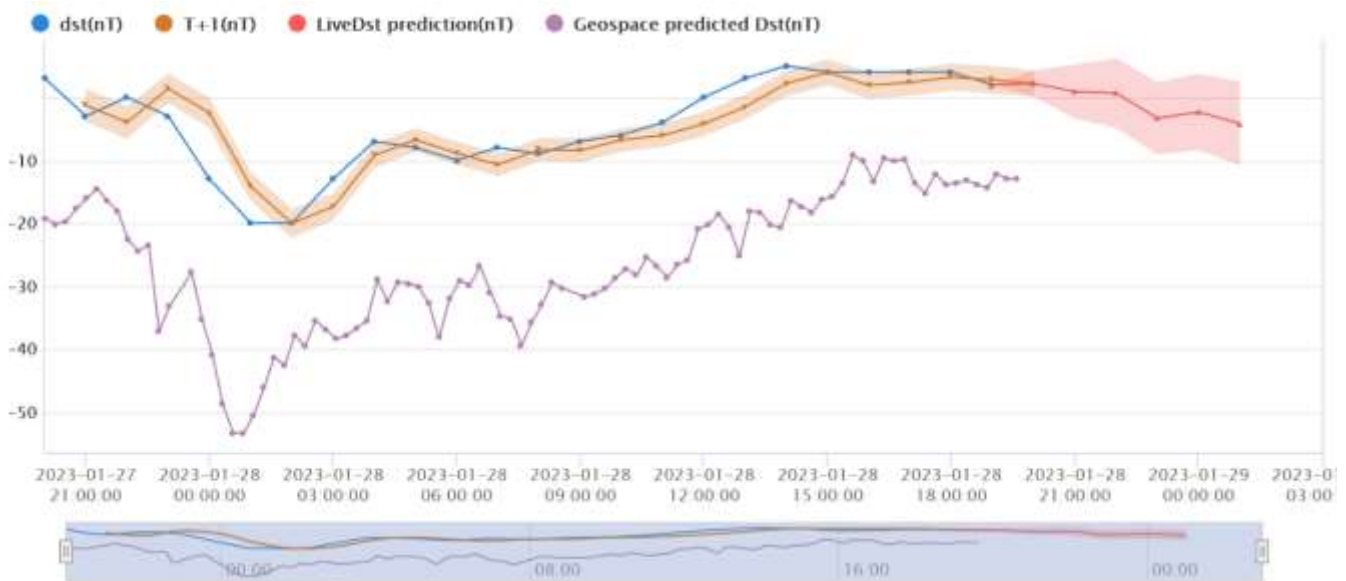

LiveDst ~ *New Real-time Dst Forecasting Model:* <https://swx-trec.com/dst/>

Epson ~ *Get this glossary for 19 timing terms to know:*



<https://forms.goepson.com/webmail/407272/998465392/23938b8bf9b3c2698c17b24632d7f04b148745f83cea865008b2affaaf4b8dc>

EDN ~ *Advancements in Wideband RF Receiver Signal Chain Design:*

<https://aspencore.omecl.com/portal/wts/ucmcnrmfyx4aegyDm6j7jB%7CLkbvjmze>

All About Circuits ~ *RF Design Basics: VSWR, Return Loss, and Mismatch Loss:*

<https://www.allaboutcircuits.com/technical-articles/radio-frequency-design-basics-voltage-standing-wave-ratio-return-loss-and-mismatch-loss/>

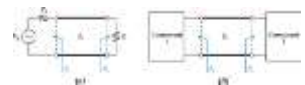



The Orange Book of Knowledge (of RF/Microwave Instrumentation): <https://arworld.us/orange-book-request/>

Basics of Radio Astronomy: [https://www2.jpl.nasa.gov/radioastronomy/radioastronomy\\_all.pdf](https://www2.jpl.nasa.gov/radioastronomy/radioastronomy_all.pdf)

Modern Antenna Design: <https://www.radio-astronomy.org/library/Antenna-design.pdf>

The Scientist and Engineer's Guide to Digital Signal Processing:  
<http://www.dspguide.com/pdfbook.htm>

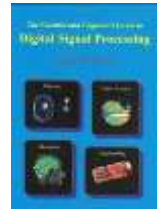

## Announcements (January-February 2023)



National Geospatial-Intelligence  
Agency (NGA)

World Magnetic  
Model (WMM)

NOAA Geomagnetic  
Data & Information

Dear World Magnetic Model users,

This is a message from NOAA's National Centers for Environmental Information. We are excited to announce the release of the "State of the Geomagnetic Field, December 2022" report. In this report, the performance of the World Magnetic Model 2020 (WMM2020) was assessed by comparing its predictions at 2023-01-01 with that of a more recent model inferred from data collected by the European Space Agency Swarm satellites until September 2022. For all magnetic field components, the WMM2020 global root-mean-square error increased by less than 5% over the past three years and remained well below the maximum error allowed by the U.S. Department of Defense WMM specification. The report also includes an assessment of the WMM secular variation, descriptions of noteworthy changes in the Earth's main magnetic field, including magnetic pole drifts and the deepening of the South Atlantic Anomaly and an assessment of the impact of strong to severe geomagnetic storms on WMM performance. The complete report can be accessed [here](#).

We plan to update this report on an annual basis, except for the years when we release a new World Magnetic Model. Note that we did not update the World Magnetic Model. No action is required at this point of time to update WMM in your system. The next regular update of WMM will happen in December 2024. If you have any questions, please contact [geomag.models@noaa.gov](mailto:geomag.models@noaa.gov).

---

INTERNATIONAL EARTH ROTATION AND REFERENCE SYSTEMS SERVICE (IERS)

SERVICE INTERNATIONAL DE LA ROTATION TERRESTRE ET DES SYSTEMES DE REFERENCE

SERVICE DE LA ROTATION TERRESTRE DE L'IERS, OBSERVATOIRE DE PARIS, 61, Av. de l'Observatoire 75014 PARIS (France), Tel.: +33 1 40 51 23 35; e-mail: [services.iers@obspm.fr](mailto:services.iers@obspm.fr), <http://hpiers.obspm.fr/eop-pc>

Paris, 09 January 2023

### **Bulletin C 65**

To authorities responsible for the measurement and distribution of time

INFORMATION ON UTC - TAI

NO leap second will be introduced at the end of June 2023. The difference between Coordinated Universal Time UTC and the International Atomic Time TAI is: from 2017 January 1, 0h UTC, until further notice : UTC-TAI = -37 s

Leap seconds can be introduced in UTC at the end of the months of December or June, depending on the evolution of UT1-TAI. Bulletin C is mailed every six months, either to announce a time step in UTC, or to confirm that there will be no time step at the next possible date.

Christian BIZOUARD, Director, Earth Orientation Center of IERS, Observatoire de Paris, France

## Earth rotation acceleration: Length of Day faster than 86400s

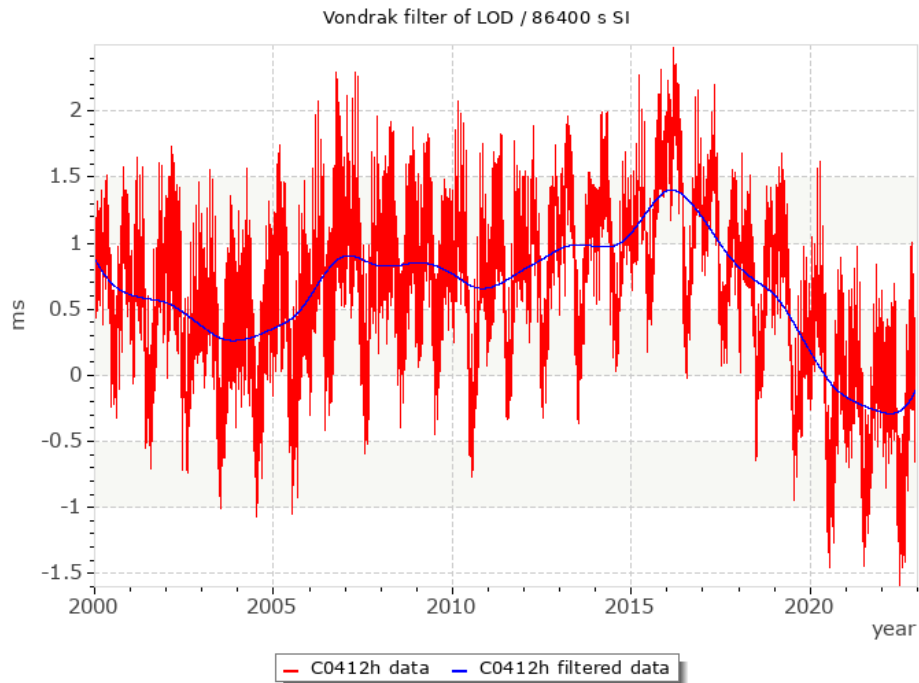

### [URSI GASS 2023 - Session G05 - Advances in Irregularities and Scintillation Studies](#)

From: Kshitija Deshpande (deshpank@erau.edu)

This is a reminder about the call for papers for the URSI 2023 General Assembly and Scientific Symposium (Sapporo, 19-26 August 2023) that is open until 25 January 2023 [<https://www.ursi-gass2023.jp/>].

Please consider submitting a paper to our Session G05- Advances in Irregularities and Scintillation Studies

The formation of ionospheric irregularities results from dynamical processes in the ionosphere, including transport processes, instabilities, and turbulence, being driven, and modulated by Space Weather phenomena and by the forcing from the neutral atmosphere. Ionospheric irregularities affect radio waves' propagation (e.g., scintillation), posing a threat to modern radio systems. Among these are Global Navigation Satellite Systems (GNSS) critical applications, for which accuracy, availability, continuity, and integrity are mandatory, and HF/VHF/UHF radio communications that exploit reflection and refraction by the ionosphere. This session emphasizes the latest developments in modeling and diagnostic measurements of driving processes, dynamics, and morphology of ionospheric irregularities. Papers that analyze scintillation effects on satellite-based communication, navigation, Synthetic Aperture Radar (SAR), and other systems at low and high latitudes are encouraged. The scope of this session also includes new developments in the theory of scintillation, statistical

studies of scintillations, multi-frequency studies and multi-technique observations of irregularities, including in situ observations, relevant to the possible prediction of scintillations.

Please submit your abstract to our session by following this link: [https://www.ursi-gass2023.jp/paper\\_submission.html](https://www.ursi-gass2023.jp/paper_submission.html).

Luca Spogli, Yuichi Otsuka, Kshitija Deshpande, P. T. Jayachandran

---



Dear CESRA Colleagues,

I am pleased to announce that the next CESRA workshop will be hosted by the University of Hertfordshire, located in Hatfield, just outside Greater London, UK. For additional details, please see the webpage <https://star.herts.ac.uk/cesra/>. The workshop will be July 3-7, 2023 and the registration/abstract submission will open soon.

CESRA2023 Workshop will feature presentations and discussions of observations, modelling and theory related to

- ⚙ Solar flares, coronal mass ejections, active regions, heliosphere and space weather
- ⚙ Particle acceleration and transport in the solar corona and heliosphere
- ⚙ Radio emission processes and radio wave propagation at the Sun and heliosphere
- ⚙ Multi-wavelength (including X-ray, EUV, etc) and in-situ observations of the Sun and the heliosphere

Please put the dates into your calendars!

Eduard Kontar, On Behalf of CESRA2023 SOC

---

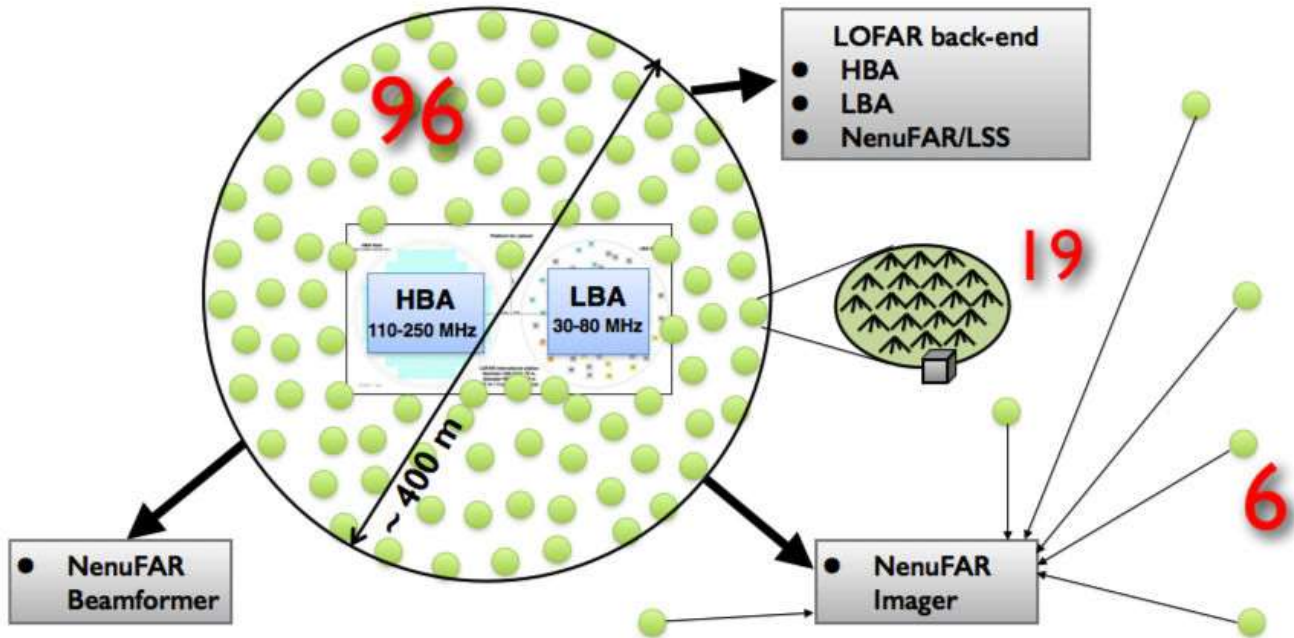

NenuFAR Open Time Cycle #2: call for proposals

Located on the site of the Nançay Radio Observatory in France, NenuFAR is a very large low-frequency radio telescope, which is among the most powerful in the world in its frequency range between 10 MHz and 85 MHz. This range corresponds to the lowest spectral “window” in which we can observe with radio telescopes from the surface of the Earth. We invite the worldwide community to apply for observing with NenuFAR during Cycle #2.

Cycle #2: 1st June 2023 to 30 November 2023

Submission deadline: Wednesday, March 15, 12 UT

Proposal documents are available here: <https://nenufar.obs-nancay.fr/en/astronomer/>

The NenuFAR Science Committee

Philippe ZARKA - LESIA, UMR CNRS 8109, Observatoire de Paris, 92195 MEUDON, France

Tel: +33(0)145077663, Email: [Philippe.Zarka@obspm.fr](mailto:Philippe.Zarka@obspm.fr)



SCIENTIFIC FRONTIERS AND SYNERGIES FOR THE DSA-2000 RADIO CAMERA

**March 20 - 22, 2023 - Pasadena, California USA**

The next decade will see the emergence of new multi-wavelength All-Sky Surveys, such as Rubin/LSST, Sphere-X, WFIRST, EUCLID, and PFS that are poised to revolutionize a broad range of astrophysical topics. The [DSA-2000 radio camera](#), commencing construction in 2024, will provide a sensitive all-sky radio component to these surveys. It will consist of 2,000 x 5-m dishes operating between 0.7-2 GHz and will operate as a radio camera, providing the community with uniquely accessible images and data cubes rather than visibility data products. The DSA-2000 images will have few-arcsecond resolution, sub-microJansky sensitivity, and dynamic ranges >100,000 across the entire sky. Through a sixteen-epoch all-sky survey, the DSA-2000 will map, catalog, characterize and monitor over a billion radio sources with full polarization, with detailed HI observations to  $z=1$ . We will discuss frontier topics that this new generation of surveys will provide, including unprecedented observations of the static sky of nearby and distant galaxies, as well as the transient sky. The DSA-2000 will be a leading instrument for multi-messenger astronomy through the discovery and characterization of the electromagnetic counterparts to gravitational wave (GW) sources detected by LIGO-Virgo-KAGRA and by timing a suite of millisecond pulsars to enable the first detections of nanoHertz GWs from individual binary supermassive black holes (SMBHs) in galaxy mergers. In addition, time-domain analyses of DSA-2000 survey data, including commensal searches for FRBs and pulsars, will deliver transformational samples of events that populate the dynamic radio sky. Registration: <https://www.deepsynoptic.org/registration>

---



**April 17-21, 2023**

Space Weather Workshop is an annual conference that brings industry, academia, and government agencies together in a lively dialog about space weather. What began in 1996 as a conference for the space weather user community, Space Weather Workshop has evolved into the Nation's leading conference on all issues relating to space weather.

The conference addresses the remarkably diverse impacts of space weather on today's technology. The program highlights space weather impacts in several areas, including communications, navigation, spacecraft operations, human space exploration, aviation, space traffic coordination, and electric power. The workshop will also focus on the highest priority needs for operational services that can guide future research and new high-value capabilities that can be transitioned into operations. The conference fosters communication among researchers, space weather service providers, and users of space weather services.

Space Weather Workshop is organized by the University Corporation for Atmospheric Research (UCAR) Cooperative Programs for the Advancement of Earth System Science (CPAESS), along with a community-based organizing committee and co-sponsored by the NOAA Space Weather Prediction Center, the NSF Division of Atmospheric and Geospace Sciences, and the NASA Heliophysics Division.

Workshop weblink: <https://web.cvent.com/event/955c2f5e-ee9f-4e8e-a1e6-46ea97aa48fe/summary>

Venue: Embassy Suites Boulder, 2601 Canyon Blvd, Boulder, CO 80302

---

### **Magnetosphere Online Seminar Series**

From: Kyle Murphy (magnetosphere.seminars at gmail.com)

We invite you to join us Mondays at 12 pm (EST, 5 UT) for the weekly Magnetosphere Online Seminar Series. Join the seminar via Zoom or YouTube can be found on our home page: <https://msolss.github.io/MagSeminars/> You can view the current 2023 schedule here - <https://msolss.github.io/MagSeminars/schedule.html> Add your name to the mailing list for notifications and get password here - <https://msolss.github.io/MagSeminars/mail-list.html> And see previous talks here - <https://www.youtube.com/channel/UCNIOK9mCmI3V111EHQRCuEQ>

---



**SuperSID**  
*Collaboration of Society  
of Amateur Radio  
Astronomers and  
Stanford Solar Center*



- Stanford provides data hosting, database programming, and maintains the SuperSID website
- Society of Amateur Radio Astronomers (SARA) sells the SuperSID monitors for 48 USD to amateur radio astronomers and the funds are then used to support free distribution to students all over the world (image below as of Fall 2017)
- Jonathan Pettingale at SARA is responsible for building and shipping the SuperSID monitor kits: [SuperSID@radio-astronomy.org](mailto:SuperSID@radio-astronomy.org)
- SuperSID kits may be ordered through the SARA SuperSID webpage: <http://radio-astronomy.org/node/210>
- Questions about the SuperSID project may be directed to Steve Berl at Stanford: [steveberl@gmail.com](mailto:steveberl@gmail.com)
- Jaap Akkerhuis at Stanford is responsible for the SuperSID software and SARA has provided financial support for his efforts
- SuperSID website hosted by Stanford: <http://solar-center.stanford.edu/SID/sidmonitor/>
- SuperSID database: <http://sid.stanford.edu/database-browser/>
- The data is searchable by time, station, date, and multiple plots may be placed on the same graph for comparison.



**SID Monitor  
Distribution**  
1078 instruments  
82 countries  
7 continents

Algeria - 2	Denmark - 3	Mexico - 21	Slovenia - 2
Antarctica - 1	Egypt - 3	Montenegro - 10	South Africa - 8
Australia - 7	Ethiopia - 14	Mozambique - 2	Spain - 1
Austria - 3	France - 9	Namibia - 1	Sri Lanka - 1
Azerbaijan - 2	Gabon - 1	Netherlands - 5	Sweden - 3
Bangladesh - 1	Germany - 30	New Zealand - 7	Switzerland - 4
Bhutan - 1	Greece - 7	Nigeria - 57	Taiwan - 4
Bolivia - 1	Guyana - 1	Pakistan - 4	Thailand - 5
Bosnia-Herzegovina - 2	Hungary - 1	Peru - 10	Tunisia - 9
Brazil - 11	India - 53	Philippines - 3	Turkey - 2
British Virgin Islands - 1	Indonesia - 2	Poland - 2	Uganda - 5
Bulgaria - 2	Iran - 4	Portugal - 3	UK - 32
Burkina Faso - 1	Iraq - 1	Rep of Congo - 3	Uruguay - 9
Canada - 31	Ireland - 9	Romania - 4	US Virgin Islands - 2
Chile - 1	Italy - 42	Russia - 3	USA - 491
China - 38	Kazakhstan - 25	Rwanda - 1	Uzbekistan - 2
Columbia - 9	Korea (South) - 2	S Africa - 4	Venezuela - 2
Cote d'Ivoire - 7	Lebanon - 11	Senegal - 1	Vietnam - 1
Cyprus - 1	Libya - 1	Serbia - 1	Zambia - 2
Czech Republic - 1	Malaysia - 19	Singapore - 3	
D Rep of Congo - 4	Malta - 1	Slovak Repub - 2	



For official use only  
 Monitor assigned: \_\_\_\_\_  
 Site name: \_\_\_\_\_  
 Country: \_\_\_\_\_

## SuperSID Space Weather Monitor Request Form

Your information here				
Name of site/school (if an institution):				
Choose a site name: <i>(3-6 characters) No Spaces</i>				
Primary contact person:				
Email:				
Phone(s):				
Primary Address:	Name School or Business Street Street City <span style="float: right;">State/Province</span> Country <span style="float: right;">Postal Code</span>			
Shipping address, if different:	Name School or Business Street Street City <span style="float: right;">State/Province</span> Country <span style="float: right;">Postal Code</span>			
Shipping phone number:	<table border="1" style="width: 100%; border-collapse: collapse;"> <tr> <td style="width: 33%; height: 20px;"></td> <td style="width: 33%; height: 20px;"></td> <td style="width: 33%; height: 20px;"></td> </tr> </table>			
Latitude & longitude of site:	Latitude: _____ Longitude: _____			

**I understand that neither Stanford nor the Society of Amateur Radio Astronomers is responsible for accidents or injuries related to monitor use. I will assure that a surge protector and other lightning protection devices are installed if necessary.**

**Signature:** \_\_\_\_\_ **Date:** \_\_\_\_\_

*I will need:*

What	Cost	How many?
SuperSID distribution USB Power	\$48 (assembled)	
USB Sound card 96 kHz sample rate (or provide this yourself)	\$40 (optional)	
Antenna wire (120 meters) (or you can provide this yourself)	\$23 (optional) with connectors attached and tested	
RG 58 Coax Cable (9 meters) (or provide this yourself)	\$14 (optional) with connectors attached and tested	
Shipping	US \$12 Canada & Mexico \$40 all other \$60	
	<b>TOTAL</b>	\$

\_\_\_\_\_ I have included a \$\_\_\_\_\_ check (payable to SARA)

\_\_\_\_\_ I will make payment thru [www.paypal.com](http://www.paypal.com) to [treas@radio-astronomy.org](mailto:treas@radio-astronomy.org)

or

\_\_\_\_\_ If you are a Minority-serving institution, in a Developing or economically deprived nation, and/or you are using the monitor with students for educational purposes, you may qualify for obtaining a monitor at reduced or no cost. Check here if you wish to apply for this designation. Then tell us how you want to use the SuperSID monitor. Include type of site, number of students involved, whether public or private school, grade levels, etc. and describe your program. The goal of the SuperSID project is to provide as many students with systems as possible. If you are able to pay for a system, even if you qualify for a free one, please do so and help support our goal.

---

---

---

---

For more details on the Space Weather Monitor project, see: <http://sid.stanford.edu>

To set up a SuperSID monitor you will need:

<sup>1</sup> Access to power and an antenna location that is relatively free of electric interference (could be indoors or out)

<sup>2</sup> A **PC\*\*** with the following minimal specifications:

- a. A sound card that can record (sample) up to 96 kHz, or a USB port to connect such a sound card (for North and South America)
  - i. All other countries can use AC97 sound card with 48 kHz record (sample) rate. Most computers made after 1997 will have AC97.
- b. Windows 2000 or more recent operating system
- c. 1 GHz Processor with 128 mb RAM
- d. Ethernet connection & internet browser (desirable, but not required)
- e. Standard keyboard, mouse, monitor, etc.

<sup>3</sup> An inexpensive antenna that you build yourself. You'll need about 120 meters (400 feet) of **insulated** wire. Solid wire is easier to wind than stranded. Magnet wire will work but be more fragile. You can use anything from #18 to #26 size wire. The antenna frame can be made of wood, PVC pipe, or similar materials. We'll provide instructions. You can purchase the wire from us or obtain your own.

<sup>4</sup> RG58 coax cable with a BNC connector at one end to run from the antenna to the SuperSID receiver. 9 meters is recommended, but the length will depend on where you place the antenna. You can purchase the coax from us or obtain your own.

<sup>5</sup> Surge protector and other protection against a lightning strike

---

Return this form to: [SuperSID@radio-astronomy.org](mailto:SuperSID@radio-astronomy.org)

or mail to: SARA  
Brian O'Rourke, SARA Treasurer  
337 Meadow Ridge Rd,  
Troy, VA 22974-3256

## Announcing Radio JOVE 2.0

The Radio JOVE Team



Radio JOVE students and amateur scientists from around the world observe and analyze natural radio emissions of Jupiter, the Sun, and our galaxy using their own easy to construct radio telescopes.

Our Project announces Radio JOVE 2.0, where participants assemble a 16-24 MHz radio spectrograph to observe solar, Jupiter, Galactic, and Earth-based natural radio emissions and share their observations with fellow participants.

### In the Beginning

Radio JOVE started as a NASA sponsored educational outreach project in 1999. We developed a radio telescope kit suitable for receiving signals from Jupiter, the Sun, the Galaxy, and Earth-based radio emissions. The original kit comprised a radio receiver (RJ1.1) and a dual dipole antenna for 20.1 MHz. An important goal was to teach electronic principles including how to build, solder, and assemble the radio receiver and antenna.

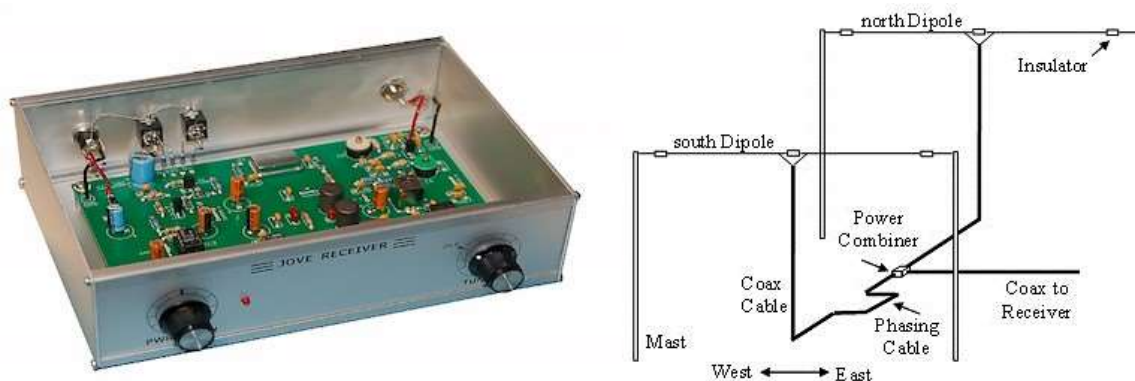

Figure 1. A Radio JOVE RJ1.1 receiver and a schematic of the dual-dipole antenna.

In addition to the hardware, three software packages were developed. These were Radio Jupiter Pro (Jupiter emission prediction program), Radio-SkyPipe (strip chart program) and Radio Sky Spectrograph (control and display of radio spectrograph data).

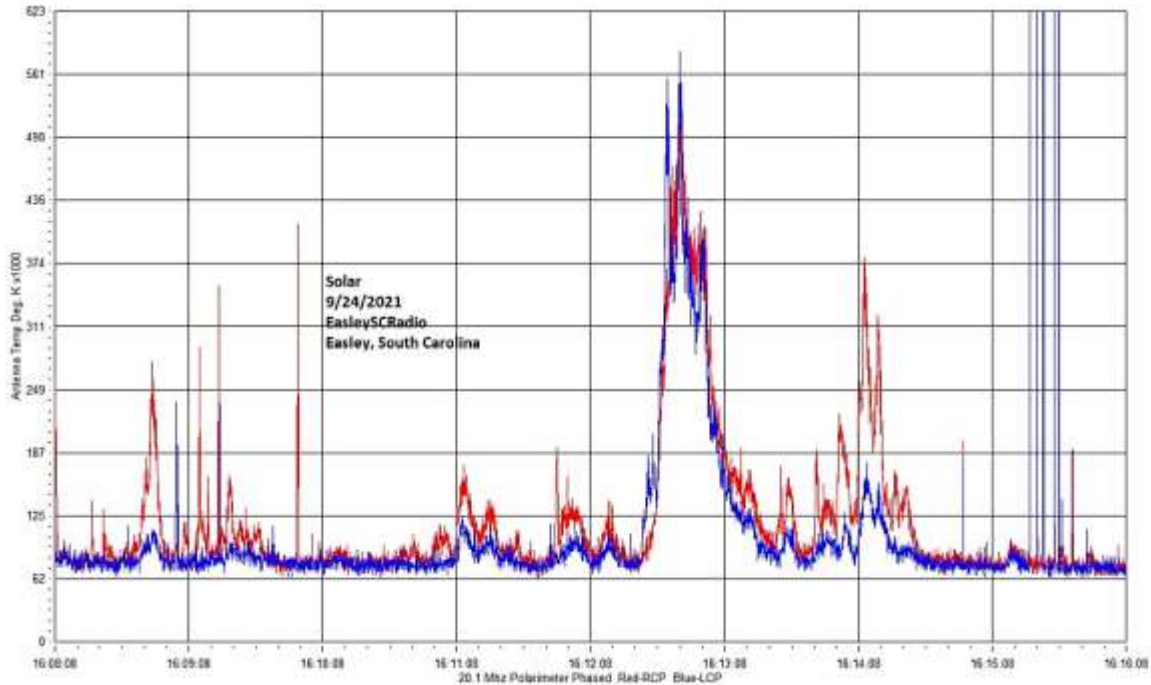

Figure 2. A SkyPipe strip chart showing multiple solar bursts using a JOVE receiver. John Cox, SC.

### The Growth of Radio JOVE

As of Autumn 2021, over 2,500 kits have been sold at cost to schools and individuals around the world. Thousands of data submissions from observers have been made to the Radio JOVE data archive.

The Radio JOVE web site has always provided a wealth of information describing observation methods and various educational materials intended to teach radio astronomy techniques and scientific methods. Biannual newsletters are produced and several telephone help sessions are held each year.

A sub-group of experienced observers known as the Spectrograph Users Group (SUG) evolved from the core JOVE group. These observers developed data collection and analysis techniques using more advanced equipment and techniques. SUG members have contributed to articles published in peer-reviewed scientific journals. This group remains active under the Radio JOVE listserv at <https://groups.io/g/radio-jove/>.

### Moving Forward with New Technology

In the past, Radio JOVE provided the hands-on experience of building a radio kit. We have many RJ1.1 receivers in operation successfully contributing scientifically valuable data. It has, however, become increasingly difficult to obtain parts for the RJ1.1 receiver kits and we therefore decided to replace the RJ1.1 receiver with a new SDR-based design for the receiver portion of our radio telescope kits. While we continue to support the hardware and software for the original RJ1.1 receivers, the only kits now available for purchase from Radio JOVE contain this newly designed system.

In recent years, new technologies have made software defined radios (SDRs) ever more affordable. These radios can operate on a single frequency like the original JOVE receiver but can also generate spectrograms which depict radio activity as a function of both time and frequency. Such displays offer new insights into our studies of the Sun, Jupiter, the Galaxy, and both natural and artificial Earth-based radio emissions.

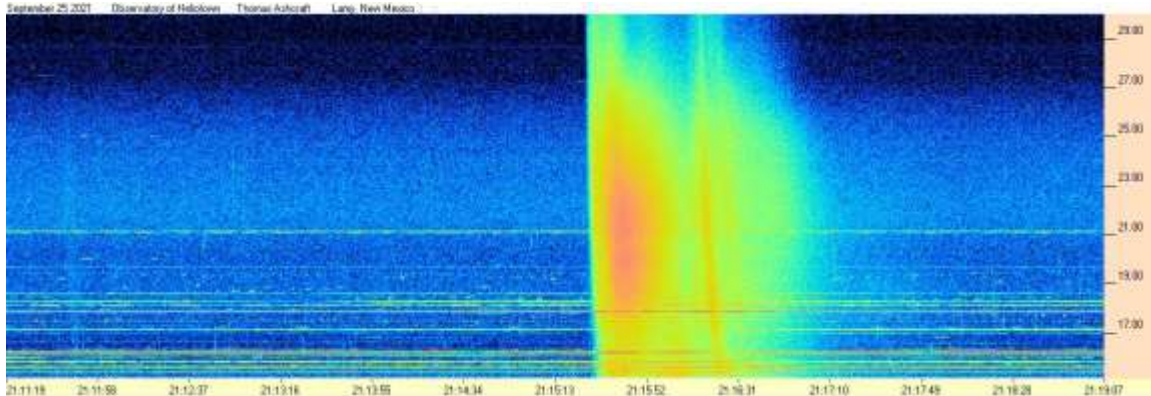

Figure 3. Radio spectrogram showing multiple solar bursts received by Tom Ashcraft in New Mexico. Horizontal scale is time, and the vertical scale is frequency. Amplitude is displayed using different colors corresponding to the strength of signals.

Radio JOVE continues to sell radio telescope packages including an antenna, receiver, and software; however, the receiver is now a commercially built SDR.



Figure 4. The JOVE team has had considerable success with the SDRPlay RSP1A unit and will provide support for using this instrument for our radio astronomy program. Not all SDR types can be supported, but it is our intent to provide support for some other SDRs as they become available during this period of rapid SDR development.

It continues to be our goal to introduce new observers to the scientific method and help them experience the thrill of receiving cosmic radio signals. Through a series of educational training modules and observing and analysis projects we aim to guide new observers to levels where they can contribute to Citizen Science projects.

We continue to support our large user base that uses JOVE RJ1.1 receivers – both in terms of technical support for the receivers but also with new and exciting observing projects for both RJ1.1 and SDR users.

We welcome both new and experienced observers to the JOVE 2.0 program as we share the excitement of receiving, studying, and understanding radio signals from our corner of the galaxy.

Please see the Radio JOVE web site at <https://radiojove.gsfc.nasa.gov> for more information.



## RADIO JOVE 2.0 RADIO TELESCOPE KIT ORDER FORM

Order Online using PayPal™

\* \* \* Please allow 2 to 3 weeks for delivery. \* \* \*

**IMPORTANT:** Before you order the Jove receiver kit and/or the antenna kit, we suggest that you read the on-line manuals. You will need to provide additional materials and tools to complete the antenna. The cost of additional materials for the antenna support structure (masts, etc.) may be in the range of US\$75 to US\$100. Also note that the optimal antenna height can be up to 20ft, depending upon your latitude.

<p><b>Item # RJK2u</b> – Complete 2.0 Kit: Receiver + Unbuilt Antenna Kit + Software</p> <p>This kit includes an SDRplay RSP1A, USB Cable, SMA/BNC cable, F-adapter, unbuilt Antenna Kit (RJA), printed assembly manuals, and Radio-Sky Spectrograph (RSS) software.</p> <p>Note: Kit does not include antenna support structure.</p> <p><b>Price: \$215 + Shipping (See reverse for shipping)</b></p>	<p><b>Item # RJK2p</b> – Complete 2.0 Kit: Receiver + Professionally Built Antenna Kit + Software</p> <p>This kit includes an SDRplay RSP1A, USB Cable, SMA/BNC cable, F-adapter, Professionally Built Antenna Kit (RJA2), printed assembly manuals, and Radio-Sky Spectrograph (RSS) software.</p> <p>Note: Kit does not include antenna support structure.</p> <p><b>Price: \$384 + Shipping (See reverse for shipping)</b></p>
<p><b>Item # RJA</b> – Unbuilt Antenna Kit</p> <p>The RJA Radio JOVE Antenna Kit includes a printed construction manual, stranded copper easy-to-solder antenna wire, ceramic insulators, RG-59 easy-to-solder coax cable, screw-on Fconnectors, and a power combiner.</p> <p>Note: Kit does not include antenna support structure. Assembly requires a soldering gun and other tools.</p> <p><b>Price: \$90 + Shipping (See reverse for shipping)</b></p>	<p><b>Item # RJA2</b> – Professionally Built Antenna Kit</p> <p>The RJA2 Radio JOVE Antenna Kit includes a printed installation manual, two professionally assembled dipole antennas constructed of #14 Copperweld wire with Budwig center insulators and center support rope attachment points, high quality RG-6 coax with pre-installed commercial grade connectors, and a power combiner.</p> <p>Note: Kit does not include antenna support structure.</p> <p><b>Price: \$249 + Shipping (See reverse for shipping)</b></p>
<p><b>Item # LTJ2</b> – Listening to Jupiter, 2nd Ed. by R. S. Flagg</p> <p>PDF download of Richard Flagg's book "Listening to Jupiter, 2nd Ed., 2005". The file is downloaded from a secure website.</p> <p><b>Price: \$10 + \$0 shipping (PDF file download)</b></p>	<p><b>Item # RJR2</b> – Radio JOVE 2.0 Receiver-Only Kit</p> <p>This kit includes one SDRplay RSP1A SDR receiver, USB Cable, SMA/BNC cable, and F-adapter, printed assembly manuals, and Radio-Sky Spectrograph (RSS) software.</p> <p><b>Price: \$135 + Shipping (See reverse for shipping)</b></p>

# RADIO JOVE 2.0 RADIO TELESCOPE KIT ORDER FORM (continued)

Order Online at [https://radiojove.net/kit/order\\_form.html](https://radiojove.net/kit/order_form.html) OR  
 Complete this form and mail with payment

Payment may be made by Credit Card via PayPal™, U.S. Check, U.S. Money Order, International Money Order in U.S. funds drawn on a U.S. bank, or Western Union Money Transfer made payable to **The Radio JOVE Project**. No bank-to-bank wire transfers are accepted. Purchase Orders are accepted from U.S. Institutions.

**Send to:** The Radio JOVE Project  
 1301 East Main St  
 MTSU Box 412  
 Murfreesboro, TN 37132, USA  
 email: [chiggins@mtsu.edu](mailto:chiggins@mtsu.edu)  
 FEIN: 20-5239863

Item	Description	Quantity	Item Price	Shipping (see below)	Subtotal
RJK2u	Complete Radio JOVE 2.0 Kit Receiver + unbuilt Antenna		\$215		
RJK2p	Complete Radio JOVE 2.0 Kit Receiver + Professionally Built Antenna		\$384		
RJA2	Professionally Built Antenna-Only Kit		\$249		
RJA	Unbuilt Antenna-Only Kit		\$90		
RJR2	Receiver-Only Kit		\$135		
LTJ2	Listening to Jupiter, 2 <sup>nd</sup> Ed., by R.S. Flagg (PDF download)		\$10	\$0	
<b>Total:</b>					

**Shipping Fees for Radio JOVE:** We ship all packages using USPS Priority Mail flat rate boxes.

U.S.A.: \$17.00  
 Canada: \$57.00  
 All Other International Shipping: \$85.00

**Ship to:** (Please print clearly)

Name: \_\_\_\_\_  
 Address: \_\_\_\_\_  
 City, State, Postal Code: \_\_\_\_\_  
 Province, Country: \_\_\_\_\_  
 Email: \_\_\_\_\_

Visit the Radio JOVE web site and fill out the team application form at [https://radiojove.net/sign\\_up\\_form.php](https://radiojove.net/sign_up_form.php) even if you are just an interested individual so that you can receive important information about kit updates, online services, and activities within the project as they occur!





**The British Astronomical Association**  
A company limited by guarantee

Registered Charity No. 210769

Burlington House, Piccadilly, London, W1J 0DU

Telephone: 020 7734 4145

Fax No.: 020 7439 4629

Email: [office@britastro.org](mailto:office@britastro.org)

Website: [www.britastro.org](http://www.britastro.org)



Please send questions, reports and observations to John Cook: [jacook@jacook.plus.com](mailto:jacook@jacook.plus.com)

## John Cook's VLF Report

BAA Radio Astronomy Section, Director: Paul Hearn

RADIO SKY NEWS

2022 November

### VLF SID OBSERVATIONS

Solar activity has been much lower than in October, with a total of 35 SIDs recorded. Signals have also been very unstable making the smaller flares difficult to detect in the noise. 23.4kHz seems to have been particularly badly affected, while the more northerly / southerly paths have been less affected. Paul Hyde's recording from the 13<sup>th</sup> shows the problem well:

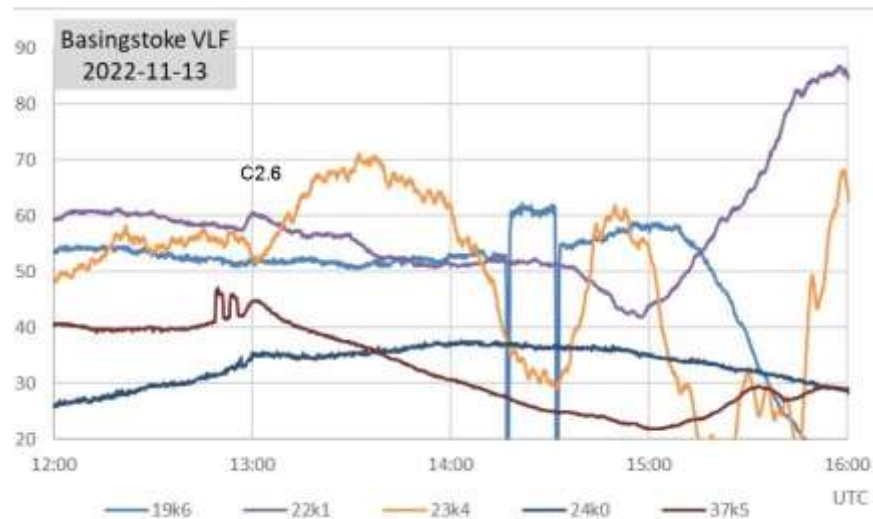

The C2.6 flare stands out well at 22.1 and 37.5kHz, despite some glitches from Grindavik. 23.4kHz shows a good SID, but it is not that obvious on the very unstable signal. It also shows the very early sunset features on the easterly path. Activity on the 11<sup>th</sup> was rather stronger, and so the SIDs are a little easier to see on Paul's recording on the next page. 19.6kHz from Skelton, just a few miles away from the Anthorn site, has not responded as well on either chart, and 23.4kHz shows much the same instability. The M1.2 flare does stand out on most signals, but not 20.3kHz, from Italy. The much smaller C3.6 flare during the M1.2 decay is also well recorded. Both flares were from the same active region.

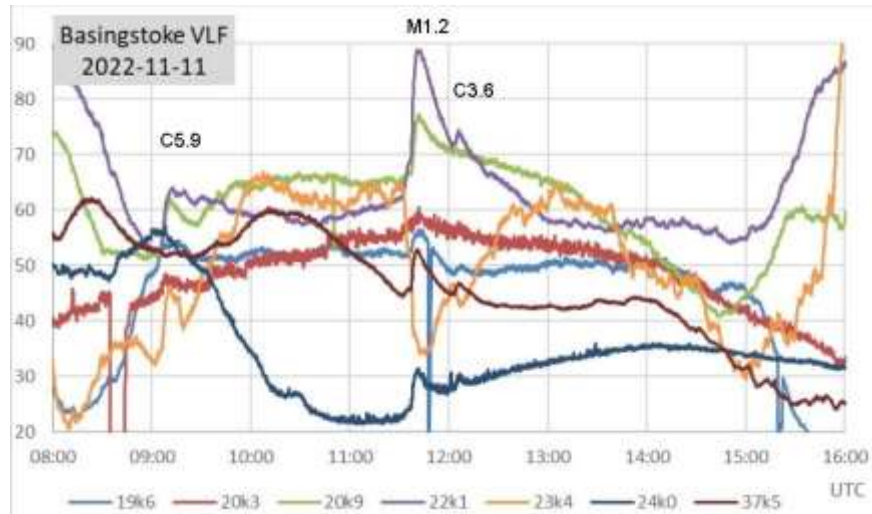

Mark Edwards noted some strong asymmetry in the diurnal curves, particularly on the 8<sup>th</sup>:

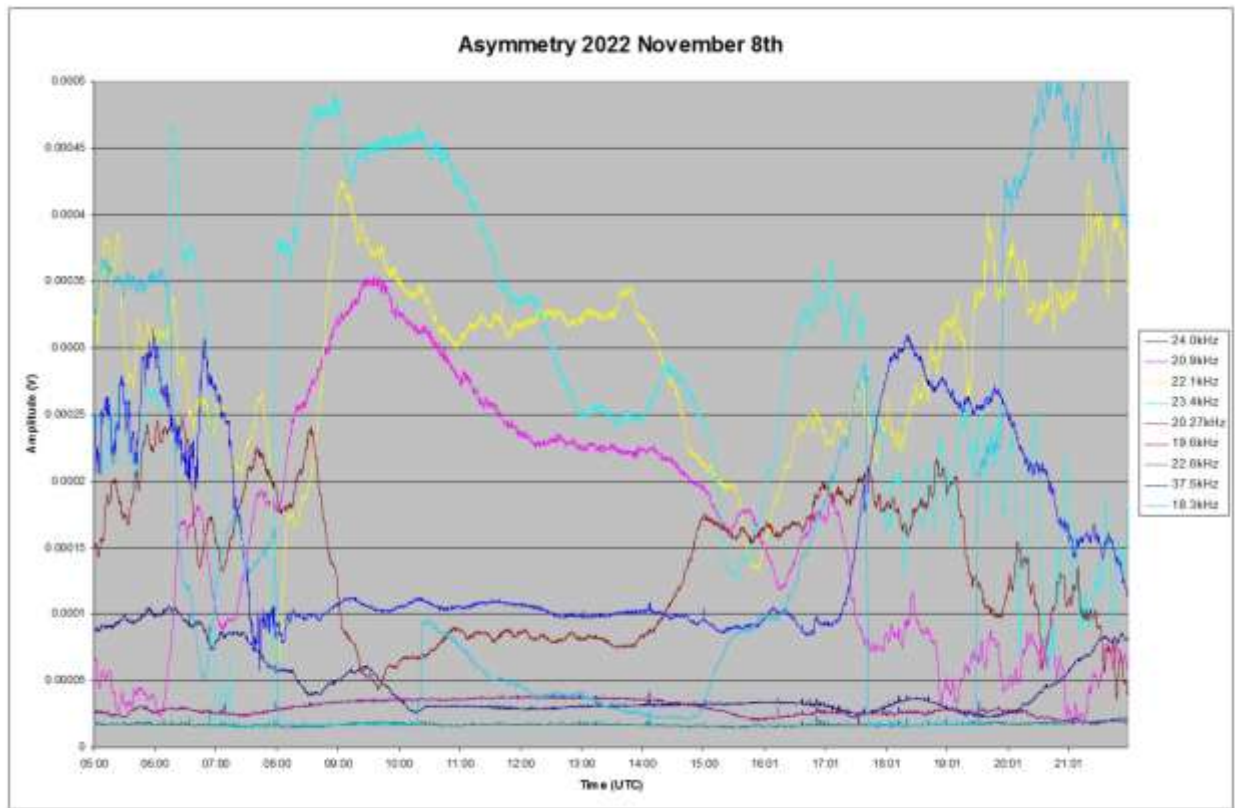

This shows particularly at 23.4kHz (light blue), 22.1kHz (yellow), and 20.9kHz (pink), with an inverted asymmetry at 19.6kHz (brown). My own 23.4kHz recordings also show this asymmetry at 23.4kHz on the 8<sup>th</sup>, and from the 19<sup>th</sup> to the 21<sup>st</sup>. These are mostly days of very low solar activity, although there was an M1.6 in the early afternoon of the 19<sup>th</sup>. This flare shows well at 20.9kHz in the recording by Mark Prescott, although much less asymmetry in the diurnal curve.

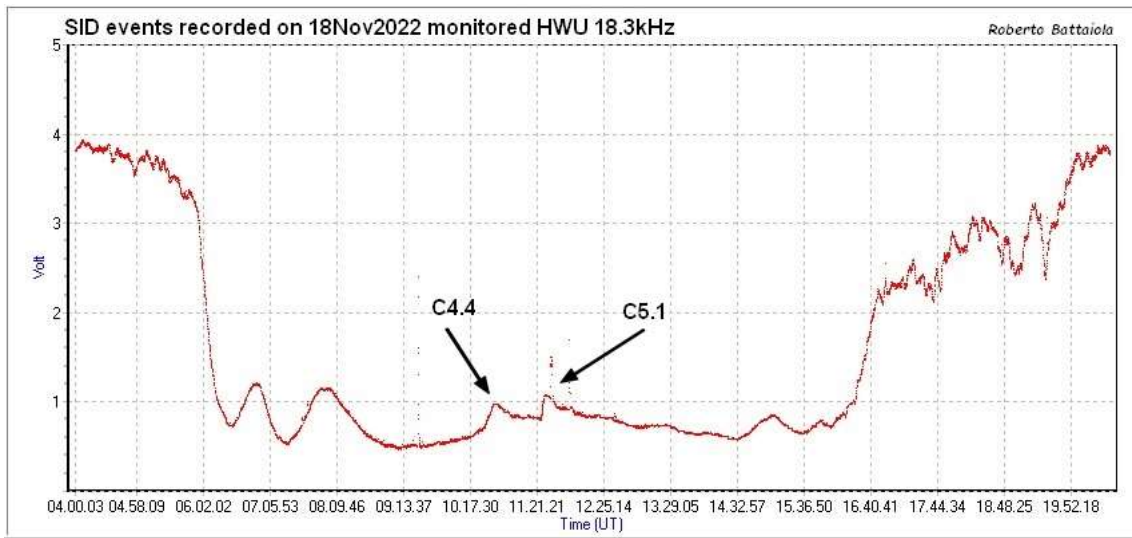
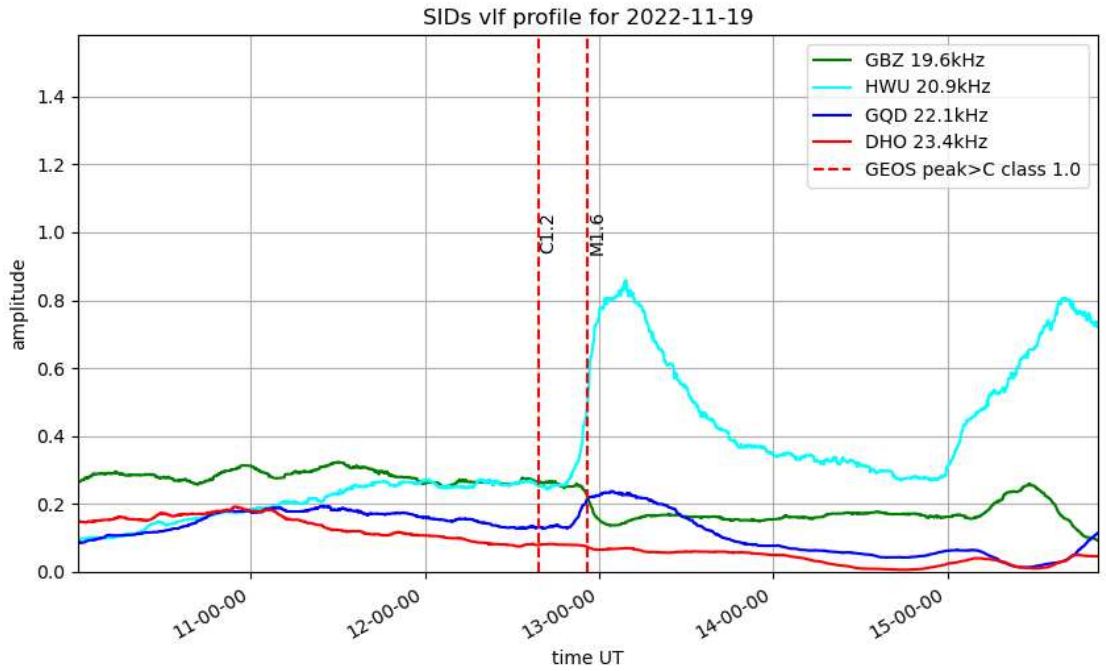

Two much smaller flares have produced very clear SIDs at 18.3kHz in this recording by Roberto Battaiola on the 18<sup>th</sup>.

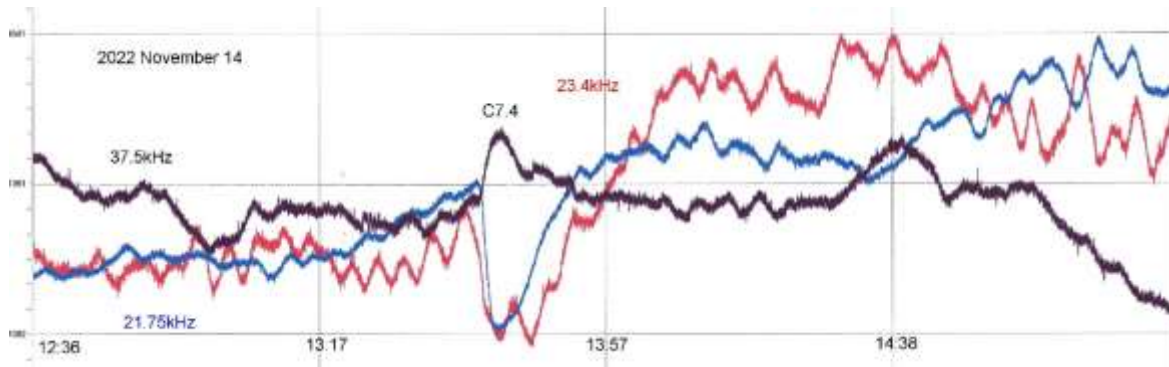

Colin Clements' recording from the 14<sup>th</sup> shows the C7.4 flare, once again on very unstable signals. 23.4kHz also again seems to be the worst affected.

### MAGNETIC OBSERVATIONS

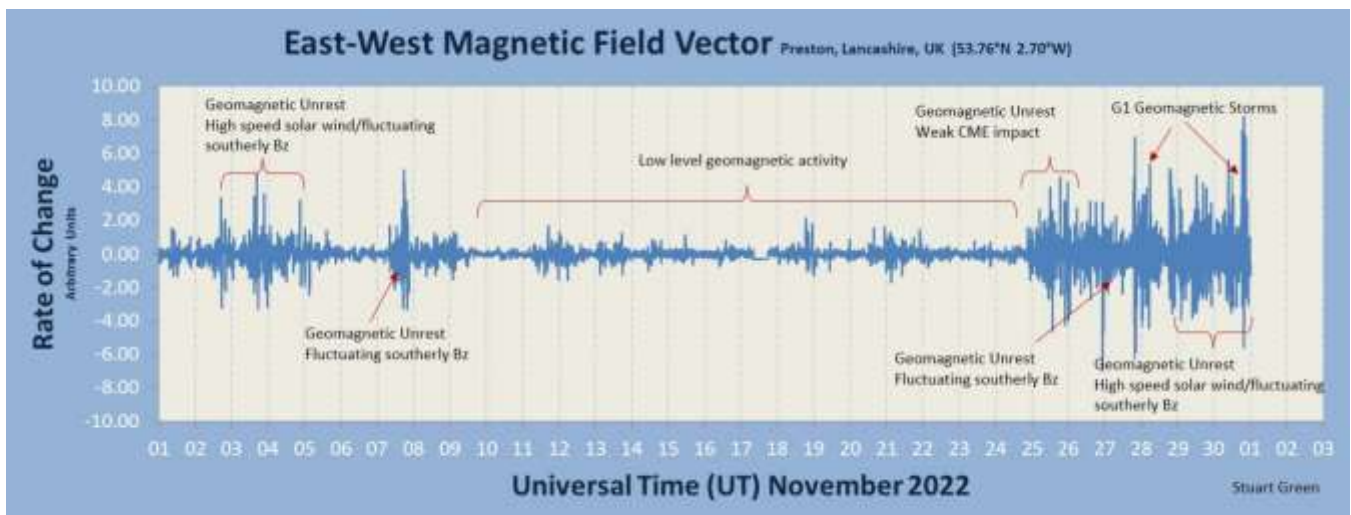

Stuart Green's monthly summary shows a very quiet magnetosphere through most of November, starting with some weak solar wind effects and ending with an extended active period during the last week.

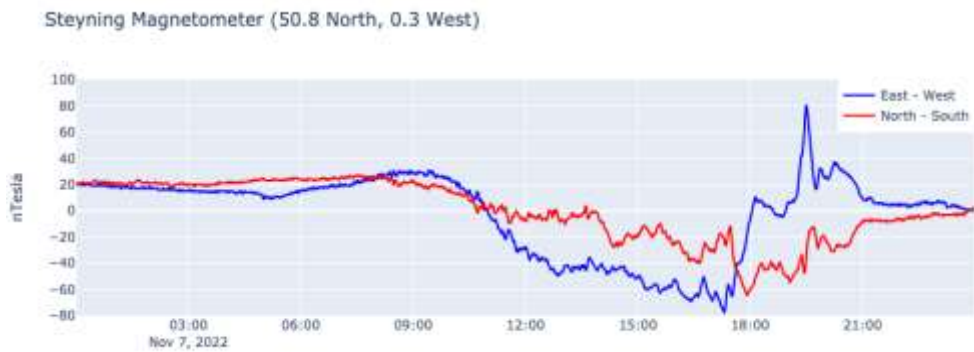
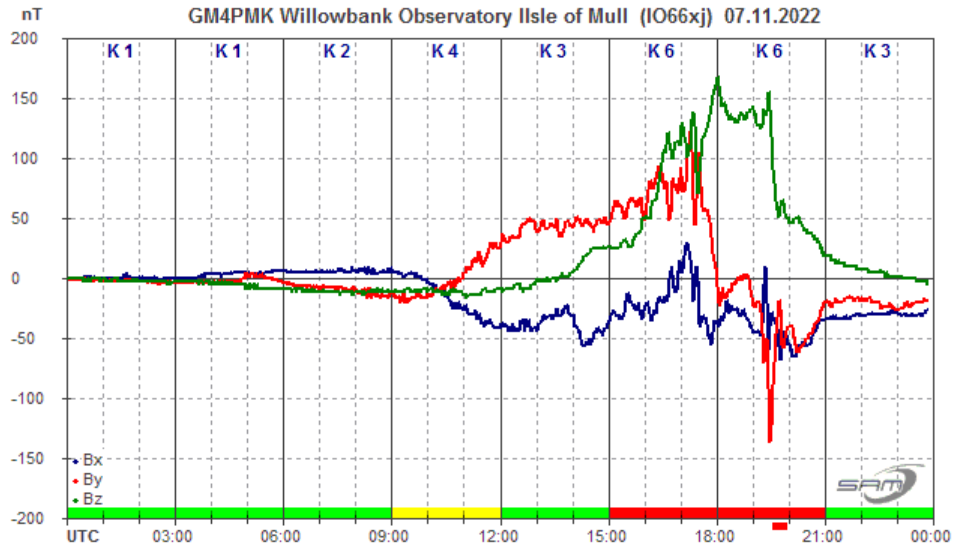

The most active magnetic disturbance was recorded in the afternoon and evening of the 7<sup>th</sup>, shown in the top recording by Roger Blackwell, and the lower chart by Nick Quinn. The sensitivities of these two sensors have opposite polarities, but the dominant features are clear in both, with a strong transient at 19:30UT. The source of the disturbance appears to be a brief period of fast solar wind, lasting just 12 hours.

There were a number of CMEs associated with the stronger flares, but they were all from active regions near the solar limb, and so had limited effect on our magnetic field. Stuart Green's summary chart indicates a weak CME impact around the 25<sup>th</sup>/26<sup>th</sup>, although its source is not clear. Most of this disturbance seems to have been from a coronal hole high speed wind.

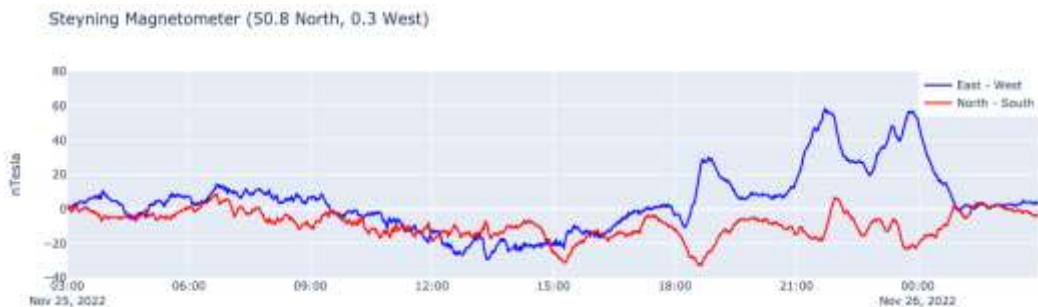

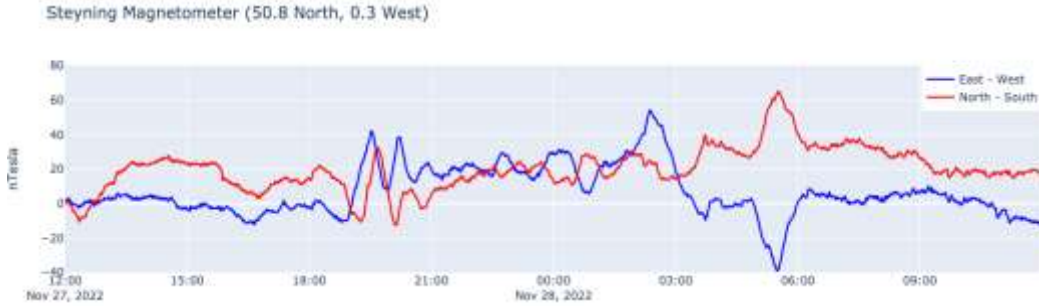

Nick Quinn’s recordings from the 25<sup>th</sup> and 27<sup>th</sup>/28<sup>th</sup> show some of this activity. There is no clear sign of a CME impact, indicating that it may have been just a glancing blow.

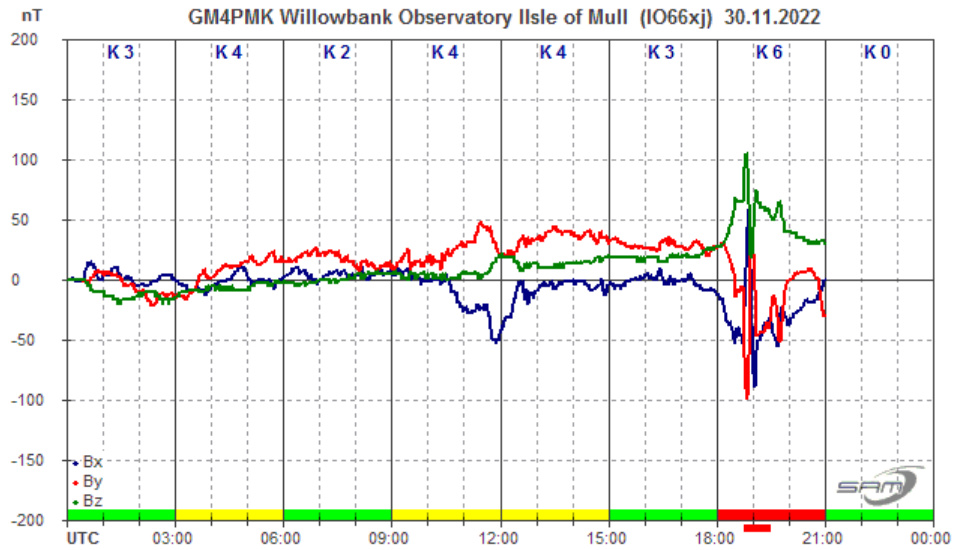

Roger Blackwell’s recording from the 30<sup>th</sup> shows further high-speed wind effects building up in the evening of the 30<sup>th</sup>, although his recording terminated early for some reason.

Stuart Green’s summary chart shows activity based on the rate of change in the magnetic field, while the other charts all show the field intensity over time, accounting for the apparent weaker activity at the end of November that appears to be stronger in the summary chart.

Magnetic observations received from Roger Blackwell, Colin Clements, Stuart Green, Nick Quinn and John Cook.

## SOLAR EMISSIONS

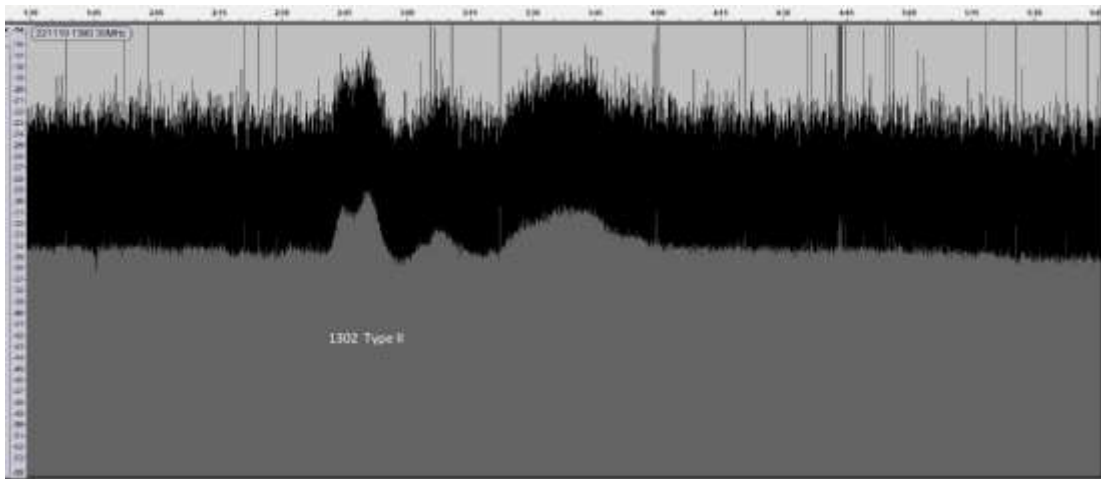
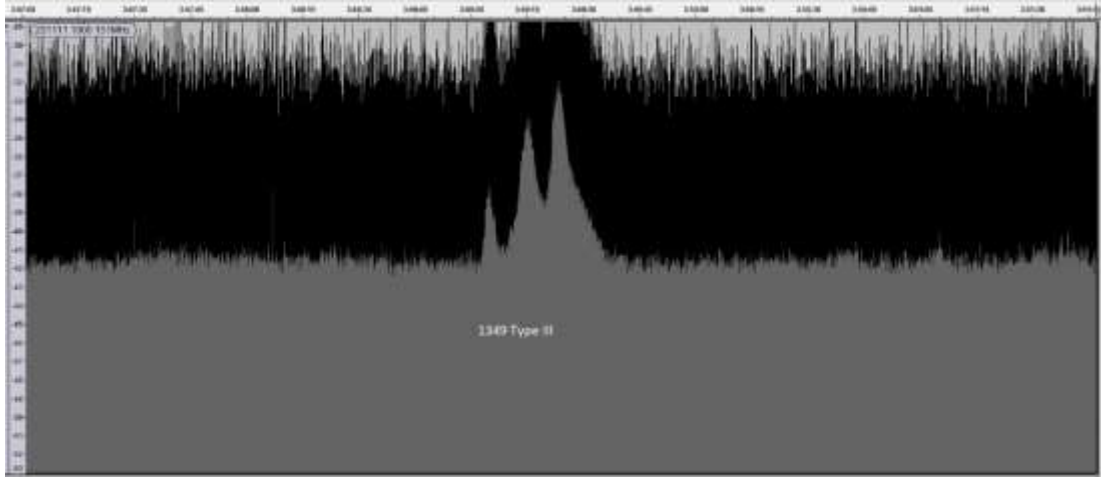

Colin Briden made two solar emission recordings, the first a type III burst at 13:49UT on the 11<sup>th</sup> at 151MHz. Shown in the top image, this lasts for just 30 seconds, with an amplitude of about 10dB. It does not match any of our recorded flares, but does match the timing of a C1.0 flare listed in the SWPC satellite data. The second recording shows a type II burst at 13:02UT on the 19<sup>th</sup> at 30MHz. This lasts for about one minute, with a 5dB amplitude. This one matches the M1.6 flare shown in our SID recordings.

Colin has noticed that the 28-30MHz band is becoming more noisy with interference as the increased solar activity allows better HF propagation. There is also the problem of the sun being much lower in the sky at this time of year. These recordings are currently made using a simple dipole aerial that can easily be trimmed to suit different frequencies. Colin Clements is unable to make VHF recordings while the sun remains below his aerial's horizon.

## MUON OBSERVATIONS

Mark Prescott has continued his muon recordings, shown in the charts on the next page. There does not appear to be any stand-out events this time, but it does seem that the general muon count is lower during periods of faster solar wind.

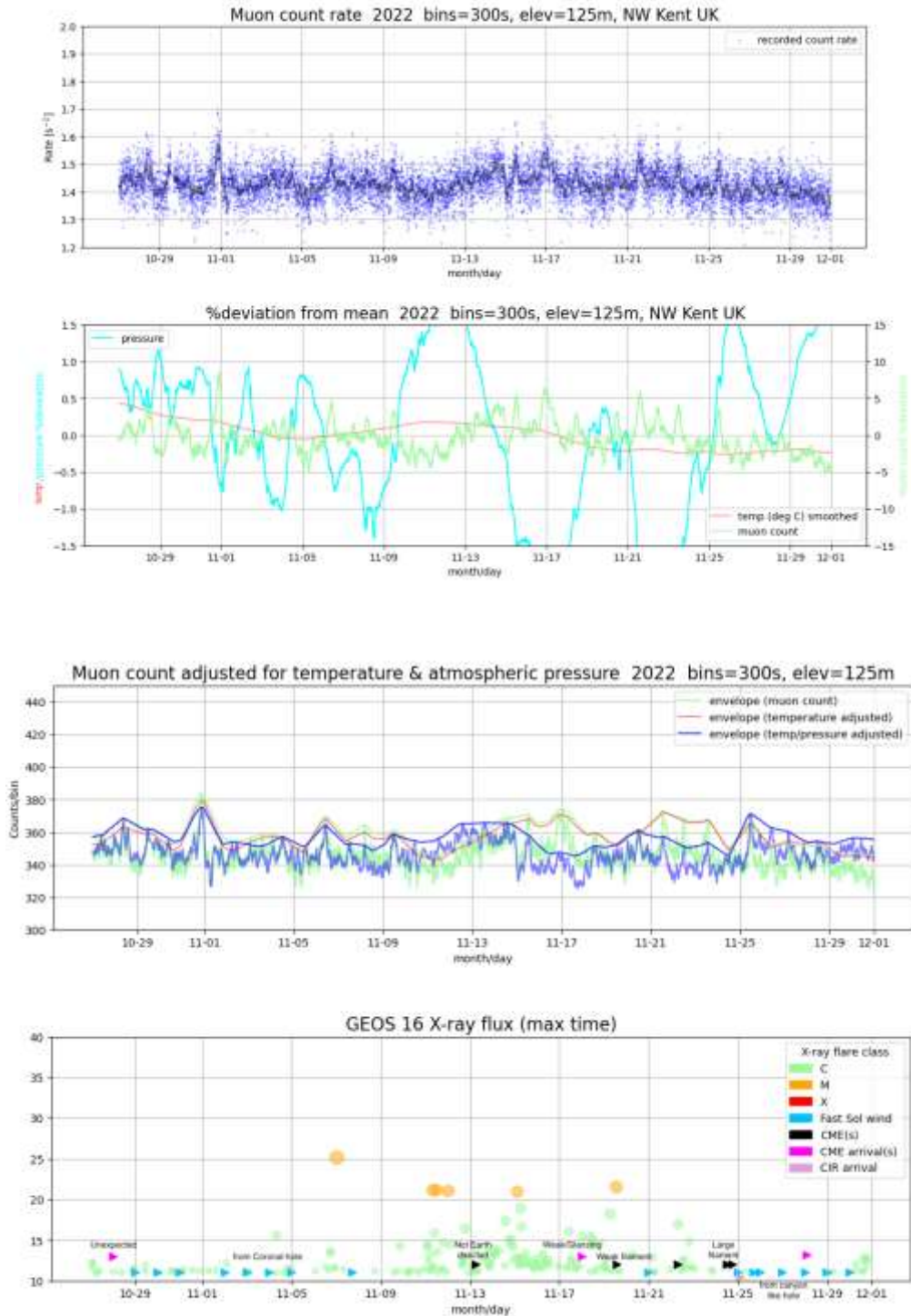



Mark has also been analysing his data during the GRB recorded on October 9<sup>th</sup>. The chart on the next page shows a wavelet transform, indicating a slightly higher muon count on the 9<sup>th</sup> and 10<sup>th</sup>. The GRB timing is marked with a vertical line near the centre of the chart. The vertical axis represents the wavelet period in recording bins, with colour indicating the intensity. There is also a higher count on the 10<sup>th</sup>. There is a general trend of increased intensity during daylight hours compared with night. This represents just a single observation, and so the link to the GRB is probably weak. It is however a useful recording that can be used to compare with other active and quiet periods over the next year or so as we learn to interpret the data.

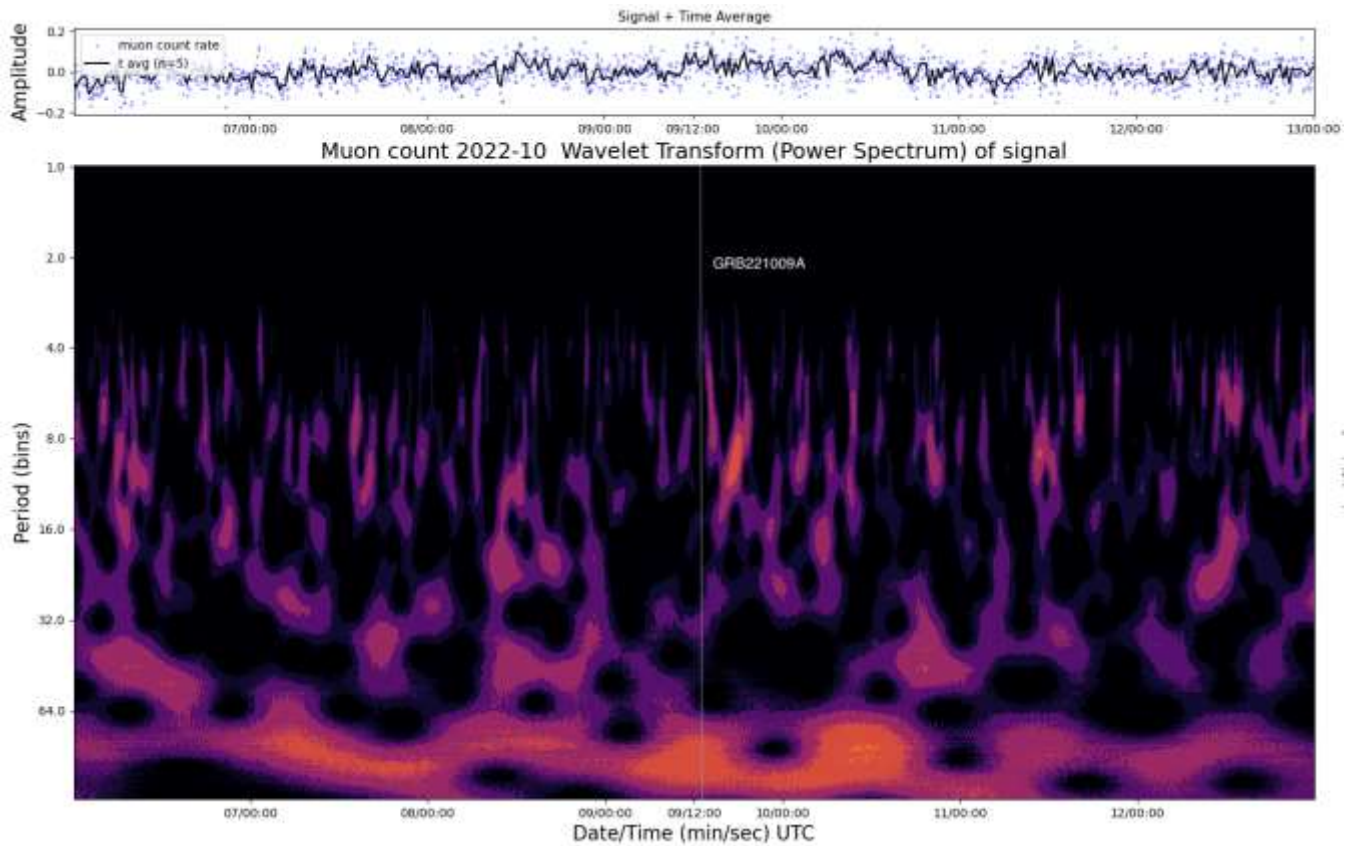

There will be a solar section Zoom webinar on February 18<sup>th</sup>, including a radio astronomy contribution from Paul Hearn. Full details can be found on the BAA website.

VLF SID OBSERVATIONS

December was a very busy month for solar flares, with plenty of stronger M-class events. Roberto Battaiola describes it as a “fireworks December”, a very good description. His recording from the 14<sup>th</sup> gives an example of the mid-month activity:

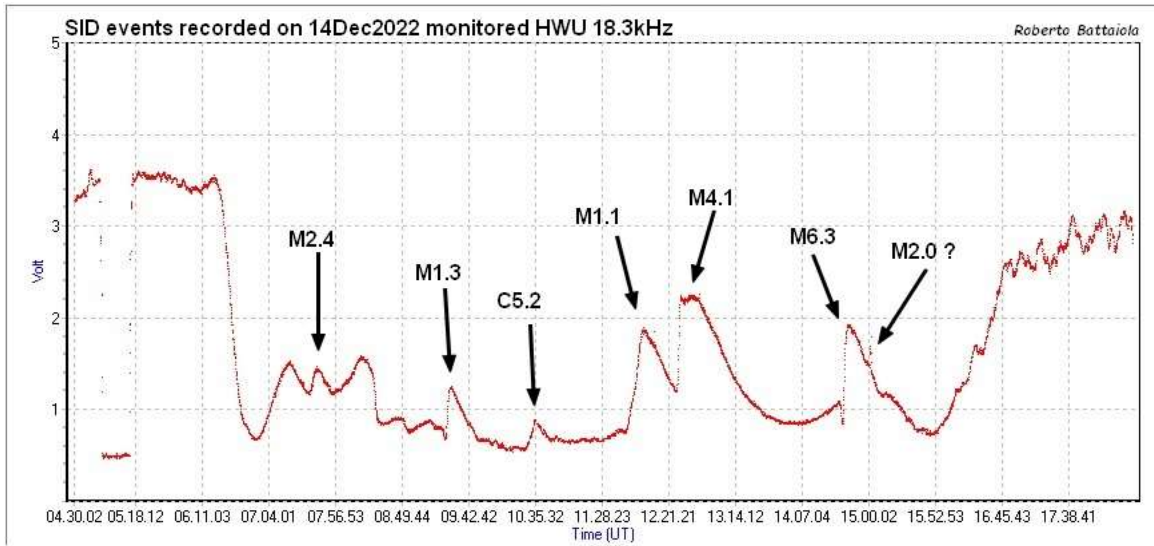

It also shows how many of the flares overlapped and merged, making analysis quite difficult. The spike at 15:00 identified as M2.0? is probably from the M3.2 flare. The very early M2.4 flare is also visible, lost in the morning sunrise to observers here in the UK.

All of the M-class flares in mid-December were produced by active region AR13165, a medium sized Southern hemisphere sunspot group that was approaching the Western limb of the sun. There are no X-class flares shown in the satellite data.

Activity continued on the 15<sup>th</sup>, shown in the recording by Mark Prescott. Background levels were also quite high, so even the M-class flares did not produce clear SIDs for all observers.

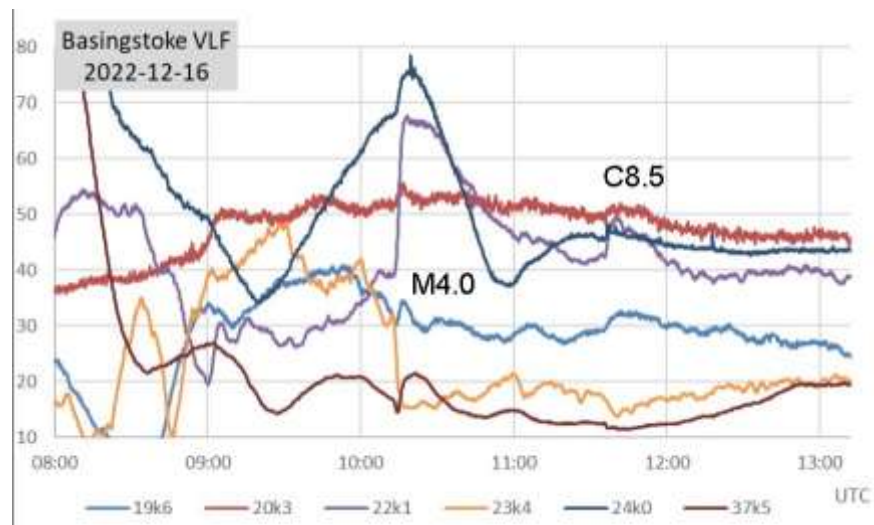
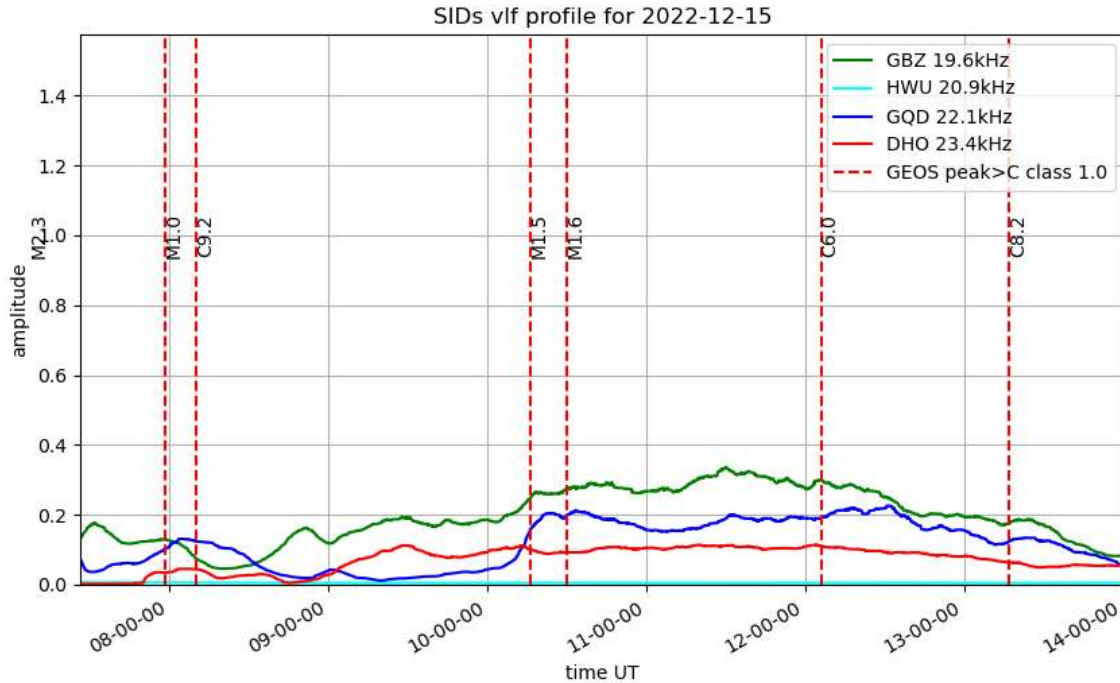

Paul Hyde's recording from the 16<sup>th</sup> shows the M4 flare peaking at 10:19UT. There is a clear SID at 22.1kHz, with a much less distinct effect at 19.6kHz. There is a small 'spike & wave' SID at 37.5kHz, while it sits on sunrise for the 24kHz trans-Atlantic signal.

With the sun at its lowest altitude in the sky during December, the Ionosphere D-region is often very unstable. My own recordings have been very noisy, saturating the receiver on several days. Paul Hyde's recording from the less active 2<sup>nd</sup> shows a well camouflaged C8.1 flare, nearly lost shortly after the local sunrise, followed by generally unstable conditions.

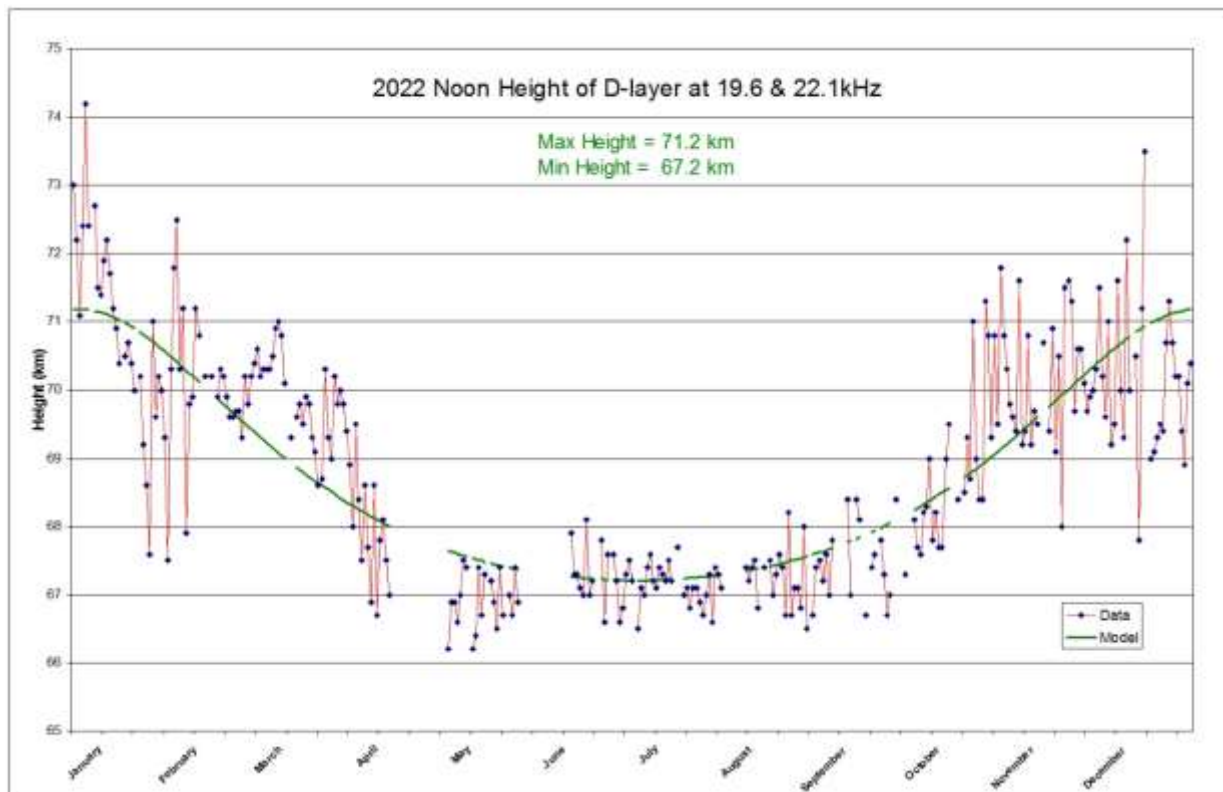
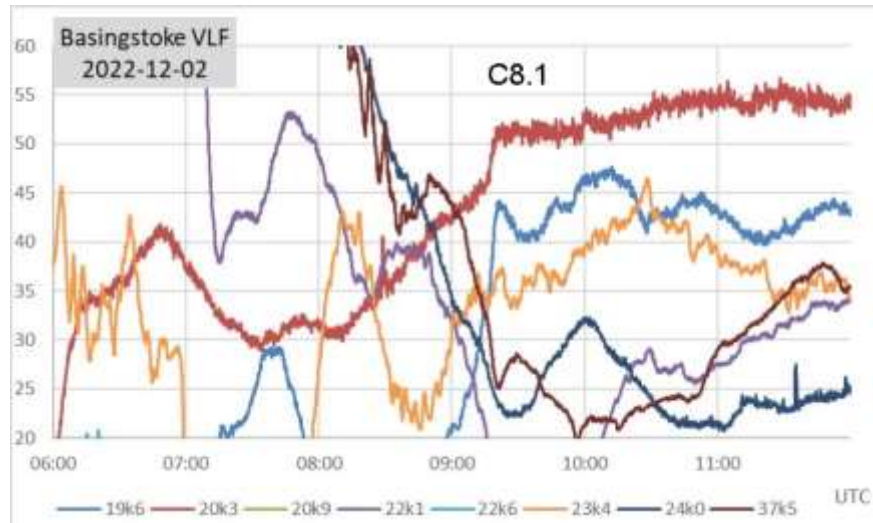

Mark Edwards has produced his analysis of D-region heights through the year, data points shown in red with the model output in green. The general winter instability just described results in the wider spread of data points from November to February. The chart on the next page shows how these heights have varied since 2010, compared with our SID counts over that period. The minimum height has been fairly stable around 67km, while the maximum height seems to fall as solar activity increases, rising during the solar minimum period.

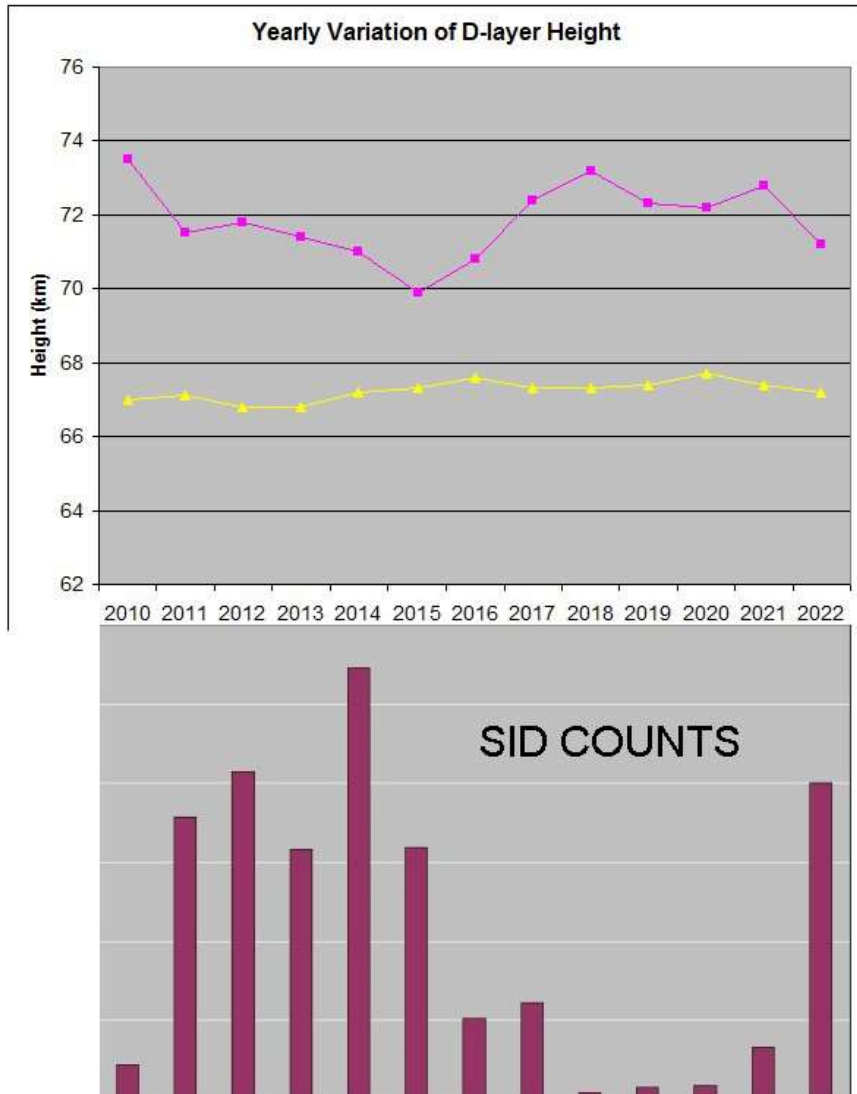

The SID counts are the number of individual peaks recorded, rather than the number of classified flares. This probably better represents solar activity, given that many of the stronger flares do have multiple peaks. The chart shows that the current solar cycle is making a very strong start, with 800 SIDs recorded in 2022.

## MAGNETIC OBSERVATIONS

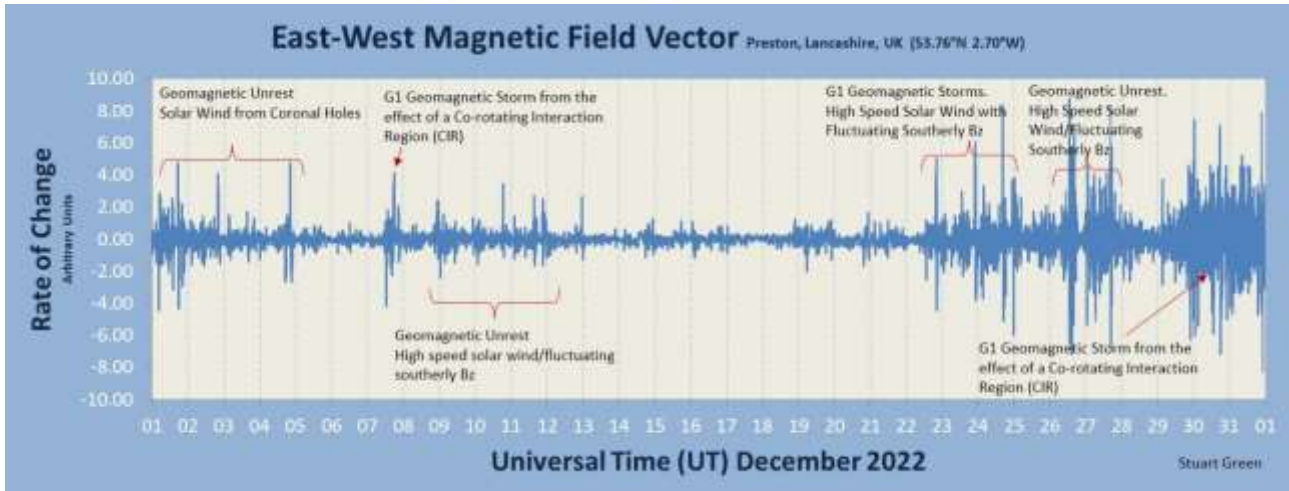

Stuart Green's monthly summary of magnetic activity shows a fairly gentle start to December, becoming much more active during the last week of the month. Once again most of the activity has been from faster solar winds, with little effect from CMEs. Some of the M-class flares did produce a CME, but they were not directed towards Earth, and so had little impact. The fast solar winds at the end of November continued into early December with some mild magnetic disturbances. Nick Quinn's recording from the 1<sup>st</sup> shows the disturbance:



This continued into the 4<sup>th</sup>, with a larger equatorial coronal hole creating a more turbulent solar wind and a more active magnetic disturbance from the afternoon into the evening. There was less disturbance on the 5<sup>th</sup>

and 6<sup>th</sup>, with another mild disturbance on the 7<sup>th</sup>. Conditions then remained fairly quiet until the coronal holes again began to be geo-effective from the 22<sup>nd</sup>.



Roger Blackwell’s recordings over the 22<sup>nd</sup> to 24<sup>th</sup> show some moderate disturbance from the solar wind. The 25<sup>th</sup> remained fairly quiet, activity increasing again in the afternoon of the 26<sup>th</sup>. The disturbance continued on the 27<sup>th</sup>, shown in the recording by Nick Quinn:

Steying Magnetometer (50.8 North, 0.3 West)

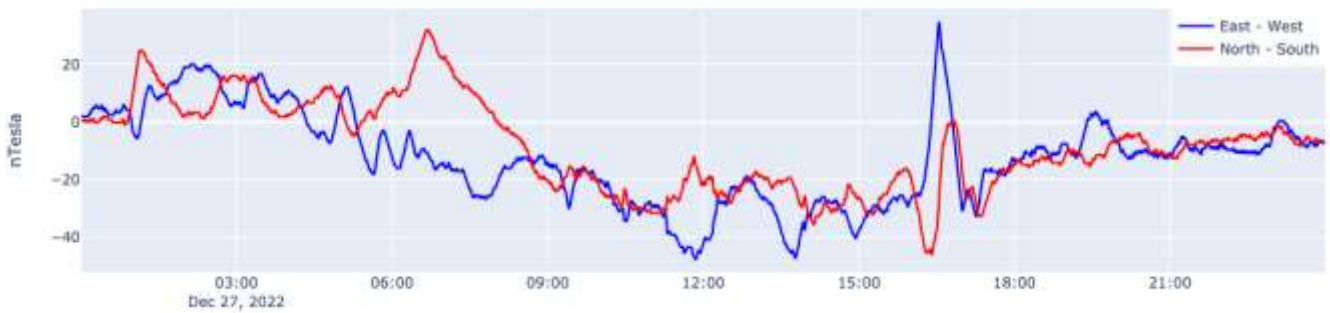

The 28<sup>th</sup> and 29<sup>th</sup> were less disturbed, activity increasing again on the 30<sup>th</sup>.

Magnetic observations received from Roger Blackwell, Stuart Green, Nick Quinn and John Cook.

## METEORS

Observations of the Geminid meteor shower were made by Colin Clements and Chris Bailey, showing some good activity.

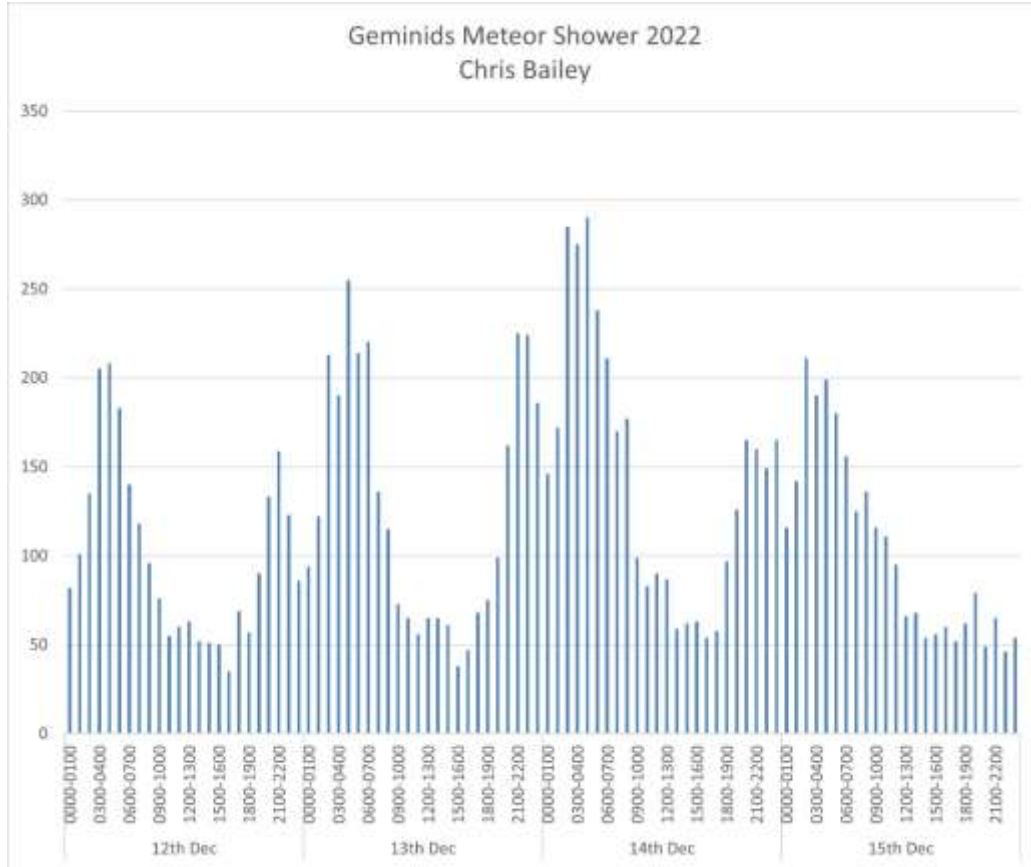

This chart from Chris Bailey shows activity peaks around 03 to 07 UT over the 12<sup>th</sup> to 15<sup>th</sup>, strongest on the 14<sup>th</sup>. This matches well with the predictions in the 2022 BAA handbook. Chris has also compared Geminid counts over the last four years, shown on the next page. 2019 seems to have been slightly weaker, with similar numbers in 2021 and 2022. Counts were made over 30 second bands, and carefully examined to remove Starlink interference. 2020 is missing due to equipment problems.



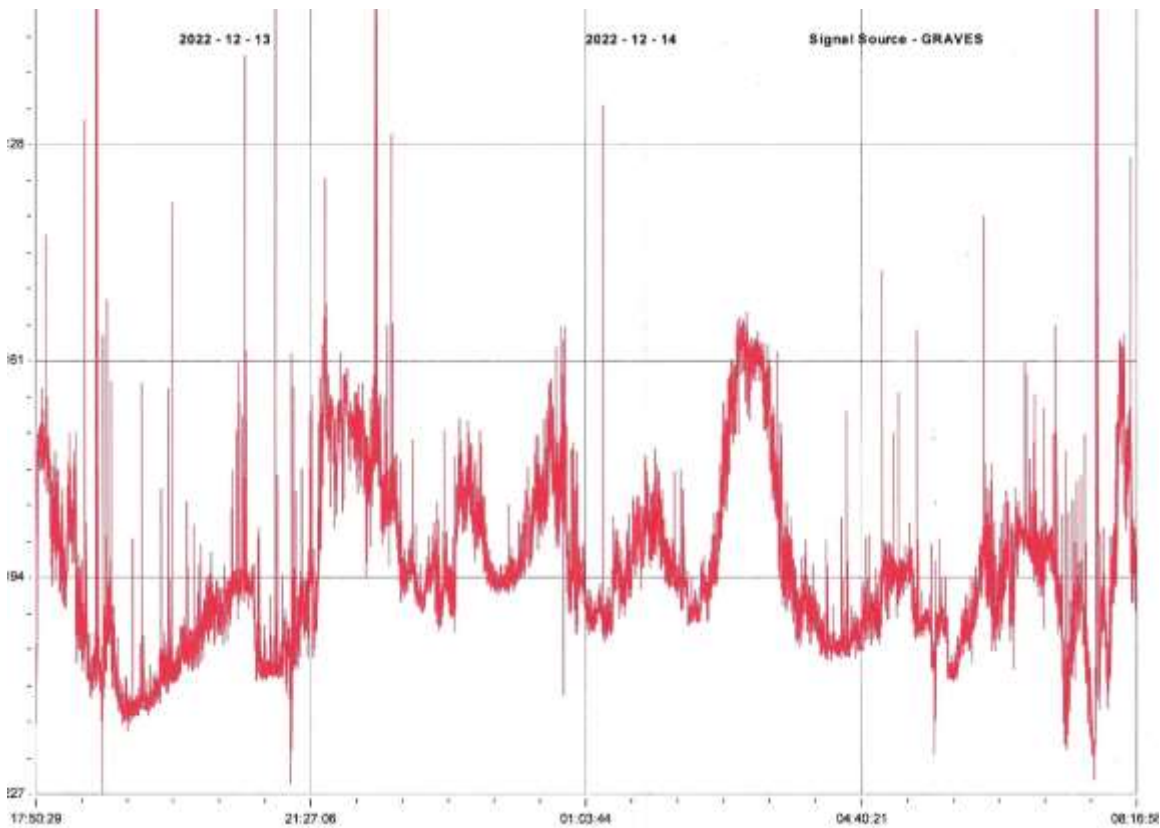
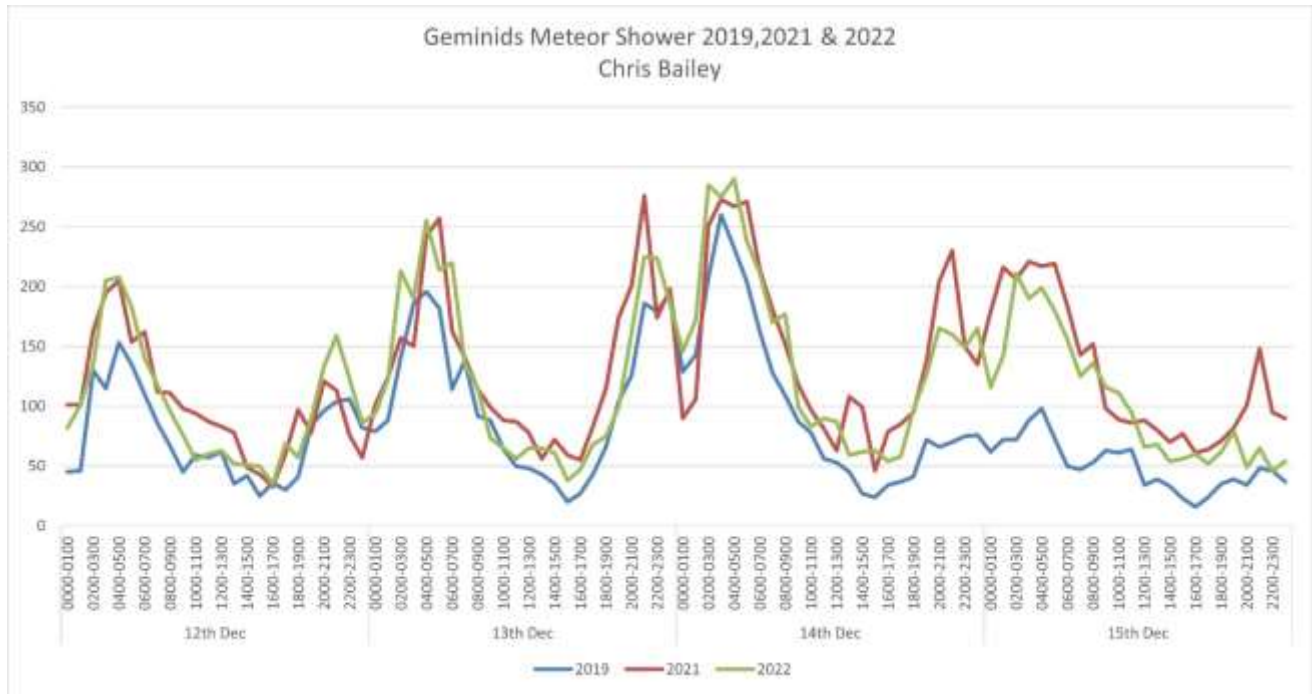

Colin Clements' chart shows the evening of the 13<sup>th</sup> into the morning of the 14<sup>th</sup>, but does include 'noise' spikes unrelated to meteors. The early morning peak is also clear, with smaller peaks throughout the period. Similar small peaks were also recorded on the 15<sup>th</sup>.

## MUONS

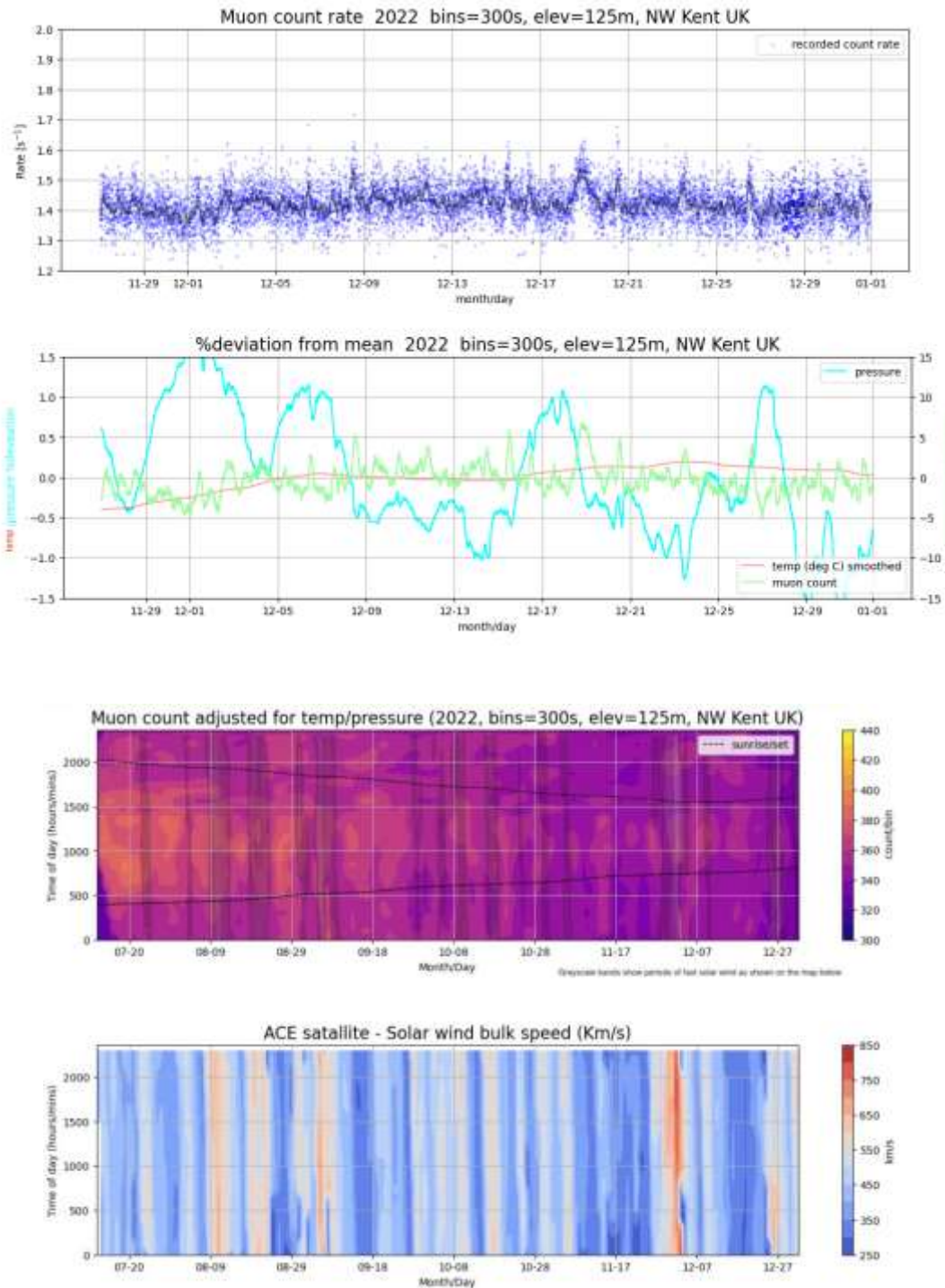

The top chart shows the muon counts for December, recorded by Mark Prescott, together with pressure and temperature variations. The second chart shows adjusted counts from July to the end of the year in the upper panel. The black lines show sunset and sunrise times, with the brighter yellow regions indicating higher muon

counts. These clearly follow the day length and season. The higher solar altitude gives a warmer atmosphere in summer, causing it to expand slightly resulting in a lower density. This allows more cosmic particles into the lower regions, converting into muons as they react with the atmospheric gases. This does give some confidence in the detection equipment and method.

### SOLAR EMISSIONS

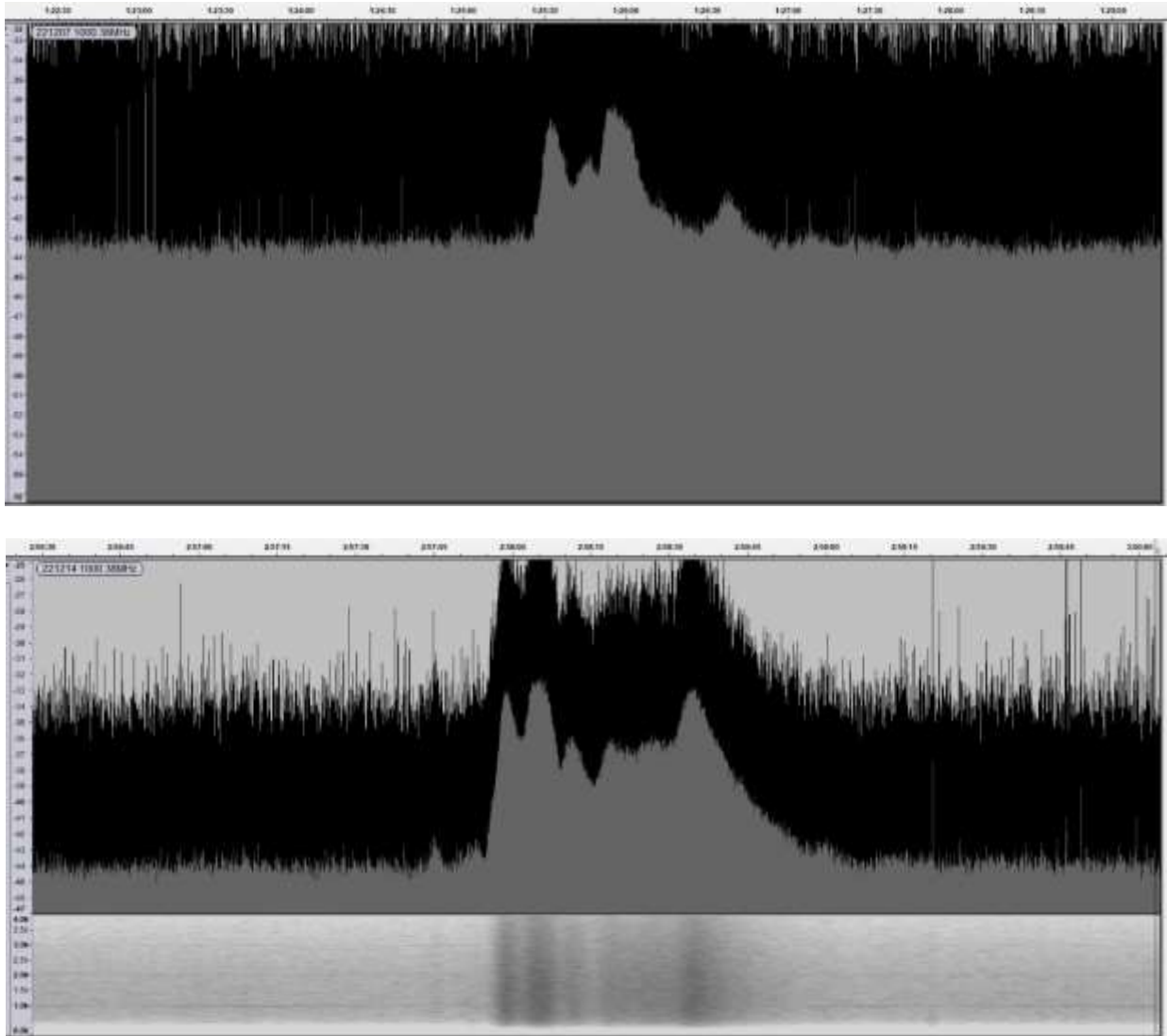

Colin Briden has recorded two type III radio bursts. The first was at 11:25UT on the 7<sup>th</sup>, matching a small C1.2 flare. The burst lasts about 1 minute, and rises about 6dB above the background. The second was at 12:58UT on the 14<sup>th</sup>, matching the series of M-flares recorded as SIDs. This one rises about 11dB above the background level and also lasts about a minute. Colin has added a spectrogram below the main amplitude display. He also notes that interference has become more of a problem while the sun is lower in the winter sky. Looking forward to the spring, I hope that this problem improves.

Our series of zoom meetings organised by Paul Hearn continues. Full details of these meetings can be found through the BAA web site.

# BARTELS CHART

YEAR	KEY	STATUS														S, C, M, X = FLARE MAGNITUDE	Symbol relative shift (longitude)	
		0	1	2	3	4	5	6	7	8	9	10	11	12	13			14
2543	F	0	1	2	3	4	5	6	7	8	9	10	11	12	13	14	2001 February	2001
2544	F	0	1	2	3	4	5	6	7	8	9	10	11	12	13	14	2001 March	2001
2545	F	0	1	2	3	4	5	6	7	8	9	10	11	12	13	14	2001 April	2001
2546	F	0	1	2	3	4	5	6	7	8	9	10	11	12	13	14	2001 May	2001
2547	F	0	1	2	3	4	5	6	7	8	9	10	11	12	13	14	2001 June	2001
2548	F	0	1	2	3	4	5	6	7	8	9	10	11	12	13	14	2001 July	2001
2549	F	0	1	2	3	4	5	6	7	8	9	10	11	12	13	14	2001 August	2001
2550	F	0	1	2	3	4	5	6	7	8	9	10	11	12	13	14	2001 September	2001
2551	F	0	1	2	3	4	5	6	7	8	9	10	11	12	13	14	2001 October	2001
2552	F	0	1	2	3	4	5	6	7	8	9	10	11	12	13	14	2001 November	2001
2553	F	0	1	2	3	4	5	6	7	8	9	10	11	12	13	14	2001 December	2001
2554	F	0	1	2	3	4	5	6	7	8	9	10	11	12	13	14	2002 January	2002
2555	F	0	1	2	3	4	5	6	7	8	9	10	11	12	13	14	2002 February	2002
2556	F	0	1	2	3	4	5	6	7	8	9	10	11	12	13	14	2002 March	2002
2557	F	0	1	2	3	4	5	6	7	8	9	10	11	12	13	14	2002 April	2002
2558	F	0	1	2	3	4	5	6	7	8	9	10	11	12	13	14	2002 May	2002
2559	F	0	1	2	3	4	5	6	7	8	9	10	11	12	13	14	2002 June	2002
2560	F	0	1	2	3	4	5	6	7	8	9	10	11	12	13	14	2002 July	2002
2561	F	0	1	2	3	4	5	6	7	8	9	10	11	12	13	14	2002 August	2002
2562	F	0	1	2	3	4	5	6	7	8	9	10	11	12	13	14	2002 September	2002
2563	F	0	1	2	3	4	5	6	7	8	9	10	11	12	13	14	2002 October	2002
2564	F	0	1	2	3	4	5	6	7	8	9	10	11	12	13	14	2002 November	2002
2565	F	0	1	2	3	4	5	6	7	8	9	10	11	12	13	14	2002 December	2002
2566	F	0	1	2	3	4	5	6	7	8	9	10	11	12	13	14	2003 January	2003
2567	F	0	1	2	3	4	5	6	7	8	9	10	11	12	13	14	2003 February	2003
2568	F	0	1	2	3	4	5	6	7	8	9	10	11	12	13	14	2003 March	2003
2569	F	0	1	2	3	4	5	6	7	8	9	10	11	12	13	14	2003 April	2003
2570	F	0	1	2	3	4	5	6	7	8	9	10	11	12	13	14	2003 May	2003
2571	F	0	1	2	3	4	5	6	7	8	9	10	11	12	13	14	2003 June	2003
2572	F	0	1	2	3	4	5	6	7	8	9	10	11	12	13	14	2003 July	2003
2573	F	0	1	2	3	4	5	6	7	8	9	10	11	12	13	14	2003 August	2003
2574	F	0	1	2	3	4	5	6	7	8	9	10	11	12	13	14	2003 September	2003
2575	F	0	1	2	3	4	5	6	7	8	9	10	11	12	13	14	2003 October	2003
2576	F	0	1	2	3	4	5	6	7	8	9	10	11	12	13	14	2003 November	2003
2577	F	0	1	2	3	4	5	6	7	8	9	10	11	12	13	14	2003 December	2003
2578	F	0	1	2	3	4	5	6	7	8	9	10	11	12	13	14	2004 January	2004
2579	F	0	1	2	3	4	5	6	7	8	9	10	11	12	13	14	2004 February	2004
2580	F	0	1	2	3	4	5	6	7	8	9	10	11	12	13	14	2004 March	2004
2581	F	0	1	2	3	4	5	6	7	8	9	10	11	12	13	14	2004 April	2004
2582	F	0	1	2	3	4	5	6	7	8	9	10	11	12	13	14	2004 May	2004
2583	F	0	1	2	3	4	5	6	7	8	9	10	11	12	13	14	2004 June	2004

### VLF flare activity 2005/22

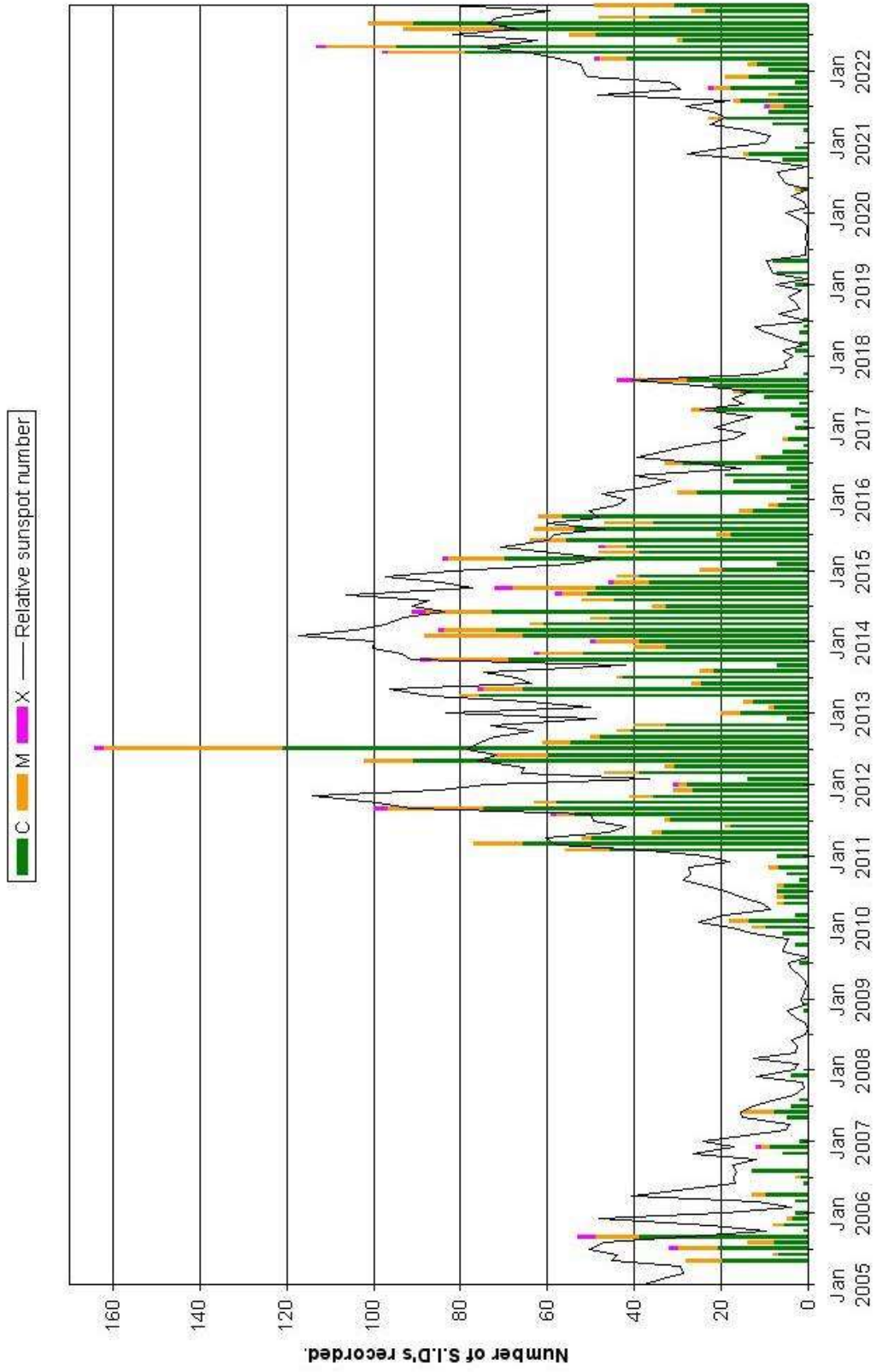



**British Astronomical Association**

Supporting amateur astronomers since 1890

**Radio Astronomy Section**

## BAA RA Section Winter programme 2023

Date	Presenter	Topic
<b>Mar. 3rd</b> Friday 19:30 GMT (19:30 UTC)	<b>Dr. Chuck Higgins</b> Middle Tennessee State University Physics and Astronomy Dept.	<b>Citizen Science and Radio Jove</b> The Science and instrumentation for a Radio exploration of Jupiter
<b>Mar. 31st</b> Friday 19:30 GMT (18:30 UTC)	<b>Dr John Veitch</b> Senior Lecturer Institute for Gravitational Research School of Physics & Astronomy, University of Glasgow	<b>What gravitational waves can tell us about the universe</b>

If you have any suggestions for the winter 2023 term do let me know.

Our meetings are open to all. Once you are registered on the RA Section email list the Zoom link will be sent out to you before the meeting. If you are not on the email list, please request registration from Paul Hearn ( [paul@hearn.org.uk](mailto:paul@hearn.org.uk) ).

# VINTAGE SARA

CHARLES OSBORNE, SARA HISTORIAN

## *Fading Voices and Data*

While doing last month's column on SARA experiences at the Woodbury Research Facility in the 1993 ~ 1997 timeframe it forced me to dive into old files, diskette data, videotapes, and pictures. Thanks for all the good comments about that column from the readers.

I found that just because a diskette's File Allocation Table (FAT) will read, doesn't mean the files themselves are still readable. And any faded data causes a Cyclic Redundancy Check which causes the files to no longer be copiable. It was also an interesting lesson in quality which might have been of value thirty years ago when buying the magnetic media. The verdict, cheap media is just that. I found that the no name cheapie media no longer reads, while the name brands still were good. So if you have old diskettes, VHS tapes, or even film, get it digitized and transferred into a newer form before the ravages of time, temperature, and humidity make it fade into obscurity.

Also, if you are trying to read old magnetic media, get a head cleaning kit. It uses something like alcohol in a slightly abrasive cloth pad to sweep magnetic dust build up off the heads. Use it frequently. Old tapes and diskettes shed that magnetic material much more as well. It's like trying to play an old record that's been open to dust. Don't expect good results without cleaning. And if you read dirt into the drive, it only gets worse. So clean often.

I've now done a lot of that archiving to new digital forms and will be uploading YouTubes as I am able to edit them down and label who is who in the video.

It's interesting to be listening to a video and realize its being taken and narrated by someone I haven't seen in years. One's own memory is certainly subject to the ravages of time as well. In many cases important tapes are reduced to a few words on a label to figure out the who, when, and where of it all. I wished I had hit the time/date on screen labels a lot more often or even verbally read into the tape what the date and place was. I did find that a number of people were helping video using my camera while I was busy building up a receiver or feed system. They were pretending to be the newscaster doing the interview and I'm now thankful for that. Mental note, use a tripod more. Some of these are real roller coaster rides.

I will try to label a few of the videos with who is talking. In many cases I still recognize the voices. Many of them are no longer with us. Past SARA Presidents Mike Gingell and Chuck Forster for example are on these tapes. Chuck in fact did a whole video tape on what radio astronomy is all about while showing us his own dishes and system. The video quality of that one did not survive well, so understand it's all we have, and take it for what it is. If you have a better copy, please let us know. But it is good to see Chuck at his best.

Audio likewise in some of these tapes is really bad. If ambient noise levels are high try to find a quieter spot to add in voice information. And if you are behind the camera or cellphone know that your voice

may not come across well. Several of the tapes I have to work with have to be turned up quite loud to make out the details. In ham radio I'm a weak signal troposcatter DXer. So, I'm a lot more used to digging a voice out of the noise. I know others may want studio quality audio. This isn't CSI or the FBI's crime lab. I can't unscramble the eggs with DSP magic.

**Some of the upcoming tapes I'm working with include:**

- Jeff Lichtman giving a History of SARA's First 10 Years at Green Bank Conf 1991
- Grote Reber's 1996 SARA Conference lecture "The Big Bang is Bunk"
- Dr Paul Goldsmith lecture on Arecibo and the installation of the Gregorian Dome
- Dr Paul Horowitz conference lecture
- SARA first tour of PARI in fall of 1998 and early volunteering at the site
- Tom Clark K3IO (SK) narrating a tour of the Kitt Peak VLBA site
- 12m Millimeter Wave Radio Telescope tour on Kitt Peak (shut down now I believe)
- Also have the optical facilities on Kitt Peak as well if interested let me know. McMath Solar Observatory (I believe is closed now).
- Also, I have a full video tour of the Titan Missile Museum south of Kitt Peak for those into Cold War history. It is a Titan similar to what put the Gemini astronauts in space.



Jim Carroll N4CAE showing Grote Reber his SARA 408 MHz receiver project at SARA Conf '96.



## Featured Articles

### An HI Telescope Using an Odroid XU4 Single Board Computer By Tom Hagen

#### Introduction

As the happy recipient of an Odroid XU4 single board computer (SBC) door prize at the 2022 SARA Annual Conference, I decided to try using it to do some kind of radio astronomy. Since I've been doing hydrogen line observing recently, I thought it'd be fun to set up the XU4 for 21 cm HI work. This paper describes what I did to get the Odroid running with GNU Radio. The main resources I used include GNU Radio sketches, tutorials, and horn designs provided by the Digital Signal Processing in Radio Astronomy (DSPIRA) project. DSPIRA is a part of the West Virginia University Radio Astronomy Instrumentation Laboratory (WVU RAIL) group. I highly recommend DSPIRA as the best resource for amateurs learning to work HI. Many thanks to Jay Wilson for his donation of the Odroid as a door prize. Jay mentioned that he received this Odroid from a student group at a previous SARA Annual Conference that they did indeed use it for HI observations with a conical horn.

The Odroid was successfully used to make HI observations using GNU Radio (GR) and GR sketches provided by DSPIRA. Detailed software installation instructions are found in the Appendix.

#### What is the Odroid SBC?

The Odroid SBC is one of a burgeoning number of SBC's available now, the most well-known of which is the Raspberry Pi. These SBC's typically use mobile phone processors that are widely available due to the massive quantities manufactured. The XU4 was released in 2015 by the South Korean company HardKernel [1] and is similar in performance to a Raspberry Pi 4.

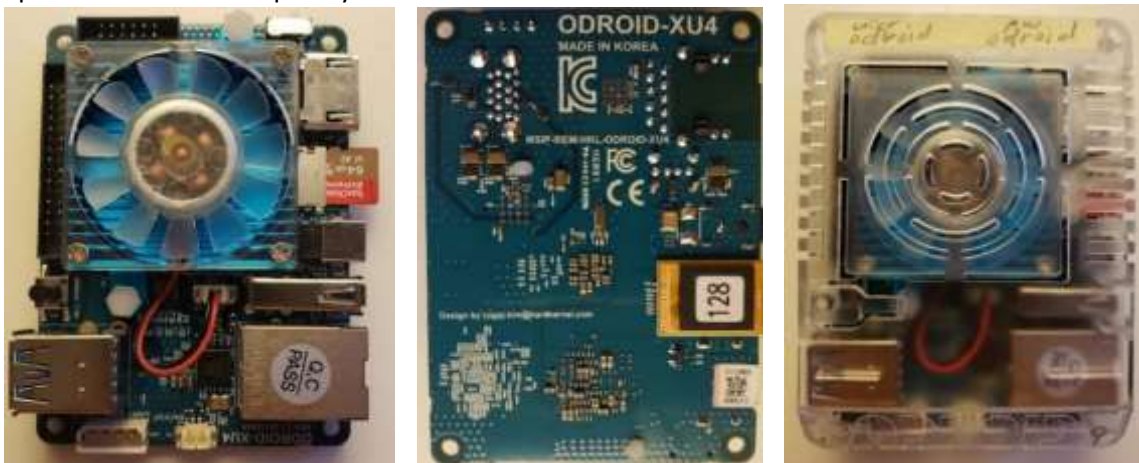

Odroid XU4 Single Board Computer: Top, Bottom, Mounted in Case

The XU4 uses the Samsung Exynos5422 Cortex™-A15 2GHz and Cortex™-A7 Octa core CPUs, has 2 GB of RAM, and features 2 USB 3.0 ports, 1 USB 2.0 port, full-sized HDMI connector, and Gigabit Ethernet port. The XU4 is not equipped with WiFi or Bluetooth capability. Permanent memory storage is provided by either an SD card or an eMMC card. A switch on the circuit board selects between the cards. I'm using the 64 GB SD card visible in the top view above and a 128 GB eMMC card visible in the bottom view above. At present the Linux image is on the SD card and an Android image is on the eMMC card.

Android is the native operating system for the Odroid, but there is an Ubuntu **20.04** MATE Desktop distribution available from HardKernel [1] and this is the Linux distro I used for this project. It's important to install the 20.04 version of Ubuntu because the GNU Radio sketches from DSPIRA are written in GNU Radio, version 3.8, which uses Python 3.8. I had trouble installing the DSPIRA tools on Ubuntu 22.04. The problems with 22.04 may be related to the fact that 22.04 comes with Python 3.10 as the default version. DSPIRA is working at this time to update the sketches for GR 3.10. In the future I might have a whack at running GNU Radio on Android. There is a group out there working on this, but the project looks pretty advanced for my skill level so I'm sticking to Linux for now. You can run the DSPIRA sketches on other SBC's such as the Raspberry Pi; there are instructions on the DSPRA site on how to do this.

### What is GNU Radio?

From the GNU Radio site [2]: "GNU Radio is a free & open-source software development toolkit that provides signal processing blocks to implement software radios. It can be used with readily-available low-cost external RF hardware to create software-defined radios, or without hardware in a simulation-like environment. It is widely used in research, industry, academia, government, and hobbyist environments to support both wireless communications research and real-world radio systems."

From the above site: "In brief, a software radio is a radio system which performs the required signal processing in software instead of using dedicated integrated circuits in hardware. The benefit is that since software can be easily replaced in the radio system, the same hardware can be used to create many kinds of radios for many different communications standards; thus, one software radio can be used for a variety of applications!"

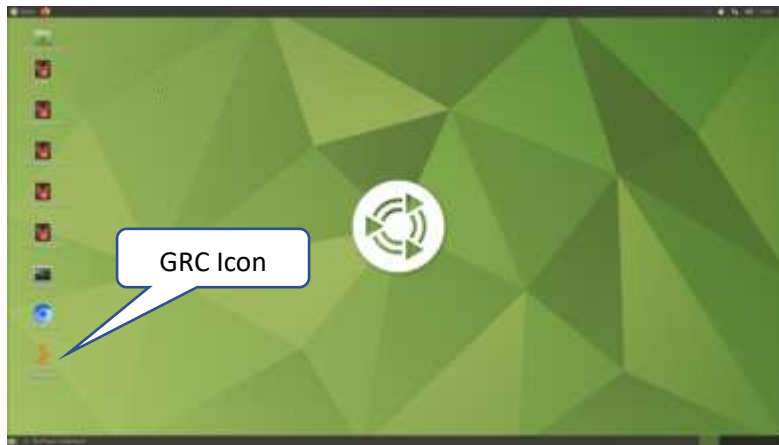

**Odroid Ubuntu MATE Desktop**

There is a graphical interface called GNU Radio Companion (GRC) that lets GR users create block diagrams. When you start the XU4 you get the desktop view above. Double click the GRC icon and GRC starts up and gives you a new blank screen as seen below.

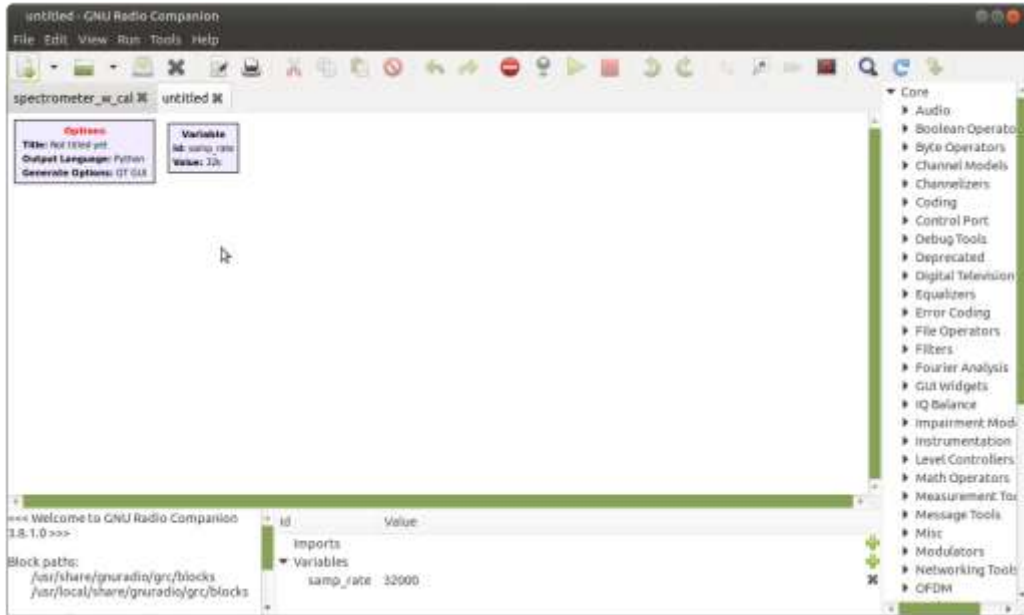

**GNU Radio Companion: New Window**

A sketch from the DSPIRA group is seen below. This is the sketch I used to observe HI in the galactic plane. The only change to this existing “spectrometer\_w\_cal” sketch was to add my RTL-SDR SDR dongle and change the variable to supply power from the dongle to the Nooelec filtered preamp that I use.

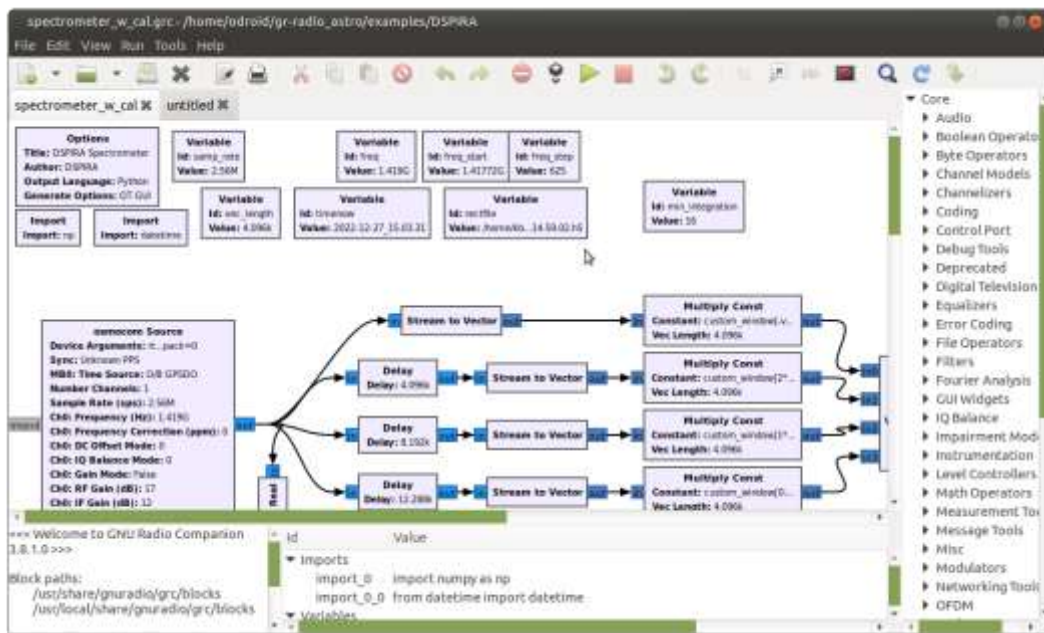

**GNU Radio Companion Sketch from DSPIRA**

The default setup is configured for an Airspy R2 SDR and since I’m using an RTL-SDR dongle (RTL2832U), I had to change the “Device Arguments” settings in the osmocom Source to “rtl=0” from “airspy=0”. The “bias=1” setting supplies 5VDC to the external preamp from the RTL-SDR, and the “pack=0” setting is an option for the Airspy source referring to packed/unpacked USB transmission and appears to have no effect on RTL-SDR dongle operation. Access these settings by double clicking on the osmocom Source block as seen below.

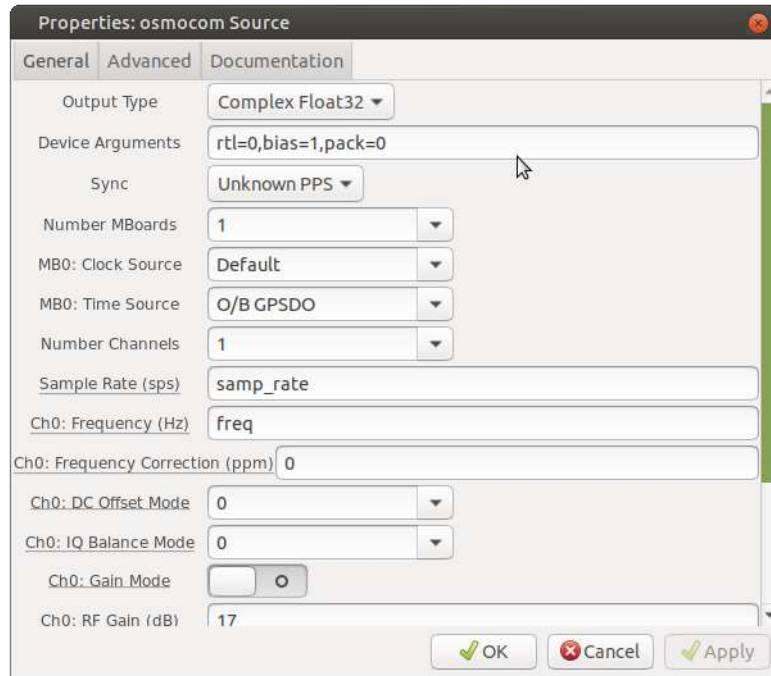

**Setup for the RTL2832U Dongle**

You'll also need to set the sample rate variable in the upper left corner to 2-3 MHz or so. To set the rate to 2.56 MS/s for example, enter the "Value" as 2.56e6.

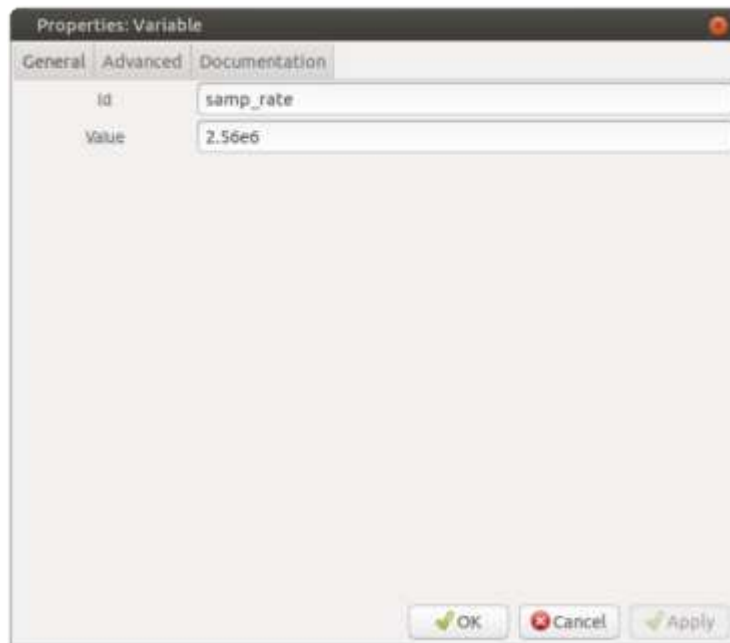

**Sample Rate Setup for the RTL2832U Dongle (2.56 MS/s)**

To start the sketch, press on the green triangle on the top menu bar. Pressing the red square stops the sketch. The running sketch appears in the following figure. It's important to follow the hot/cold procedure for calibrating the telescope too, because otherwise you will not get a clean view of the HI spectrum.

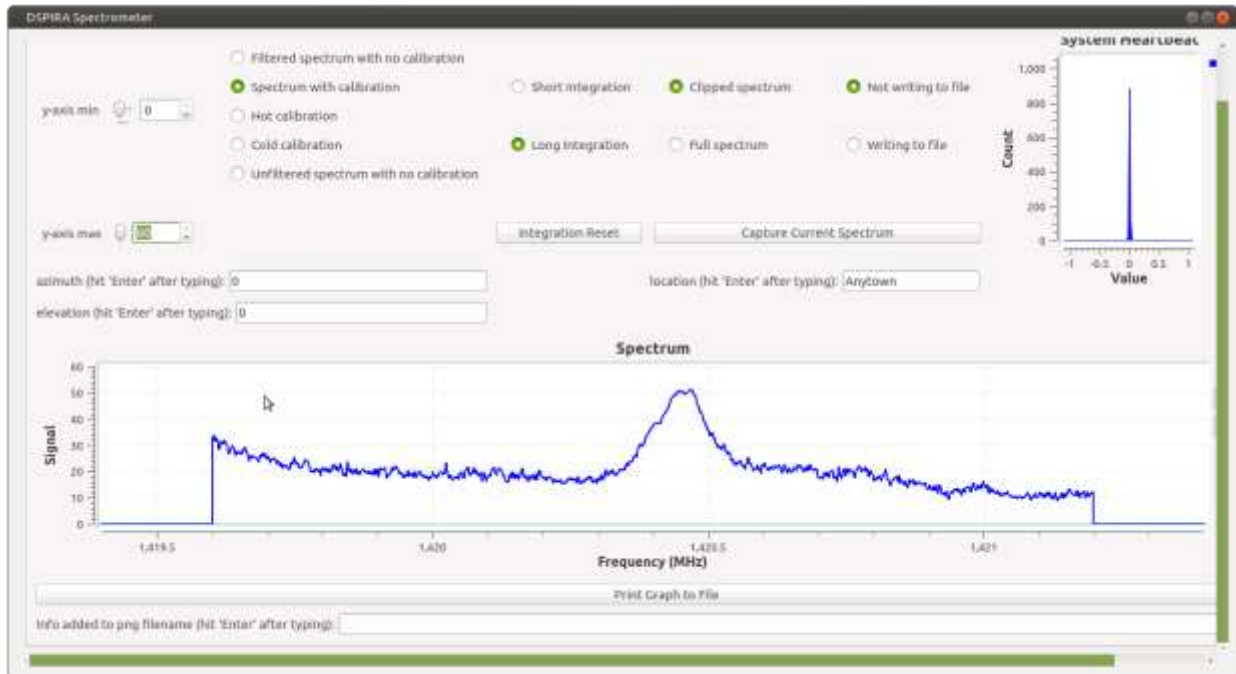

DSPIRA “spectrometer\_w\_cal.grc” Sketch in Operation

### What is DSPIRA?

The website [3] of The Digital Signal Processing In Radio Astronomy group states: “(DSPIRA) is an NSF Research Experiences for Teachers (RET) in Engineering and Computer Science Site at the West Virginia University Lane Department of Computer Science and Engineering”.



DSPIRA Horn with Base

“(DSPIRA) was designed to provide teachers the training and materials in the field of Radio Astronomy. This acts as a stepping stone for an eclectic journey through science and engineering with the given context in Astronomy. The culmination of this program are lessons and exercises designed by the participating cohort of teachers themselves. These lessons involve all aspects of Radio astronomy from building a radio telescope to its operation.”

DSPIRA provides six-week summer sessions for high school science teachers desiring to learn about radio astronomy, digital signal processing, GNU Radio, and radio telescope construction and operation. DSPIRA has a unique horn design using an F-style metal gallon container (typically used for paint solvents) and ½” foil backed foam insulation board. I’ve built a couple of these, and they work well.

In addition, DSPIRA provides excellent tutorials and other resources that you can use to learn more about hydrogen line work.

### Observing HI on the Setup

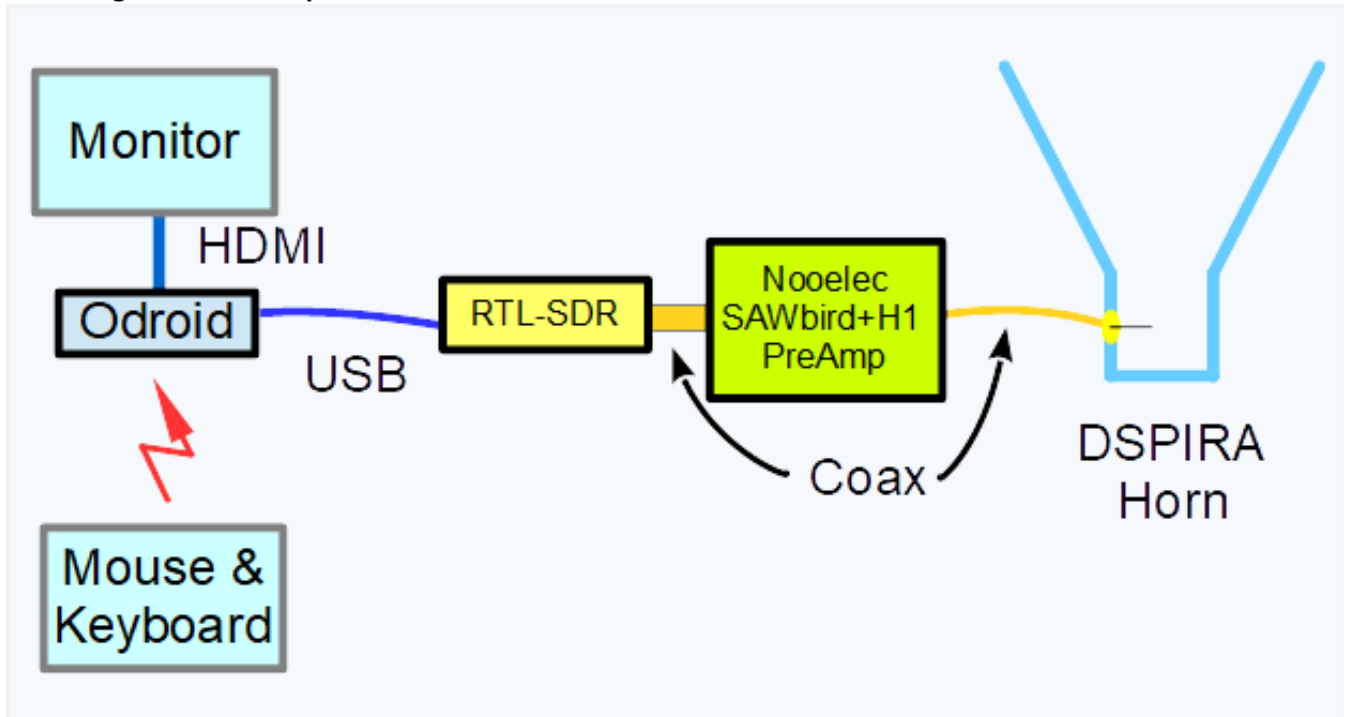

Setup Diagram

The setup for HI observing is shown in the above diagram. The band-passed Nooelec SAWbird+H1 40dB, 0.7 dB noise figure (50 K noise temperature) preamp works well with the RTL-SDR. It’s important to keep the coax from the horn to the preamp as short as possible to minimize system temperature, my coax is 6” long. There’s a male-male SMA barrel adapter between the RTL-SDR and the preamp. I have used USB cables as long as 20 feet and I haven’t noticed any problems with signals. RFI doesn’t seem to be an issue either in my suburban location. Power to the preamp is supplied through a bias-T supply from the RTL-SDR and is configured to turn on in the GNU Radio sketch.

To date I have used the telescope in drift scan mode, I like to point the horn straight up and let the Milky Way roll over my site. The plane of the Milky Way in Cygnus is straight overhead at my latitude, and this gives me a strong signal that shows up well on the display. The other side of the galaxy rolls by around 12 hours later and gives a weaker signal.



**My DSPIRA Horn**

### **Conclusions and Future Plans**

So, this was an interesting project, and it can serve as a low-budget entry level project for teachers and hobbyists. At the time of writing, the Odroid is priced at \$53.00 on the HardKernel site, you'll need a 5VDC, 4A power supply for power. The Nooelec Sawbird+H1 costs \$44.95 on the Nooelec site. Budget around \$75 for the horn parts and miscellaneous cable, adapters, Odroid case and so on. You'll need an HDMI monitor, mouse, and keyboard, ideally wireless, with a USB wireless adapter for the Odroid. Most people have these lying around, but if not, another \$75 should cover these expenses.

The Odroid gives me another possibility for observing HI emissions along with an Ubuntu laptop and my Windows 11 laptop using the SDR# application that's used for SARA's "Scope In A Box" project. I've taken the Ubuntu and Win11 setups to a number of local star parties and it's nice to have a unique one-of-a-kind display along with the dozens of optical telescopes that populate these events. People are very curious about radio astronomy and most of them haven't seen an operational radio telescope. I plan to use the Odroid to run a parallel display with a laptop to show the public different simultaneous views of the galactic plane. Another plan is to attempt installing GNU Radio using the Android operating system. Eventually I want to do some science demonstrations with my HI setups showing galactic rotation speeds at various points along the galactic plane from the center to the outer edge of the galactic disk.

## References:

- [1] HardKernel Website: <https://www.hardkernel.com/>
- [2] GNU Radio Website: <https://www.gnuradio.org/>
- [3] DSPIRA Website: <https://wvurail.org/dspira-lessons/>
- [4] Telescope Software Setup: <https://wvurail.org/dspira-lessons/categories/telescope-software-setup/>

## APPENDIX

### Installing Ubuntu 20.04 MATE onto the XU4

Download a copy of Ubuntu 20.04 MATE for the XU4 from the HardKernel website [1]. At the time of the writing, I used this image: *ubuntu-20.04-5.4-mate-odroid-xu4-20210113.img.xz*. Newer images of 20.04 may be available by the time you read this.

Using Balena Etcher or its equivalent, burn the image onto an SD card. I used a 64GB card, you should be able to get by with as little as 16 GB as my installation only occupies 8.5 GB of the card. Insert the card into the XU4, make sure the memory select switch is set to the SD position and power up the XU4. Log in with the default user/password combination of *odroid/odroid*. Open a terminal window and execute these commands to update the local repository and install the newest software:

```
$ sudo apt update
$ sudo apt upgrade
```

### Installing GNU Radio and the `gr-radio_astro` Package onto the XU4

Go to the DSPIRA “Telescope Software Setup” page [4]. Copy and paste these commands into the terminal window (explanations for what the commands do are given on the page):

```
$ sudo apt install gnuradio gr-osmosdr airsipy python3-h5py python3-ephem git cmake liborc-0.4-dev -y
$ git clone https://github.com/WVURAIL/gr-radio_astro.git
$ cd gr-radio_astro
$ git checkout gr38
$ mkdir build
$ cd build
$ cmake ..
$ sudo make
$ sudo make install
$ cd ~
$ nano .bashrc
```

Scroll to the very bottom of the file, add a blank line, and copy/paste the following code:  
`export PYTHONPATH=/usr/local/lib/python3/dist-packages:/usr/local/lib/python3.8/dist-packages:$PYTHONPATH`

Close nano and save the `.bashrc` file.

```
$ gnuradio-companion
```

When GNU Radio Companion opens,

Check which python is the installed version of GNU Radio by opening `gnuradio-companion` in a terminal window and click on Help --> About and noting the python version on the dialog box that opens.

In the terminal window, go to the following by typing either of the following, depending on whether your version of GNU Radio is using Python 3.8 or Python 3.9:

```
$ cd /usr/local/lib/python3.8/dist-packages
```

**or**

```
$ cd /usr/local/lib/python3.9/dist-packages
```

 for the appropriate python version.

```
Type ln -s /usr/local/lib/python3/dist-packages/radio_astro
```

Test the installation by starting GNU Radio Companion:



\$ gnuradio-companion

When GNU Radio Companion starts, open File→Open →gr-radio\_astro→examples

→DSPIRA→spectrometer\_w\_cal.grc and press the Start triangle in the top menu bar. If everything's ok, you will see the graphic spectrometer window open up and run.

# Comparison of Inexpensive 10 MHz GNSS Disciplined Oscillators

Whitham D. Reeve

## 1. Introduction



This article compares six inexpensive 10 MHz GNSS Disciplined Oscillators, or GDO, that are used as a reference frequency source. A GNSS is a *Global Satellite Navigation System* of which the *Global Positioning System*, GPS, is the most familiar. In 2017 I evaluated some 10 MHz reference frequency distribution amplifiers {Reeve17} and mentioned a future review of GDOs. I hereby fulfill my intention for that review.

This article is not a comprehensive review; I investigated the GDOs only enough to determine the characteristics that were important to me: Basic frequency statistics; Output signal characteristics; Form factor and dimensions; and Operating voltage and current. My application is the 10 MHz reference frequency input to the software defined radio receivers used in my observatories.

## 2. Basic GDO Operation

The two most important characteristics of a frequency source are accuracy and stability (figure 1). Accuracy is the measure of how far a frequency is from its true, or nominal, value. Stability is the measure of the variation in accuracy over a period of time. The accuracy can be no better than the stability.

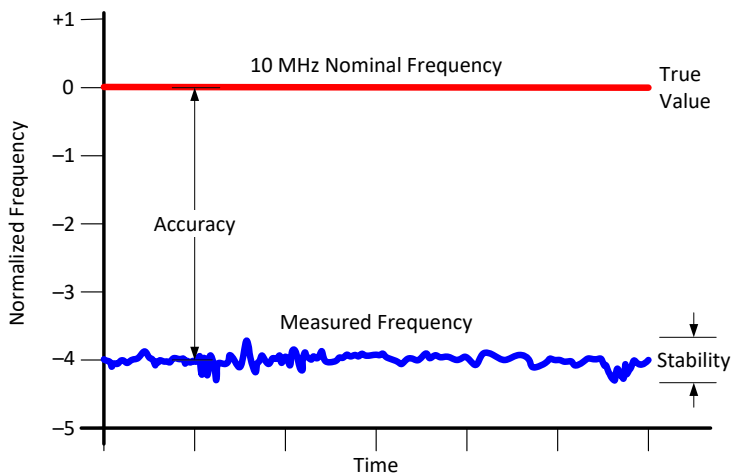

Figure 1 ~ Accuracy and stability of a hypothetical 10 MHz frequency source. The true, or nominal, frequency is shown as the straight red line and the actual oscillator frequency measured over time is shown as the jagged blue line. The stability is a statistical measure of the variations over time and is usually based on a modified version of the Standard Deviation called Allan Deviation (ADEV).

A frequency source consisting only of a quartz crystal generally has very good short term but poor long-term accuracy and stability due to aging and environmental factors such as vibration, humidity and temperature. On the other hand, a frequency source derived from a GNSS but without a quartz crystal has very good long term but poor short-term accuracy and stability due to jitter and wander. Combining a high-quality crystal oscillator and GNSS receiver provides an almost ideal frequency source that has both high accuracy and high stability. The combination is known by various abbreviations including GDO, GNSSDO and GPSDO.

The oven-controlled crystal oscillator (OCXO) and temperature compensated crystal oscillator (TCXO) provide better performance than ordinary crystal oscillators. Rubidium oscillators also are used in GDOs, particularly GDOs

that have a *holdover* function. The atomic transitions in a rubidium oscillator *physics package* are used with an RF synthesizer and voltage controlled OCXO to maintain frequency accuracy and stability. None of the units reviewed here use a rubidium oscillator, which is generally more stable but far more expensive than any OCXO or TCXO.

Of course, an oscillator and GNSS receiver cannot be simply slapped together and expected to provide textbook performance. A GDO’s performance depends on both internal and external factors. Important internal factors are the quality of the oscillator, the design of the phase locked loop that controls the output frequency and how the GNSS receiver is linked to the oscillator. External factors include signal loss, interference or other disturbances that can cause loss of receiver tracking and jumps in satellite carrier -phase measurements by the receiver. None of the sellers provided any information about the design of the GDOs but I do recall seeing a useless blurry block diagram in one of the listings.

GDOs of the type reviewed here that cost less than 200 USD typically contain old, recycled oven-controlled crystal oscillators (OCXO) and have no documentation. Many do not even have a brand or model number. They are not going to perform as well as far more expensive industrial units. Note that the cost of a new OCXO exceeds the cost of any one of the GDOs reviewed.

### 3. GDO Descriptions

This section provides information on the six GDOs in terms of the type of oscillator and types of GNSSs supported (table 1). In addition to the GPS, several other GNSS exist including Galileo, GLONASS, Beidou, and QZSS. In some cases, the GNSS must be specified at the time of purchase so the receiver can be programmed appropriately. Although receivers exist that can simultaneously acquire and track all GNSS constellations, the GDOs reviewed here apparently do not have that capability.

Table 1 ~ GDO units being compared. The serial number is an arbitrarily assigned house number. The oscillator manufacturers and model numbers in parentheses were read from the device after removing the GDO enclosure.

Model	S/N	Oscillator, 10 MHz	GNSS as advertised (1)	Remarks
BG7TBL-D	001	OCXO (Trimble 72345)	GPS, Galileo	LCD (2)
SatTime	002	OCXO (CTI OC12SC36B)	GPS, BDS, GLONASS, GALILEO, QZSS	(3)
TM4313	003	OCXO (CTI OC5SC25)	GPS, BDS	
TM4313	004	OCXO (CTI OC5SC25)	GPS, BDS	
Mini Precision GPS Reference Clock	005	TCXO (unknown)	GPS, BDS, GLONASS, GALILEO	Abbreviated MPGPSRC
PLL-GNSSDO	006	OCXO (CTI OC12SC36A)	GPS, GALILEO	

Table notes: (1) Not verified; (2) Not an actual model number; see text; (3) Not an actual model number; see text.

The next three sections describe the test setup, evaluation results and a set of images showing the units and their output spectra. All units evaluated cost between 100 and 200 USD and represent only a few of the many different GDOs available from online sellers (primarily located in China).

### 4. Test Setup

Frequency measurements were made with a recently calibrated Keysight 53220A frequency/period counter. Other equipment used in the evaluation included a Siglent SSA3032X spectrum analyzer and SPD3303X variable power supply. All measurements were made in a lab environment at a very stable temperature near 20 °C.

The reference frequency input to the counter was provided by the 10 MHz output from a Symmetricom TimeSource 2500 *GPS Primary Reference Source*, a late 1990s industrial unit used in telecommunications applications. The antenna for this unit was located adjacent to an east-facing window with numerous trees outside that partially block the view of the sky.

The TS-2500 has a 1999 vintage GPS receiver that is not very sensitive compared to modern GNSS receivers. As a result, the TS-2500 spent most of the time (about 80%) in *holdover* mode during which the unit's output frequency was determined by a rubidium oscillator. The rubidium oscillator's output frequency is corrected by historic GPS reception data and is very accurate and stable but is not as accurate as when the unit is tracking satellites over a long period. The TS-2500 in combination with the high quality of the frequency counter itself provides a very stable measurement platform. While it may not be as accurate over the long term as a GNSS disciplined oscillator that is actively tracking satellites, I believe it is far more stable than the cheap GDOs evaluated here. Nevertheless, I have not used the estimated stability (ADEV) in my evaluation.

All GDOs were supplied with an active patch-type GNSS antenna of similar design. I used one of these antennas with the GDOs. It was located 2.5 m from the lab workbench in view of the east-facing window. Even though the window does not have a clear view of the sky, as pointed out above, the modern receivers used in the GDOs are very sensitive and always were able to obtain a fix and track multiple satellites (all GDOs have an LED indicator for satellite tracking).

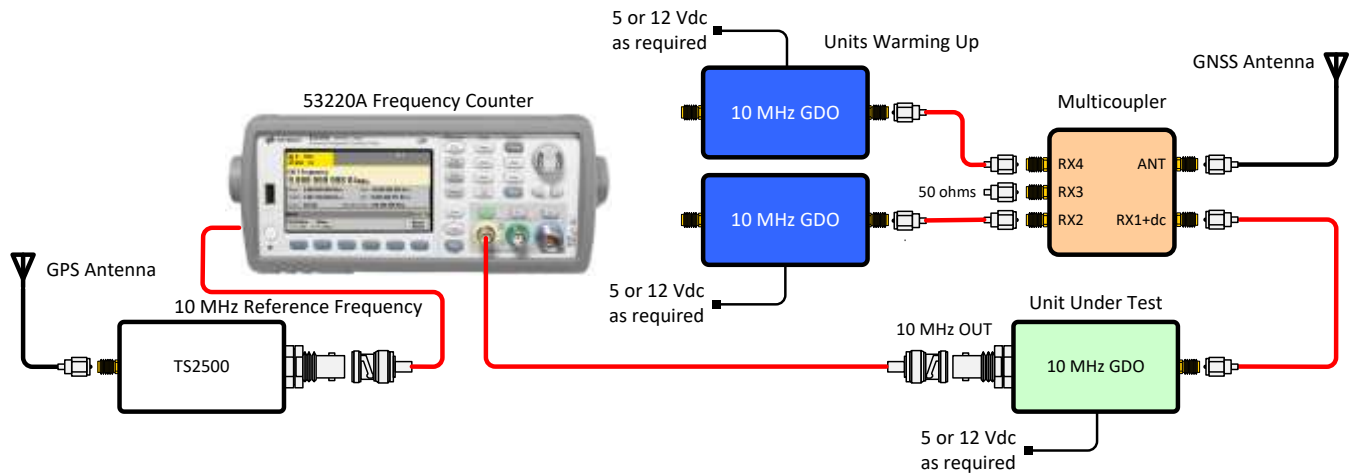

Figure 2 ~ Block diagram of measurement setup. The Unit Under Test (UUT) provides powering voltage to the active GNSS antenna while the other units are warming up and tracking for at least 24 hours. The GDOs were rotated through so that all eventually powered the GNSS antenna as part of the evaluation. Because the frequency counter and UUT used separate receivers and antennas, they operated plesiochronously.

The GNSS antenna was connected through a receiver multicoupler (active 4-port RF splitter) to allow multiple GDOs to track satellites and warmup while awaiting connection to the frequency counter (figure 2). Statistics were collected from the frequency counter for each GDO after at least 24 h of locked satellite operation. Other information was collected including dc input voltage and power plug requirements, start and run current, output spectra from 0 to 200 MHz (20<sup>th</sup> harmonic), and 10 MHz fundamental output power into a 50 ohm load.

## 5. Evaluation

General characteristics: Operational information and features are described for each GDO in this section. Basic dimensional and electrical details are listed in table 2.

Table 2 ~ General characteristics. Dimensions do not include connectors.

GDO	Power Connector	Voltage (Vdc)	Start (A)	Run (A)	Serial Interface	Dimensions (WxHxD, Wt)	Remarks
BG7TBL-D-001	2.1 x 5.5 mm	12	0.56	0.28	DB-9F	107 x 55 x 153 mm, 0.7 kg	Includes LCD
SatTime-002	2.5 x 5.5 mm	12	0.60	0.26	DB-9M	134 x 47 x 123 mm, 0.4 kg	Includes NTP server
TM4313-003	2.1 x 5.5 mm	5	0.78	0.34	Micro-USB	72 x 26 x 110 mm, 0.2 kg	
TM4313-004	2.1 x 5.5 mm	5	0.78	0.34	Micro-USB	72 x 26 x 110 mm, 0.2 kg	
MPGPSRC-005	Mini-USB	5	0.11	0.11	Mini-USB	73 x 40 x 17 mm, 0.05 Kg	Variable frequency output
PLL-GNSSDO-006	2.1 x 5.5 mm	12	0.53	0.16	3.5 mm	64 x 24 x 104 mm, 0.18 kg	Also marked BG7TBL

Brand: The BG7TBL-D does not have a model number or any other markings, but some similar looking units sold through eBay and Aliexpress are marked with a date that apparently indicates when it was designed or manufactured. The PLL-GNSSDO also is marked BG7TBL. It apparently was designed or manufactured by the same entity, but it has a completely different form factor than other units with this marking. The TM4313 is unbranded but I believe it is manufactured (or marketed) by a company called TZT in China. Two TM4313 units were evaluated. The SatTime unit has neither a brand nor model number or any other markings. The Mini Precision GPS Reference Clock (abbreviated MPGPSRC from now on) is manufactured by Leo Bodnar Electronics, which is based in Britain and sold direct or through SDR-Kits.net.

Documentation: None of the units included instructions or a user guide of any kind. The minimal online information provided nothing more than repetition of GNSS operational specifications, if that, and no specifications for the actual GDO itself. The MPGPSRC at least has a dedicated webpage with some performance and operation information as well as a software tool for checking satellite tracking and setting the output frequency; some additional application information for this unit is available at {[Reeve20](#)}. The MPGPSRC also has upgradeable firmware, something none of the others have or, if they do, it is not advertised.

Load current measurements: All units except the MPGPSRC have an OCXO, which draws more current during starting and warming up than when running. Starting current is the important value because the external power supply must support it. All units with an OCXO showed the same behavior when first powered – the starting current ramped up over several seconds to a peak value and after a few minutes it quickly dropped to the running value.

Another characteristic that affects the current draw is the GNSS receiver transition from searching to tracking satellites. The search function requires more power. I made no attempt to separate the current draw during search and track functions because the difference is small compared to the starting and running currents of the OCXO.

Display and indicators: All units have LEDs that indicate power status, satellites in view (SV) status and satellite fix or tracking status, either through dedicated or blinking LEDs. Only the BG7TBL-D has a liquid crystal display (LCD). The LCD indicates frequency and other information; however, there is no way to turn off or dim the LCD backlight or turn off the display itself without disconnecting the internal LCD cable.

Serial port interface: The BG7TBL-D, TM4313 and PLL-GNSSDO have a serial port interface for monitoring NMEA messages from the receiver, but none had instructions on how to use it or how to read the messages. NMEA

messages are handy for determining position coordinates and satellites in view and could be used to verify the GNSS that seller advertisements claim the unit uses. The NMEA message type *GSV* identifies the GNSS satellites in view and the number of each. The message is prefixed with GP (GPS), GA (Galileo), GL (Glonass), GB or BD (Beidou), GQ (QZSS) or GN (combined). Many online resources define the various other NMEA messages.

The BG7TBL-D and TM4313 have DB-9F connectors, and the PLL-GNSSDO has a 3.5 mm audio-style jack used for serial communications. I was able to connect to the first two units with the PuTTY software tool, a USB-Serial Converter, straight-through serial cable and 9600, 8N1 COM Port settings and view the NMEA messaging without problems. I have many serial cables that use the 3.5 mm connector, but these would not work with the PLL-GNSSDO unless a null modem adapter was inserted between the unit and cable (RXD and TXD on one end of the cable is swapped). These three units tracked numerous satellites with the indoor antenna as described in section 4.

The SatTime has a DB-9M connector marked RS422, but the pinout is undocumented. I was not able to successfully connect to the SatTime unit and did not spend any time trying to determine the connector pinout or any other details about it other than a failed attempt to contact the seller. The MPGPSRC uses a special software tool and does not provide NMEA messaging, but it does show the number of satellites in view and if they are being used in the frequency calculations. The MPGPSRC uses an ordinary USB cable with a Mini-USB connector for serial communications and required no driver installation.

Other functions: Some GDOs have additional outputs including Inter-Range Instrumentation Group (IRIG) timecodes and 1 pulse-per-second (1 PPS), but none of these apply to my immediate needs so I did not evaluate them. The captions on the images in section 6 name the outputs available from each device.

The SatTime unit has a modular jack marked *Ethernet* for its built-in Network Time Protocol (NTP) server function. This means the one unit provides two important functions, a 10 MHz reference frequency source and NTP server. I verified the NTP server functionality by searching the LAN for an unfamiliar IP address and then configuring the NTP client on a PC to use that address. I could not connect to the SatTime's internal web browser interface (if it has one), and the eBay seller did not respond to my inquiries about the unit.

Satellite constellations: The product listings on eBay and Aliexpress indicate the GNSS constellation used by the unit. With some units, either one or two GNSS constellations are to be specified by the buyer during purchase. When given the choice, I chose GPS and Galileo, but I did not verify during evaluation that specific satellite systems were actually being used (successfully tracking satellites was sufficient for my application).

GDOs used in industrial applications are generally designed to meet frequency specifications with only one satellite in view, although some units have increased accuracy with more. The meager information provided with the inexpensive GDOs evaluated here does not specify anything related to satellite-in-view quantity or quality.

10 MHz Oscillator: The 10 MHz output signal from all GDOs is generated by an OCXO except in the Mini Precision GPS Reference Clock. The OCXO in the BG7TBL-D and SatTime units have a well-used physical appearance (scratched or tarnished) and are made by Trimble or CTI. The PLL-GNSSDO uses the same oscillator as the SatTime (CTI) but its physical appearance is much better. The physical appearance of the OCXOs in the TM4313 is better than average.

These oscillators probably were salvaged from obsolete base transceiver stations used in the old 3G cellular systems and probably are *aged out* (that is, natural crystal aging has drifted the crystals beyond their specified frequency limits). Surprisingly, I could not find datasheets for any of the OCXOs, but they have a standard pinout

and layout (footprint). The CTI oscillator part number appears to indicate basic characteristics. For example, the CTI OC12SC36B is Oven Controlled (OC) with 12 V operating voltage, SC cut crystal and the long dimension is 36 mm.

The SatTime unit had a noisy OCXO and worked much better after I replaced it (discussed more below and in section 6). Replacing the used OCXOs with new (or newer) devices would likely improve the performance of the other GDOs.

The MPGPSRC advertisements claim it uses a temperature compensated crystal oscillator, TCXO (it is not visible on the unit's PCB). The TCXO works with a synthesizer to provide an output. Although the measurements show the MPGPSRC to have good performance in my lab, which has a constant temperature, the MPGPSRC may not provide performance comparable to a GDO that uses a good OCXO over the operating temperature ranges of my remote observatories (the indoor temperature in my Coho Radio Observatory can reach  $-20^{\circ}\text{C}$  during winter).

Workmanship: All GDOs are built on professionally made printed circuit boards and all surface mounted devices appear to be machine-soldered. Surface mounted devices generally are installed on the lower layer with through-hole components (for example, the OCXO and connectors) on the top layer.

Design: There is a potential design problem with all units except the MPGPSRC, and that is the lack of margin in the GDO input voltage compared to the OCXO operating voltage. The voltage range of OCXOs typically is the specified nominal voltage  $\pm 5\%$ . For example, for a 12 V operating voltage the input range would be 11.4 to 12.6 V, and for a 5 V nominal input, the range would be 4.75 to 5.25 V. Assuming all units have a polarity guard diode, the OCXOs in units with 5 V input voltage probably are operated below the recommended range and units with 12 V input voltage are operated with little or no margin, both because of diode voltage drop.

It is possible some units do not have a polarity guard diode on the power input, but the PLL-GNSSDO does (type SS24 Schottky diode). Further investigation of this unit showed that the oscillator voltage was 11.6 V with 12.0 V at the GDO's power jack. This provides very little margin for variations in the power supply. The margin for this unit may be improved by raising the input voltage to, say, 13 V. Interestingly, the marked input voltage range for the PLL-GNSSDO is 11.4 to 13 V, although the low end is obviously too low. All units are supplied with a regulated ac adapter power supply, either 5.0 or 12.0 Vdc.

The OCXOs in the GDOs have an electronic frequency control (EFC) pin that allows the frequency to be steered over a small range (typically around  $\pm 1$  ppm or less) to compensate for aging and other drift mechanisms. Presumably, the EFC is ultimately controlled by the 1 PPS signal from the GNSS receivers. I noted that the control voltage on the PLL-GNSSDO was near mid-voltage (6 V) at startup and generally stayed near 1.95 to 1.97 V when tracking satellites. The 12 V OCXOs familiar to me have a full EFC range of 0 to 12 V, so this unit operates near one end of its range at room temperature.

Frequency measurements: All units supplied a 10 MHz output signal when initially powered but with varying amounts of inaccuracy (a satellite fix was not necessary for the unit to provide an output, unlike some industrial units). The frequency drifted as the oscillator warmed up to a running state but before a satellite fix was obtained. After a satellite fix, the frequency appeared to lock into a final nominal value with a small amount of variation as the oscillator stabilized over the next several hours. All oscillators showed tiny frequency variations in the mHz or  $\mu\text{Hz}$  range after warmup.

I was more interested in comparative frequencies than absolute frequencies. The 53220A frequency counter is easily setup to collect the following statistics: Mean frequency ( $F_{\text{avg}}$ ); Standard deviation ( $\sigma$ ); maximum ( $F_{\text{max}}$ )

and minimum (Fmin) frequency and Allan Deviation (ADEV). These were collected over a period of at least 24 h for each unit (table 3).

Table 3 ~ Statistics after 24 h of satellite tracking. All parameters except  $\Delta F$  and Pout were obtained directly from the frequency counter.  $\Delta F$  is computed as the difference between Fmax and Fmin. Pout was obtained from the spectrum analyzer and is for the fundamental only. ADEV measurements are based on  $\tau = 1$  s but they do not provide a useful comparison because of the measurement setup.

GDO	Favg (MHz)	$\sigma$ ( $\mu$ Hz)	Fmax (MHz)	Fmin (MHz)	$\Delta F$ (nHz)	ADEV ( $\mu$ Hz)	Pout (dBm)
BG7TBL-D-001	9.999 999 999 97	293	10.000 000 001 4	9.999 999 998 81	2.59	218.7	12.30
SatTime-002	9.999 999 999 97	2808	10.000 000 012 1	9.999 999 987 60	24.5	2714.7	9.91
SatTime-002 (1)	9.999 999 999 97	944	10.000 000 008 8	9.999 999 994 14	14.7	91.6	10.16
TM4313-003	9.999 999 999 98	2067	10.000 000 028 8	9.999 999 977 87	50.9	249.5	10.66
TM4313-004	9.999 999 999 98	1867	10.000 000 025 6	9.999 999 981 48	44.1	236.9	10.60
MPGPSRC-005 (2)	9.999 999 999 90	636	10.000 000 006 2	9.999 999 997 36	8.84	522.2	8.43
PLL-GNSSDO-006 (3)	10.000 000 000 0	833	10.000 000 004 7	9.999 999 995 00	9.70	168.6	12.08

Table notes:

- (1) Measurements were after OCXO replacement described in section 6. For these measurements, the frequency counter reference was changed to the All-in-One package described in section 7 so is different than the previous measurements for this unit;
- (2) Pout from the MPGPSRC was with an output drive setting of 8 mA;
- (3) The frequency counter reference was changed to the All-in-One package described in section 7.

The mean frequency was not important to me (other than as a cross-check) because of the measurement setup and limitations described above, but the other parameters and the difference between maximum and minimum frequency ( $\Delta F$ ) provided the information I needed. Allan Deviation (ADEV) is an important stability measurement and was recorded as part of the statistics. However, because the reference frequency source for the frequency counter was not always tracking satellites, the meaning of the ADEV measurements was not clear to me and was not used in the evaluation.

10 MHz output spectra: Some GDOs have both sinewave and squarewave outputs. A squarewave has the fundamental frequency as well as numerous harmonics and can be considered to be a very distorted sinewave. I require a low distortion sinewave output to prevent equipment that uses the external reference from locking onto the wrong frequency and also to reduce the number of spurious signals in my lab.

The spectra varied with the type of OCXO as shown in the spectrogram images in the next section. For some applications, the output from a unit with a distorted sinewave or squarewave output may need to be externally filtered to reduce the harmonics. More sophisticated equipment has built-in filters for this purpose.

Note that a 20 dB attenuator was placed on the spectrum analyzer RF input to reduce the chance of damage due to high power, so the vertical scale on the display uses a 20 dB offset to compensate.



## 6. Images

BG7TBL-D-001:



Figure 3.a ~ Left: System PCB connected by a ribbon cable to the LCD at bottom of image. Most components are underneath the system PCB. The Trimble OCO is the large square can in the lower-left of the PCB. Note the well-used and worn appearance of the oscillator. The outputs, antenna input, dc power input jack, serial port interface and LED indicators are on the back panel at the top of the image. The outputs are 1 PPS and 10 MHz sinewave. Right: View of the front panel with the LCD (unpowered).

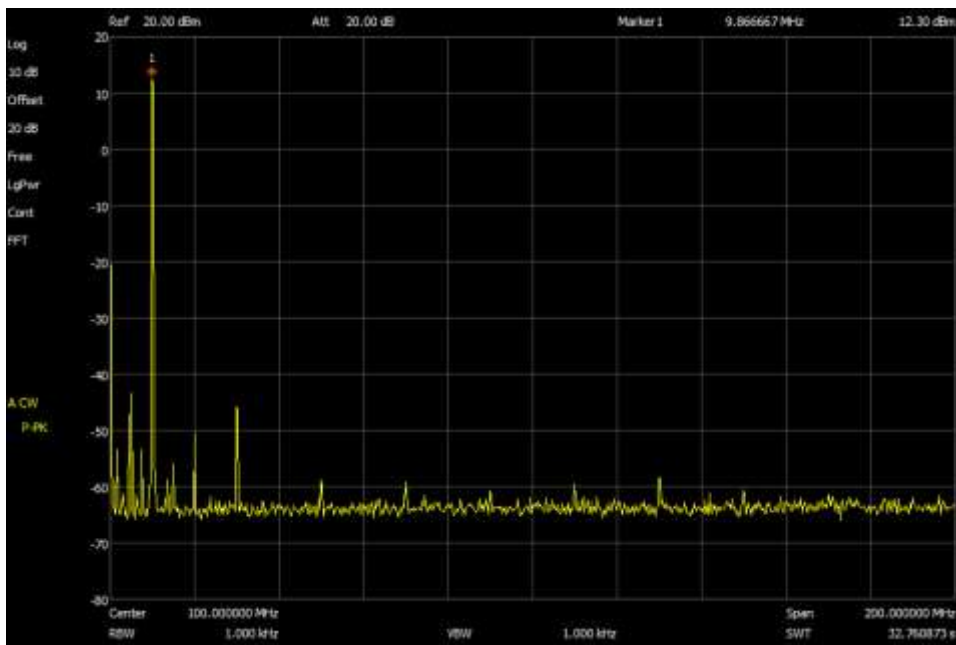

Figure 3.b ~ BG7TBL-D output spectra from 0 to 200 MHz. A 5 MHz subharmonic exists at about  $-50$  dBc and is far enough below the 10 MHz fundamental to not be a problem. A few other spurious signals and harmonics are visible but have lower power. This unit likely would benefit from a new OCO.

SatTime-002:

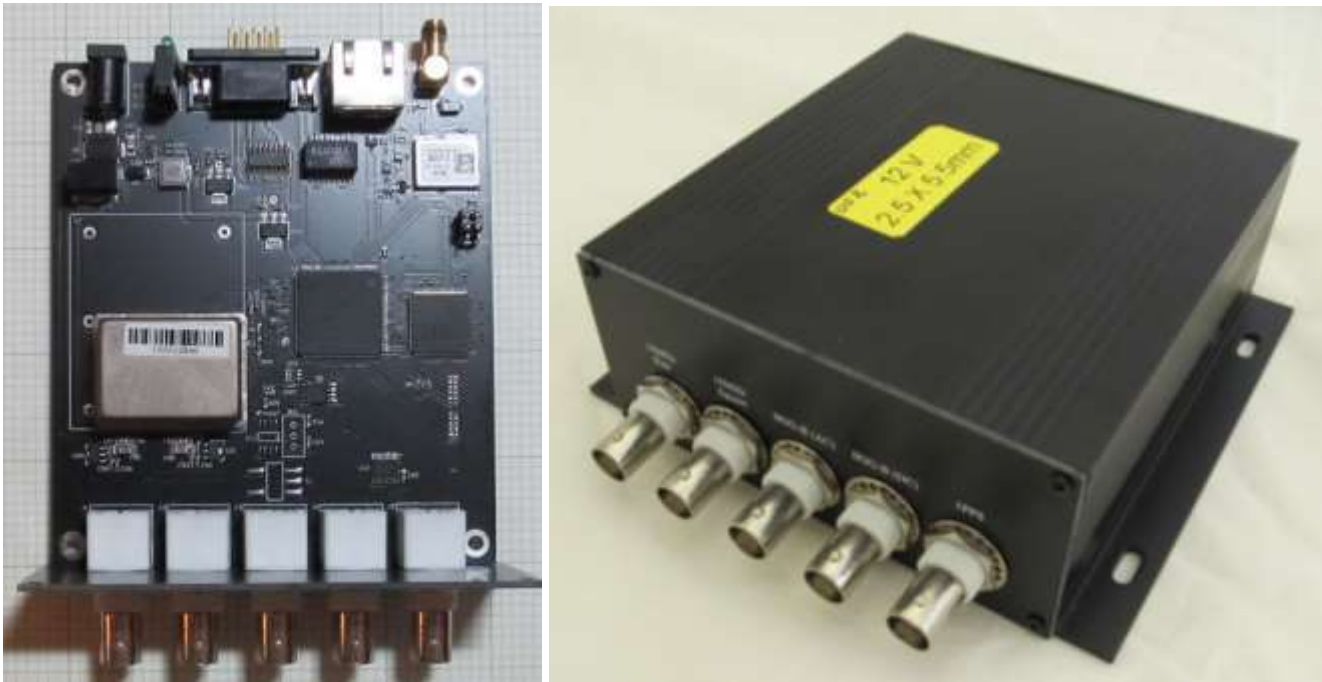

Figure 4.a ~ Left: System PCB. The OXCO is the rectangular silver can near the middle-left of the PCB. This picture was taken before the oscillator was replaced; note the tarnished appearance of the oscillator can. The outputs are at the bottom, and the antenna input, Ethernet modular jack, dc power jack, serial port interface and LED indicators are at the top of the image. Right: View of the output panel. The outputs are 10 MHz sinewave, 10 MHz squarewave, IRIG-B (AC), IRIG-B (DC) and 1 PPS. I only tested the 10 MHz sinewave output.

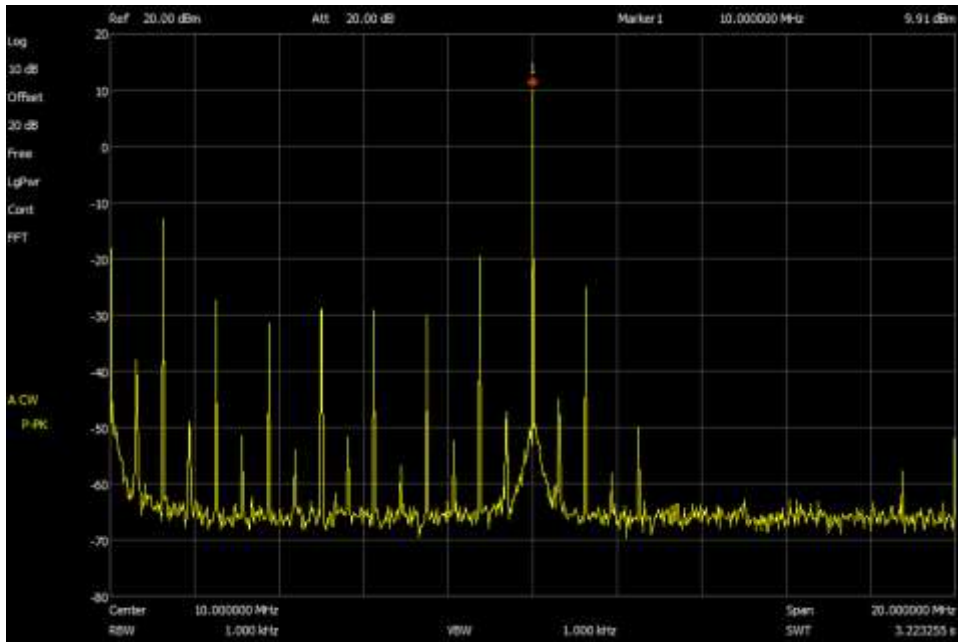

Figure 4.b ~ SatTime output spectra from 0 to 20 MHz as received. The spectra has many subharmonics of the 10 MHz output. The subharmonics start at 625 kHz and continue to over 10 MHz at 625 kHz intervals. The strongest subharmonic is 1.25 MHz at about  $-20$  dBc. The SatTime output is supposed to be a sinewave but the subharmonics indicate the oscillator is defective. The OXCO was replaced and additional measurements below show much better spectra.

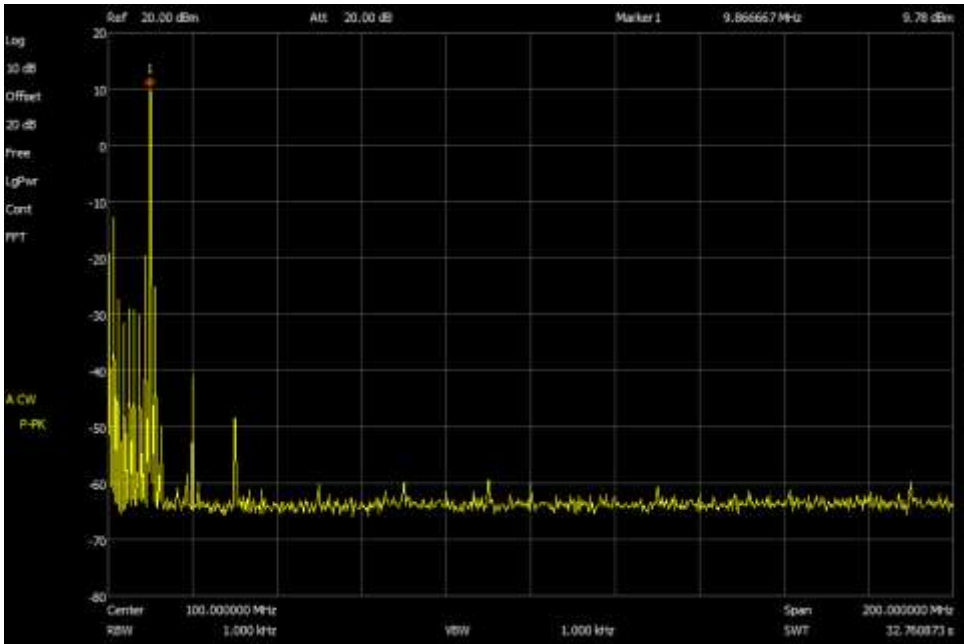

Figure 4.c ~ SatTime output spectra from 0 to 200 MHz before OCXO replacement. The output at frequencies above 10 MHz is clean compared to the subharmonics. The strongest harmonic of 10 MHz is 20 MHz at about -50 dBc.

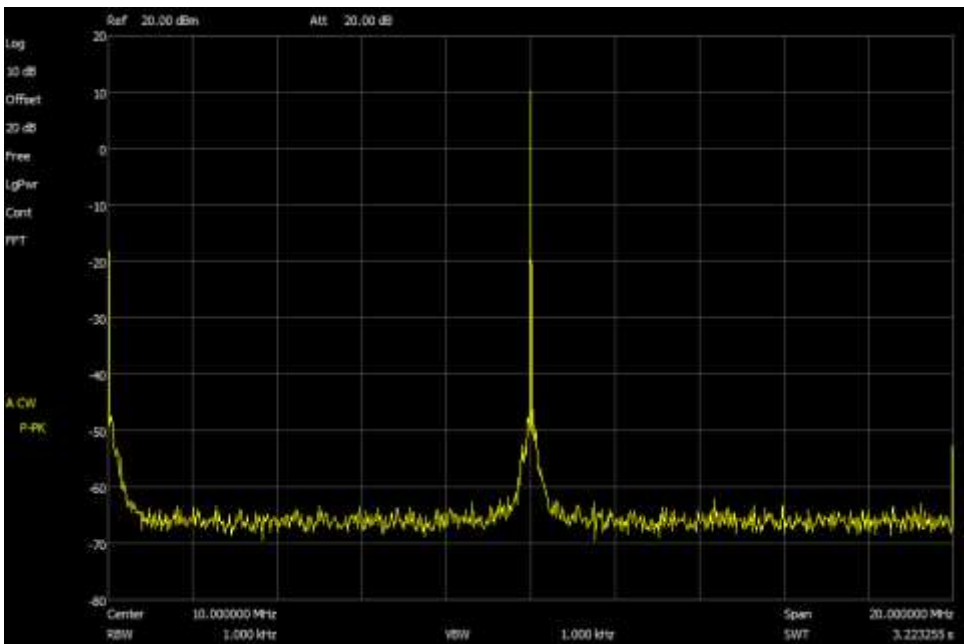

Figure 4.d ~ SatTime output spectra from 0 to 20 MHz after OCXO replacement. Note the complete absence of subharmonics.

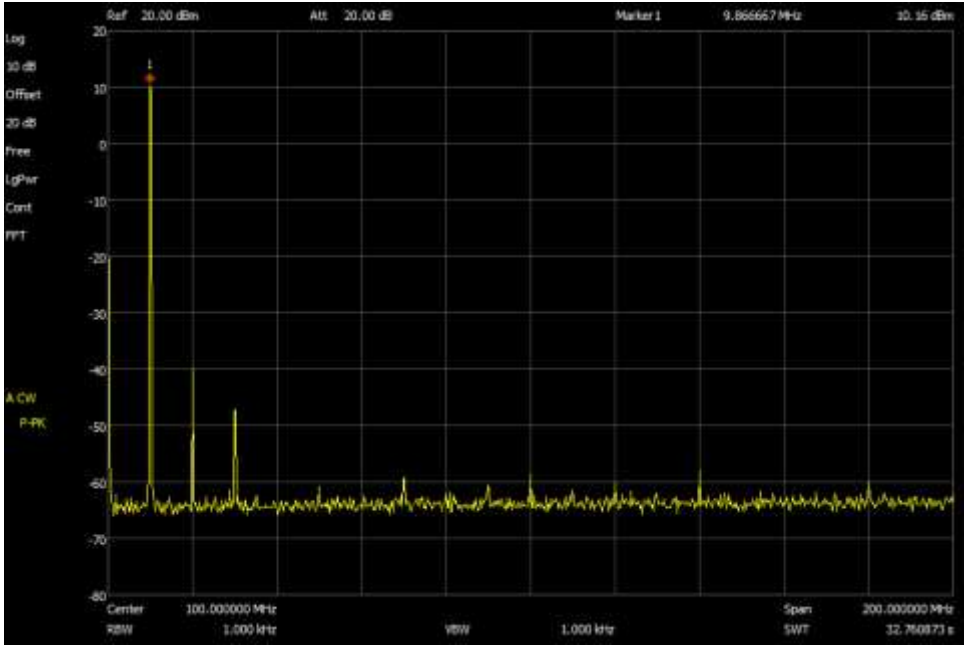

Figure 4.e ~ SatTime output spectra from 0 to 200 MHz after OCXO replacement. The spectrum from 10 to 200 MHz is the same as the original OCXO.

TM4313-003 & TM4313-004:



Figure 5.a ~ Left: System PCB for one of the two units evaluated. The OCXO is the large, square silver can; note the newer appearance than the BG7TBL-D and SatTime (before replacement). The 10 MHz and 1 PPS outputs and antenna input are at the bottom, and the dc power jack, Micro-USB connector and LED indicators are at the top of the image. Right: View of the output and antenna input panel. The outputs are 10 MHz sinewave and 1 PPS.

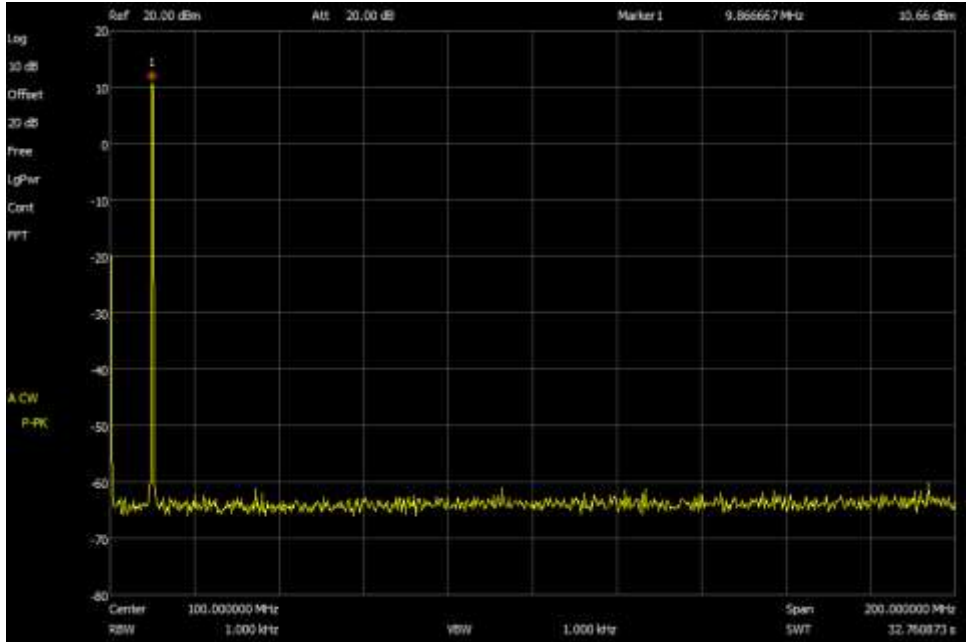

Figure 5.b ~ The TM4313 output spectra is very clean with no visible spurious signals or harmonics with a power level above  $-75$  dBc.

Mini Precision GPS Reference Clock-005:



Figure 6.a ~ Left: System PCB. The TCXO is presumably under one of the metal shields. The output is at the bottom and the antenna input and Mini-USB connector are at the top of the image. The only output is a variable frequency squarewave the frequency of which is set by the user; I set my unit to 10 MHz; Right: View of the antenna input and Mini-USB connector panel. Image source: leobodnar.com

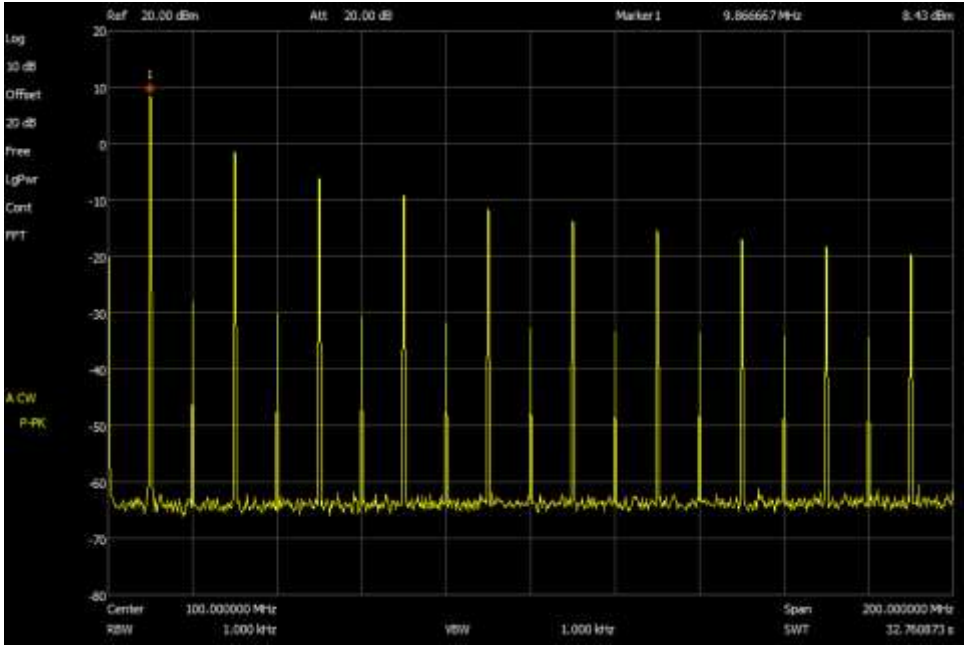

Figure 6.b ~ The MPGPSRC output spectra indicates an offset squarewave with harmonics spaced at 10 MHz intervals. The strongest harmonic is the 3<sup>rd</sup> harmonic (30 MHz) at -10 dBc.

PLL-GNSSDO-006:



Figure 7.a ~ Left: System PCB, top view showing the OCXO (rectangular silver can in the middle), which is the same model as used in the SatTime GDO. Most components are underneath and not visible in this view. The output BNC-F connectors for the 10 MHz sinewave and 1 PPS and the status LEDs are at the bottom of the image. The antenna input, 3.5 mm serial port jack and dc power input jack are at the top of the image. Right: View of the antenna input, 3.5 mm serial port jack and 12 Vdc input jack panel. The transmit and receive pins on the RS232 (EIA-232) connector are reversed from convention. PCB dimensional tolerances are not particularly good – the nuts on the RF connectors cannot be tightened without warping the panels; the PCB should be redesigned or shims should be used.

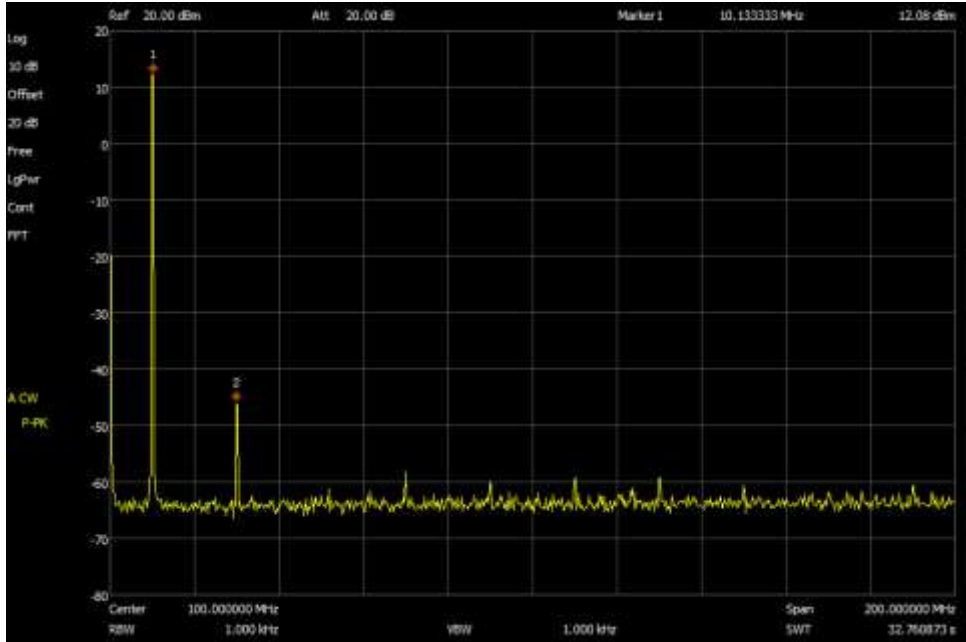

Figure 7.b ~ The PLL-GNSSDO output spectra is very clean with only the fundamental and 3<sup>rd</sup> harmonic (30 MHz) visible. The 3<sup>rd</sup> harmonic level is -58 dBc.

## 7. Discussion

The BG7TBL-D, TM4313 and Mini Precision GPS Reference Clock provide comparable performance but the SatTime (after OCXO replacement), BG7TBL-D and MPGPSRC have the smallest frequency standard deviation ( $\sigma$ ) and  $\Delta F$ . The PLL-GNSSDO performance falls in between. The MPGPSRC output is full of harmonics and, because of the need for an external lowpass filter, is not attractive in my application. The SatTime unit is attractive from the standpoint that it not only has good performance (after OCXO replacement) but it also combines an NTP server and GDO in one box. However, the unit cannot be used more fully without documentation of its features.

I prefer to rigidly mount electronic equipment in 19 in (483 mm) racks or shelves, and the less the required vertical mounting space the better. The TM4313, PLL-GNSSDO and MPGPSRC easily fit in a standard 1-unit (1U) high rack mounted enclosure or shelf, whereas the BG7TBL-D and SatTime units are taller than 1.75 in (44.5 mm) and so require 2U of mounting space. All GDOs use extruded aluminum enclosures that are easily drilled and tapped for screw mounting.

Although the MPGPSRC has better frequency statistics than the TM4313, the TM4313 probably will out-perform the MPGPSRC in other than a lab environment because of their different oscillator types. The MPGPSRC may be set to a frequency other than 10 MHz, which may be needed in some applications but not in mine.

## 8. Conclusions

Based on the above discussion, I chose to use the TM4313 GDOs for use in two shop-built, All-In-One NTP Server and GDO packages that are installed in my Anchorage lab and observatory (figure 8).

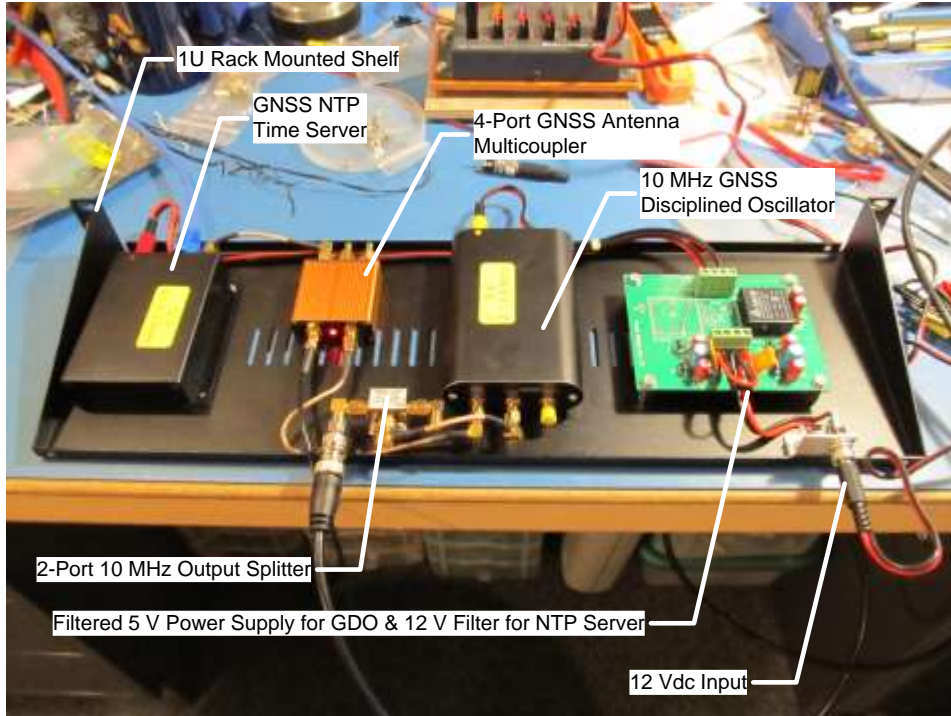

Figure 8 ~ The All-in-One under test. The TM4313 GDO (center) along with an NTP Server (left), are all mounted on a 1U x 6 in (150 mm) shelf. A 4-port multicoupler is used to allow one antenna to serve both units, and it has two extra ports for future GNSS devices. An RF power splitter is used on the GDO 10 MHz output to provide the reference frequency to two SDR receivers. Because the 10 MHz frequency reference signal is so strong (+10 dBm), it is necessary to use very high quality coaxial cables for interconnection to reduce radiated emissions from the source.

The NTP servers in the All-In-One are separate units called *FC-NTP-Mini* and supplement the GpsNtp-Pi units already on the LAN that serves the observatory and lab. The GNSS receivers in the server and GDO are connected to a single antenna through a 4-port GNSS receiver multicoupler that allows additional GNSS receivers to be connected in the future. The PLL-GNSSDO has comparable performance to the TM4312 and will be used in a third All-In-One package to be deployed at my HAARP Radio Observatory.

---

## 9. References

- {Reeve17} Reeve, W., Observatory 10 MHz Reference Distribution Amplifier, 2017, available at: [https://reeve.com/Documents/Articles%20Papers/Reeve\\_10MHzDist.pdf](https://reeve.com/Documents/Articles%20Papers/Reeve_10MHzDist.pdf)
  - {Reeve20} Reeve, W., Using the SDRPlay SDR Receivers with an External Frequency Reference, 2020, available at: [https://reeve.com/Documents/Articles%20Papers/Reeve\\_SDRPlay-miniGPS.pdf](https://reeve.com/Documents/Articles%20Papers/Reeve_SDRPlay-miniGPS.pdf)
-



## Observation Reports

### Meteor Trail Reflections Observed at Anchorage, Alaska

Whitham D. Reeve

A comprehensive study of receiver data from 2020 showed that HF meteor trail reflections (meteor echoes) of signals from the WWV and WWVH time-frequency stations were most often observed at Anchorage during the local morning {[Reeve21](#)}. The reflections fell into two categories, long duration and short duration, that indicated the length of the trace on the software used to plot the demodulated audio from the receivers. The observations below include both short and long duration echoes.

The images showing meteor echoes in figures 1 and 2 were produced by Argo software on 29 January and 4 February 2023, respectively, at Anchorage Radio Observatory with three receivers and an HF log periodic dipole array antenna. The receivers were set to the lower sideband (LSB) mode and tuned slightly offset from 1 kHz above the carrier frequencies 15 and 20 MHz (stations WWV and WWVH) and 25 MHz (station WWV only). The demodulated audio from each receiver was fed through an analog audio mixer to the soundcard Line In jack on a PC where it was processed and plotted by Argo as a narrowband (40 Hz) horizontal waterfall.

Timestamps in the Argo plots are shown at 1 min intervals (HH:MM:SS) along the bottom horizontal scale and the demodulated frequency (Hz) is shown on the right vertical frequency scale. The white traces are the demodulated carriers. The lower trace at 995 Hz in both figures is from a receiver tuned to 15.000 995 MHz, the middle trace at 1005 Hz is from a receiver tuned to 20.001 005 MHz, and the upper trace at 1015 Hz is from a receiver tuned to 25.001 015 MHz, all in LSB mode.

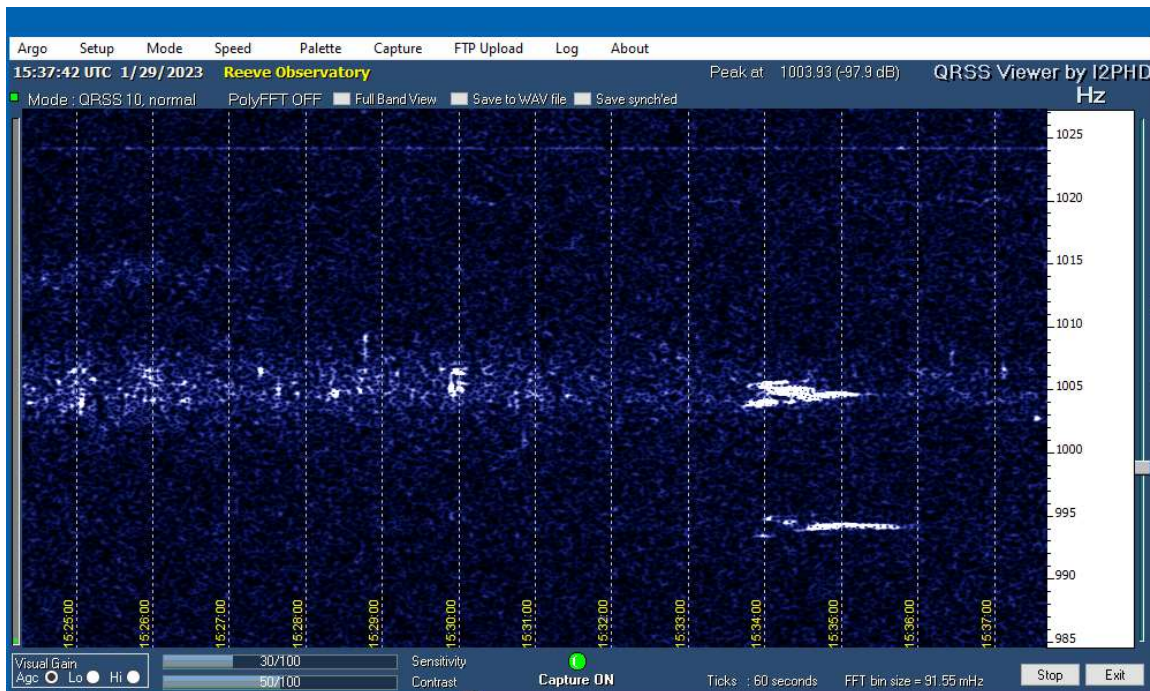

Figure 1 ~ Argo plot for 1525 to 1537 on 29 January showing weak short duration meteor echoes (blips) at 20 MHz and a single long duration echo (about 1.5 min) at 1534 (middle trace at 1005 Hz). Another long duration echo, which may be related to the echo at 20 MHz, also is seen at 1534 at 15 MHz (lower trace at 995 Hz).

The WWV transmitters are about 3800 km east of Anchorage and the WWVH transmitters are about 4400 km south of Anchorage (figure 3). The event shown in figure 1 occurred about 3 h before local sunrise and the event in figure 2 occurred about 2 h before local sunrise. It is not known which location, WWV or WWVH, was involved in these reflections, but WWVH on 15 MHz usually can be heard in the morning at Anchorage.

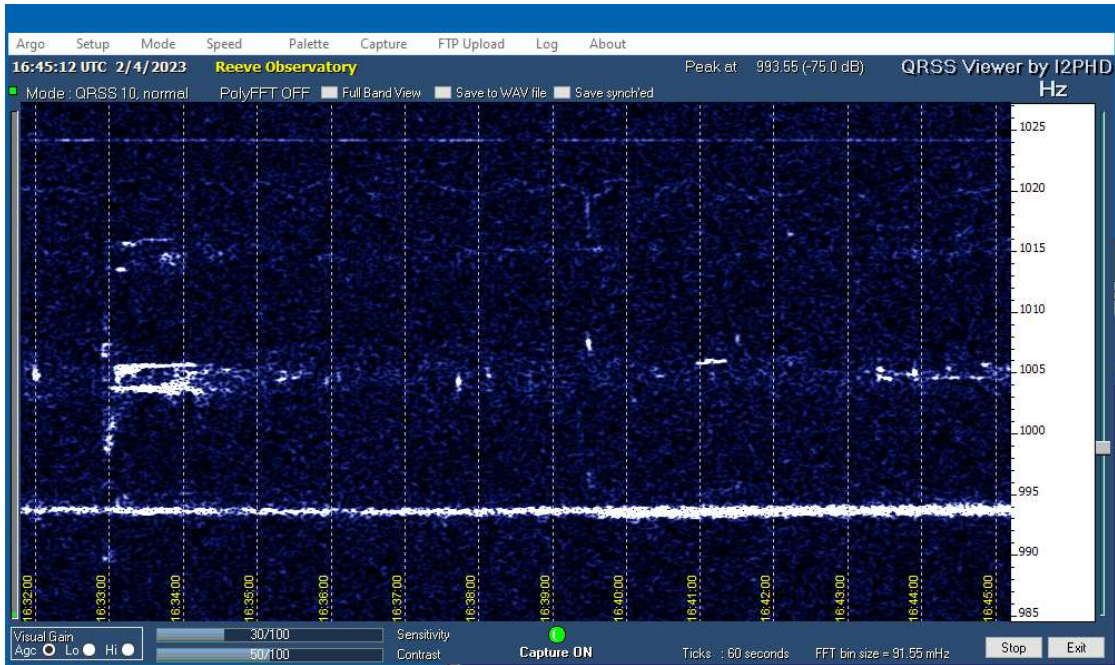

Figure 2 ~ Argos plot for 1632 to 1645 on 4 February 2023 UTC showing a long duration echo at 20 MHz (middle trace at 1005 Hz) and the vestige of an echo at the same time on 25 MHz (upper trace at 1015 Hz). A number of short duration echoes are seen at 20 MHz. The 15 MHz carrier (lower trace at 995 Hz) is continuous but very weak and shows no echoes.

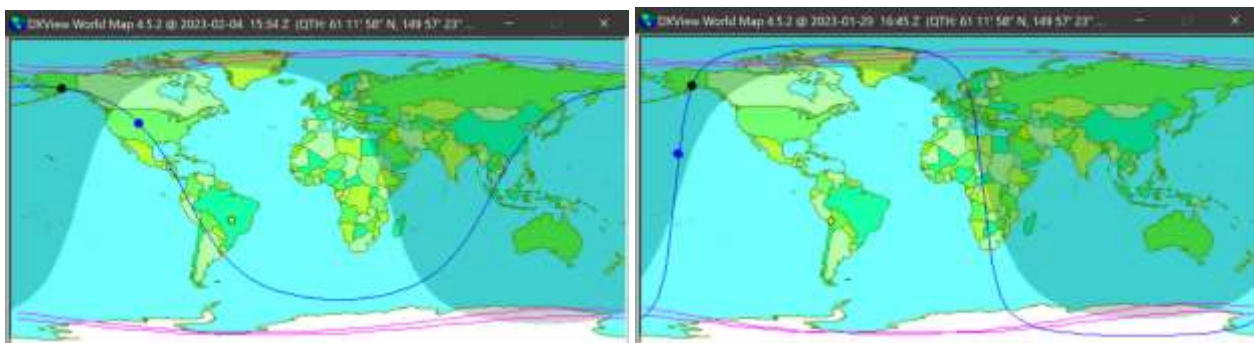

Figure 3 ~ Great circle propagation paths (blue lines), solar terminator (edge of gray area) and stations (blue dots). Left: WWV and Anchorage Radio Observatory path with the solar terminator shown at 1534 UTC on 29 January. Right: WWVH and Anchorage Radio Observatory path with the solar terminator shown at 1645 UTC on 4 February. Images from DXView.

**References:**

{Reeve21} Reeve, W., HF Meteor Trail Reflections Observed at Anchorage, Alaska, 2021, available at: [https://reeve.com/Documents/Articles%20Papers/Reeve\\_AuroraRadioObsrv.pdf](https://reeve.com/Documents/Articles%20Papers/Reeve_AuroraRadioObsrv.pdf)

## A Look at 1420 MHz Observations from Opposite sides of the Sun

---

By Charles Osborne, K4CSO

### Introduction

I thought it might be interesting to look at how much difference in doppler six months makes. I.e., from the opposite side of the Sun. So, I went searching for pairs of my observations close to the same ra/dec.



-9° Declination 7.22 ra [ 1.19° glat/ 223.70° glon]  
1420.187/1419.962/1420.080/1420.262 (taken 2/9/2023)

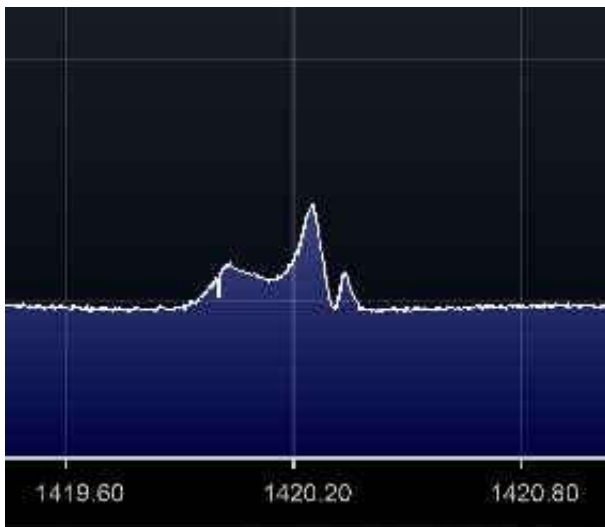

-9° Declination 7.58 ra [ 5.90° glat/ 226.26° glon]  
1420.253/1420.039/1420.343 (taken 7/28/2022)  
Delta: -0.066 MHz 6 months later at -9°dec



+35°declination 20.38 ra (-1.47°glat/ 74.31° glon)  
 1420.466/1420.610/1420.819 (taken 2/6/2023)



+36dec 20.13ra ( 1.44°glat / 73.15°glon)  
 1420.484/1420.857/1420.693/1421.009 (taken: 8/2/2022)  
 Delta : -0.018 MHz six months later at 36°dec



-29°dec 17.66ra ( 0.46°glat/ 359.51°glon )  
1420.573/1420.525/1420.889 (taken: 2/4/2023)

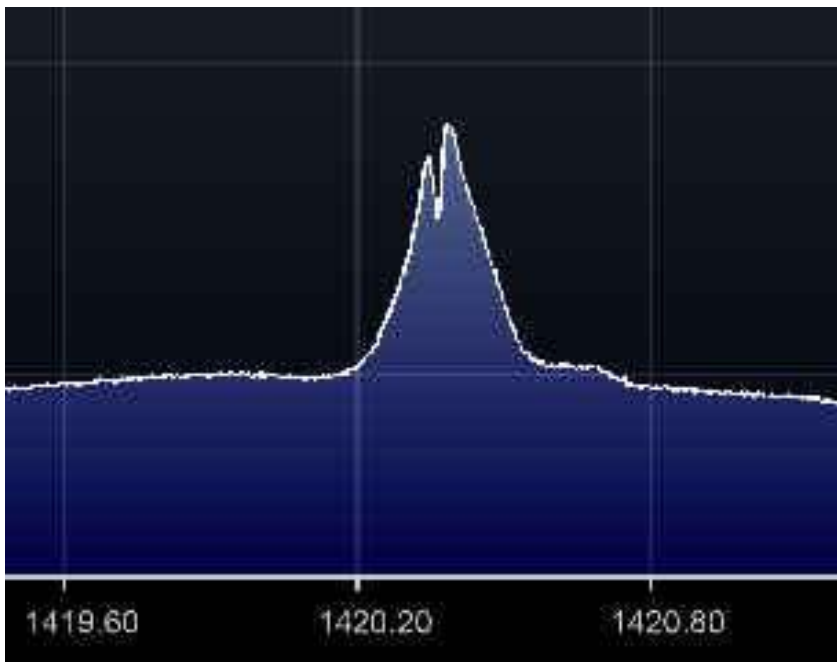

-29°dec 17.71°ra ( -0.15°glat/ 359.90°glon )  
1420.400/1420.355/1420.687 (taken: 7/15/2022 )  
Delta: +0.173 MHz six months later at Galactic center

None of the measurements are corrected for Local Standard of Rest. These are just the raw uncorrected frequencies I saw. The way I take the frequencies is in the order of the highest to lowest peaks. The graphs were just the closest ones I could find to a given galactic ridge crossing at a given declination's drift scan. Therefore, some error can be from changes in the small pointing angular differences in each pair of jpps. And also, in how I place the cursor to read the frequency peaks is subject to some difference.

The take away from this is primarily that correcting for Local Standard of Rest is necessary. The frequency changes in six months are significant and increase the closer you get to Galactic Center.

A small uncorrected factor is also the frequency accuracy of the RTL-SDR dongle. I have gone thru several over the last couple of years. So the frequency absolute accuracy may have changed due to both temperature and absolute reference crystal frequencies being different. Oddly enough, one way I know that change is fairly small is that the primary spurious signal that stays with me is 1420.000 MHz. I've seen maybe a 10 kHz lower frequency on that spur in winter than summer. Not sure where that one is coming from. But high angles cause it to show up much stronger. So that implies it is in my house. There are probably 40 microprocessors in the house which could be the culprits. I haven't spent a lot of time hunting it. It's not overwhelming between +15~-30dec so finding it has not been a priority.

The dish is a 3.7m GigaSat FA-370 carbon fiber az-el dish, set on due south, and changed in elevation every few days to capture new sets of data. I stay away from high angles when the chance of rain is high. The reason is that my dish can catch quite a lot of rain at some angles. And the hub access hole acts like a funnel guiding the water into the az-el motor area of the dish. I wish that part of the dish drained better to keep water out of the azimuth motor wiring and gears. It was originally waterproofed. But at 17 years old a few things need inspecting and new waterproofing.

I need to disassemble the dish and investigate whether something is being damaged by corrosion because the azimuth current was high, and the dish didn't move last time I tried to move the dish in azimuth. Elevation works fine. Those motors are up above any water ingress. Cutting a hole to facilitate better draining of water is also possible but has to be re-fiberglass gel coated.

The dish comes apart in 22 mostly very light pieces for the dish surface. But the hinge and elevation axis is a two or three person lift. Below that the azimuth hexagon contains the motor (and resolvers which are likely bad). I don't have any info on them anyway. So really, I do need to do a tear down to be sure rust and corrosion isn't damaging things. The dish also has a limited azimuth angle of +/-60° around due south which was adequate for geostationary satellites. If that can be expanded safely it would greatly help in tracking eventually. The whole dish is made to be a quick deploy military dish. In theory, a trained squad of soldiers can unpack the dish from its built in hexagon crates and have it on the air in twenty minutes, supposedly. It takes me a few hours to take it down or put it up with help for the one heavy lift.



I use Jim Sky's RadioEyes program to calculate the galactic coordinates and real time Right Ascension values for my notes. I code that into the file names of the screen captures of various parts of the SDR# RTL-SDR screen and enter it into my observing notes.

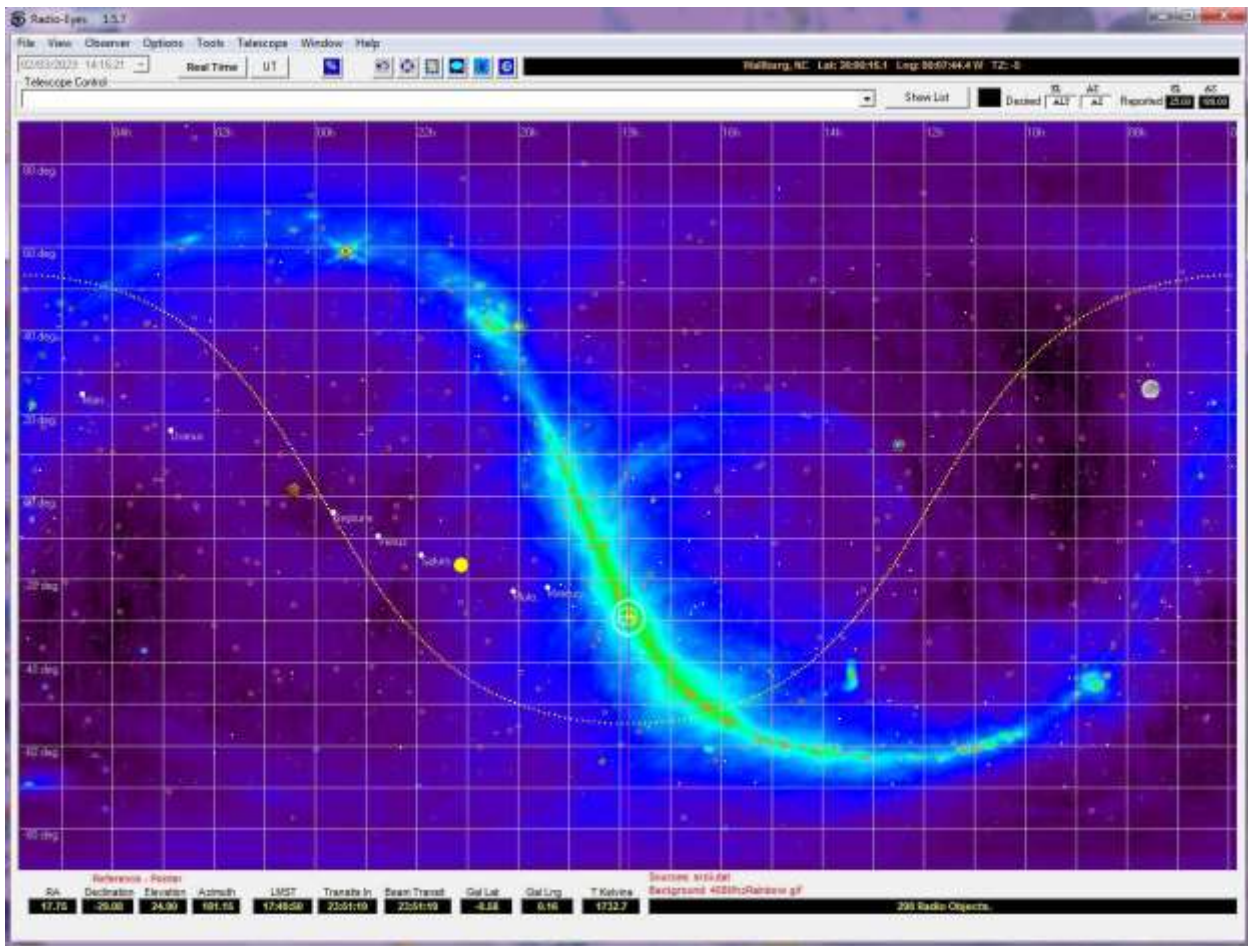

Stellarium in Telerad Viewfinder 8° mode gives me a pretty good close up of what portion of the sky might be influencing my observation at any given time. It's also very useful in predicting Sun transits and real time info on the Sun's position relative to the antenna beam. Using the observation at the predicted elevation angle for the Sun vs real time position data you can quickly evaluate if the dish is pointed due south or not. If the Sun peaks early you are actually pointed East of due south. Stellarium will help you decide how much off it is. Of course if the feed is not positioned correctly that can skew the symmetry of the antenna pattern and cause similar errors. A lot can be inferred from the symmetry of the Sun scan.

One other factor to watch out for is compression. If the overall system gain is high enough to saturate or get close to compressing the effect will look a lot like a flattening of the main lobe of the pattern. And the Sun noise will be less than it should be. Plus, the -3dB beamwidth will be artificially wider than it should be. One way I test for compression is by adding a 5 dB attenuator just prior to the RTL SDR. If the LNA is compressing (unlikely except on interference) the attenuator won't improve the situation. Adding attenuation there will hurt overall system noise temperature and sensitivity if the LNA gain isn't high enough to dominate the noise calculations. I normally run a 2 dB attenuator at that point in the system. It's just enough to help smooth out some return loss interactions



between stages. If the system noise temperature is best with only the two dB attenuator that shows things are set optimally.



The feed on the dish is a Mike Melum KL6M 1296 MHz circularly polarized feed which uses a septum polarizer design by OK1DFC. It is designed to have enough isolation to help protect the receive LNA on the SMA connector on left side from being damaged by the transmit signal fed in on the N connector on the right side. I did not retune it for 1420 MHz. It seemed to have adequate return loss there. So, to preserve the more critical transmit receive isolation I left it tuned for 1296 MHz. The waveguide feed should also provide some interference rejection at lower frequencies like cellphone interference.

The LNA is the a NoElec SAWBird mounted on the feed. 75 feet of RG214 coax feeds the signal indoors to my second floor office and lab. There it receives more filtering and a LaNA amp with bias tees as needed to feed 5vdc out on the coax and power the LaNA. An RTL-SDR and SDR# performs the data averaging and logging.

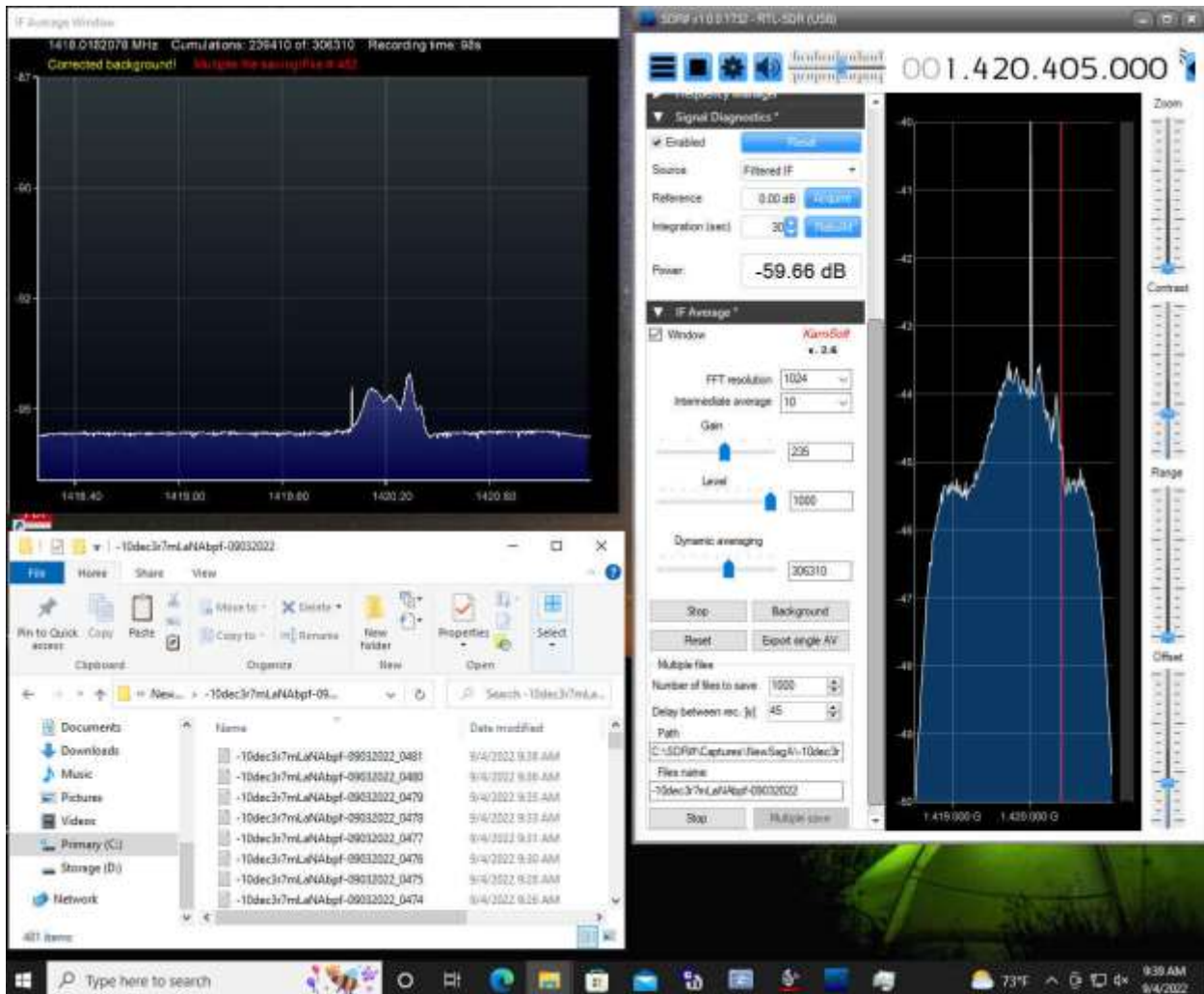

Averaging is set to 306310 measurements resulting in about a 2minute per file record. The 1000 file limit is reached in about 25 hours. I usually restart a run at the same declination for two or three days to make sure I capture good galactic ridge crossings in case there was RFI one day. Remember my dish is fairly large so my two-minute measurement times may be faster than a smaller dish. Mostly I can resolve an interesting amount of detail changing that quickly during the ridge crossings.

One other unusual thing I do is do the background capture on a spot in the sky I call a dead zone. Radio Eyes shows a number of lower emission areas that look black in the outside the Galactic Plane area. It's hard to find anywhere that you have no Hydrogen emissions. But just watch the RTL-SDR screen for a minimal emission spot. This often gives me a good flatline zero for a week at the time. I can even change elevation sometimes without a big penalty in noise changes. The dead zone is around 9 hours right ascension from -10 to +36 declination. The only penalty is an occasional small divot out of the baseline where the residual Hydrogen changes from what was present during the baseline capture.

Plenty of room for improvement, I'm sure. I will likely try Ted Cline's ezRA as soon as I figure it out, as one of my next learning experiences. Other projects like tracking or adding a noise source for Calibration will no doubt keep me busy for years more. ---the end---

## Sudden Frequency Deviations Observed at Anchorage, Alaska

Whitham D. Reeve

The radiation from a solar flare enhances the ionization in Earth's upper atmosphere and can disturb radio propagation over a wide frequency range. A disturbance known as a Sudden Frequency Deviation (SFD) can occur in the HF band. From {Reeve15}: *Two ionospheric conditions are attributed to sudden frequency deviations, both caused by the x-ray, extreme ultraviolet and ultraviolet energy released by a solar flare. First, a slab of ionosphere below the reflection region undergoes a rapid change in refraction index and, second, the ionosphere's reflection region undergoes a rapid vertical movement. Both conditions introduce a Doppler shift in the radio wave by changing the effective path length. Either one or both together can cause a sudden frequency deviation.*

The waterfall images showing SFDs in figures 1 and 2 were produced on 10 and 11 January 2023, respectively, at Anchorage Radio Observatory with three receivers and an HF log periodic dipole array antenna. The receivers were set to the lower sideband (LSB) mode and tuned nominally 1 kHz above the carrier frequencies 15 and 20 MHz (stations WWV and WWVH) and 25 MHz (station WWV only). The demodulated audio from each receiver was fed through an analog audio mixer to the audio Line In jack on a PC where it was processed and plotted by the Argo software as a narrowband (40 Hz) horizontal waterfall. Multiple Argo images have been spliced and cropped.

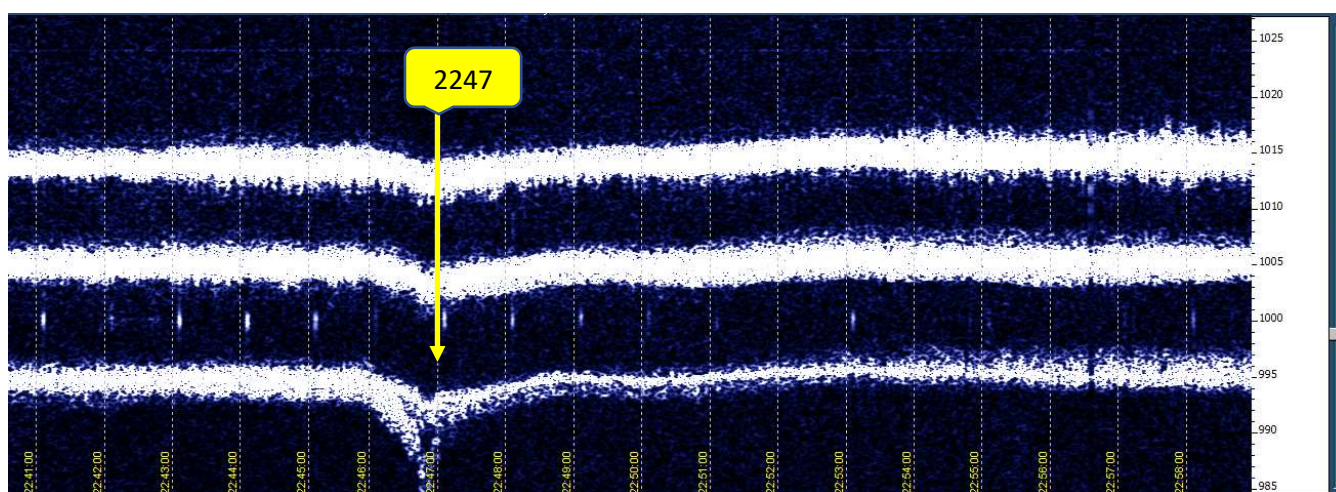

Figure 1 ~ Argo plot for 2241 to 2259 on 10 January 2023 UTC showing an SFD starting at 2246. The yellow time hack is placed near the SFD peak of about  $-10$  Hz frequency deviation at 15 MHz. The SFD is most pronounced at 15 MHz and almost nonexistent at 25 MHz. The propagating carrier encountered additional absorption for several minutes afterwards at 15 MHz by the added ionization in the ionosphere's D-region. The SFD was caused by an impulsive X1.0 flare at solar Active Region 3186 beginning at 2239, peaking at 2247 and ending at 2252.

Timestamps (HH:MM:SS) in the Argo plots are shown at 1 min intervals along the bottom horizontal scale and the demodulated frequency (Hz) is shown on the right vertical frequency scale. The white traces are the demodulated carriers. The lower trace at 995 Hz in both figures is from a receiver tuned to 15.000 995 MHz, the middle trace at 1005 Hz is from a receiver tuned to 20.001 005 MHz, and the upper trace at 1015 Hz is from a receiver tuned to 25.001 015 MHz, all in LSB mode.

The WWV transmitters are about 3800 km east of Anchorage and the WWVH transmitters are about 4400 km south of Anchorage (figure 3). The event shown in figure 1 occurred about 3 h before local sunset and the event in figure 2 occurred about 40 minutes after local sunset. The earlier event could have involved both WWV and WWVH (both paths were illuminated by the Sun), but the later event probably involved only WWVH in Hawaii (the WWV path was in darkness). The actual stations being received were not recorded.

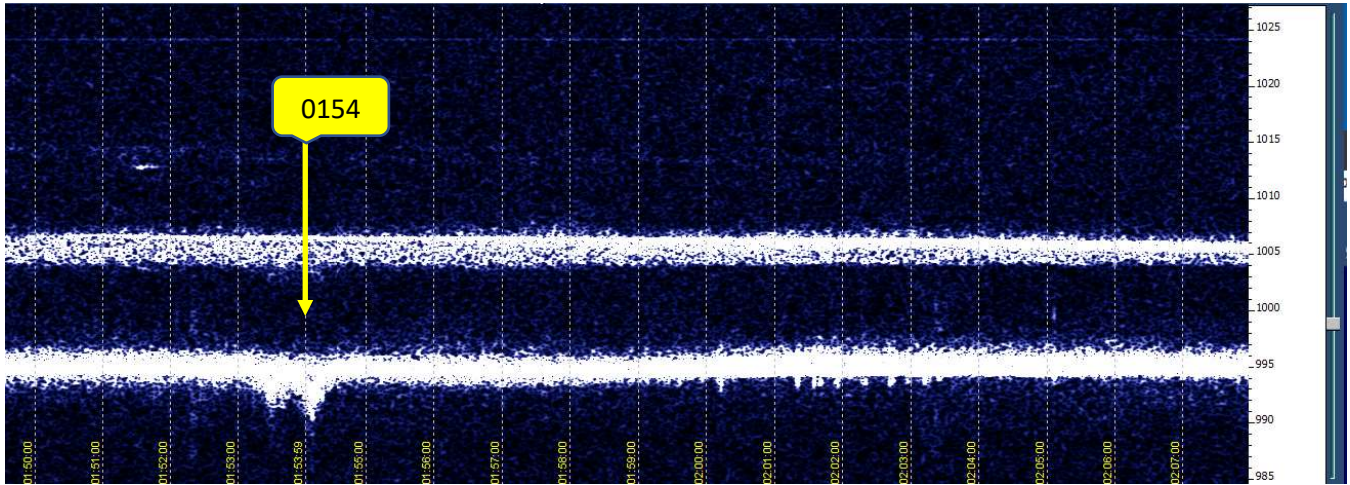

Figure 2 ~ Argo plot for 0150 to 0208 on 11 January 2023 UTC showing a weak double-peak SFD at 15 MHz (lower trace). The deviation was only a few Hz. The yellow time hack is placed near the SFD peak. There was no discernible effect on 20 MHz propagation (middle trace). The propagation at 25 MHz was variable between the event shown in the previous figure and this event but was completely blacked out about 20 minutes before this event. The SFD was caused by an M5.6 flare at solar Active Region 3186 beginning at 0149, peaking at 0156 and ending at 0201. This is the same region as in figure 1.

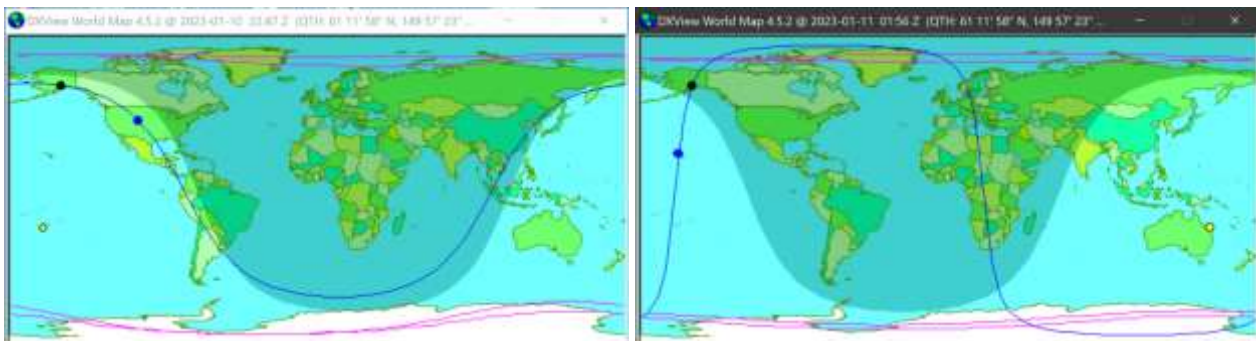

Figure 3 ~ Great circle propagation paths (blue lines), solar terminator (edge of gray area) and stations (blue dots). **Left:** WWV and Anchorage Radio Observatory path with the solar terminator shown at 2247 UTC on 10 January. **Right:** WWVH and Anchorage Radio Observatory path with the solar terminator shown at 0156 UTC on 11 January. Images from DXView.

The overall solar activity during 10 and 11 January was very high with many other flares and radio bursts and radio sweeps, but the only sudden frequency deviations observed at Anchorage were as described above.

**References:**

{Reeve15} Reeve, W., Sudden Frequency Deviations Caused by Solar Flares, Part I ~ Concepts, available at: [https://reeve.com/Documents/Articles%20Papers/Propagation%20Anomalies/Reeve\\_SuddenFreqDevConcepts\\_P1.pdf](https://reeve.com/Documents/Articles%20Papers/Propagation%20Anomalies/Reeve_SuddenFreqDevConcepts_P1.pdf)

## Journal Archives and Other Promotions

The rich and diverse legacy of member contributed content is available in the SARA Journal Archives. Table of contents for journals is available online at [radio-astronomy.org/store](http://radio-astronomy.org/store).

The entire set of The Journal of The Society of Amateur Radio Astronomers is available on USB drive. It goes from the beginning of 1981 to the end of 2022 (over 6000 pages of SARA history!) Or you can choose one of the following USB drive's or DVD:\* (Prices are US dollars and include postage.)

All SARA journals and conference proceedings are available through the previous calendar year.

Prices, US dollars, including postage

### Members

Each USB drive	\$15.00
USB drive + 1-year membership extension	\$30.00

### Non-members

Each USB drive	\$25.00
USB drive + 1-year membership	\$30.00

### Non-USA members

Each USB drive	\$20.00 (airmail)
USB drive+ 1-year members extension	\$35.00

\*Already a member and want any or all these USB drives or DVD's? Buy any one for \$15.00 or get any three for \$35.00.

SARA Store ([radio-astronomy.org/store](http://radio-astronomy.org/store).)

SARA offers the above USB drives, DVDs, printed Proceedings and Proceedings on USB drive and other items at the SARA Store: <http://www.radio-astronomy.org/e-store>. Proceeds from sales go to support the student grant program. Members receive an additional 10% discount on orders over \$50 US. Payments can be made by sending payment by PayPal to [treas@radio-astronomy.org](mailto:treas@radio-astronomy.org) or by mailing a check or money order to SARA, c/o Brian O'Rourke, 337 Meadow Ridge Rd, Troy, VA 22974-3256

### SARA Online Discussion Group

SARA members participate in the online forum at <http://groups.google.com/group/sara-list>. This is an invaluable resource for any amateur radio astronomer.

### SARA Conferences

SARA organizes multiple conferences each year. Participants give talks, share ideas, attend seminars, and get hands-on experience. For more information, visit <http://www.radio-astronomy.org/meetings>.

### Facebook

Like SARA on Facebook

<http://www.facebook.com/pages/Society-of-Amateur-Radio-Astronomers/128085007262843>

### Twitter

Follow SARA on Twitter@RadioAstronomy1

## What is Radio Astronomy?

This link is for a booklet explaining the basics of radio astronomy.

<http://www.radio-astronomy.org/pdf/sara-beginner-booklet.pdf>

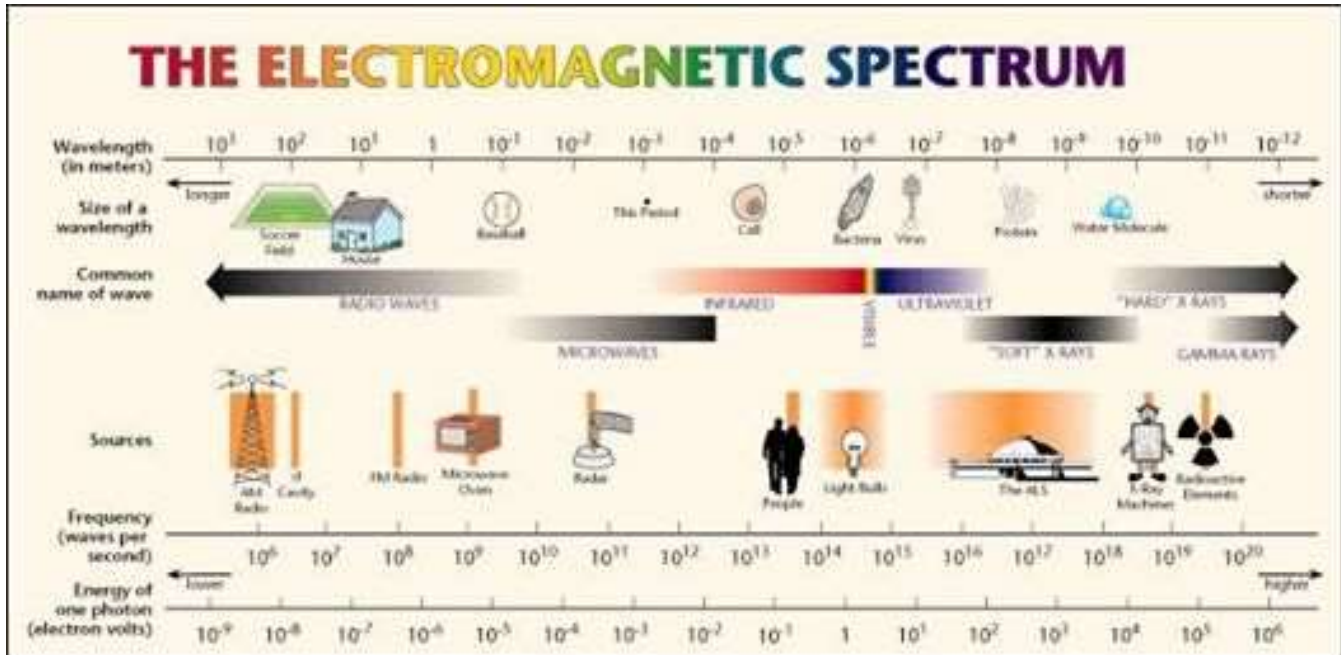

## Administrative

### Officers, directors, and additional SARA contacts

The Society of Amateur Radio Astronomers is an all-volunteer organization. The best way to reach people on this page is by email with SARA in the subject line SARA Officers.

President: Dr. Rich Russel, AC0UB, <https://www.radio-astronomy.org/contact/President>

Vice President: Jay Wilson, <https://www.radio-astronomy.org/contact/Vicepresident>

Secretary: Bruce Randall, NT4RT, <https://www.radio-astronomy.org/contact/Secretary>

Treasurer: Brian O'Rourke, K4UL, <https://www.radio-astronomy.org/contact/Treasurer>

Past President: Dennis Farr

Founder Emeritus and Director: Jeffrey M. Lichtman, KI4GIY, [jeff@radioastronomysupplies.com](mailto:jeff@radioastronomysupplies.com)

### Board of Directors

Name	Term expires	Email
Ed Harfmann	2024	<a href="mailto:edharfmann@comcast.net">edharfmann@comcast.net</a>
Dr. Wolfgang Herrmann	2023	<a href="mailto:messbetrieb@astropeiler.de">messbetrieb@astropeiler.de</a>
Tom Jacobs	2023	<a href="mailto:tdj0@bellsouth.net">tdj0@bellsouth.net</a>
Charles Osborne	2023	<a href="mailto:k4cso@twc.com">k4cso@twc.com</a>
Bob Stricklin	2024	<a href="mailto:bstrick@n5brg.com">bstrick@n5brg.com</a>
Steve Tzikas	2024	<a href="mailto:Tzikas@alum.rpi.edu">Tzikas@alum.rpi.edu</a>
Jon Wallace	2023	<a href="mailto:wallacefj@comcast.net">wallacefj@comcast.net</a>
David Westman	2024	<a href="mailto:david.westman@engineeringretirees.org">david.westman@engineeringretirees.org</a>

### Other SARA Contacts

All Officers	<a href="http://www.radio-astronomy.org/contact-sara">http://www.radio-astronomy.org/contact-sara</a>	
All Directors and Officers	<a href="http://www.radio-astronomy.org/contact/All-Directors-and-Officers">http://www.radio-astronomy.org/contact/All-Directors-and-Officers</a>	
Eastern Conference Coordinator	<a href="http://www.radio-astronomy.org/contact/Annual-Meeting">http://www.radio-astronomy.org/contact/Annual-Meeting</a>	
All Radio Astronomy Editors	<a href="http://www.radio-astronomy.org/contact/Newsletter-Editor">http://www.radio-astronomy.org/contact/Newsletter-Editor</a>	
Radio Astronomy Editor	Dr. Richard A. Russel	<a href="mailto:drrichrussel@netscape.net">drrichrussel@netscape.net</a>
Contributing Editor	Whitham D. Reeve	<a href="mailto:whitreeve@gmail.com">whitreeve@gmail.com</a>
Educational Outreach	<a href="http://www.radio-astronomy.org/contact/Educational-Outreach">http://www.radio-astronomy.org/contact/Educational-Outreach</a>	
Grant Committee	Tom Crowley	<a href="mailto:grants@radio-astronomy.org">grants@radio-astronomy.org</a>
Membership Chair	<a href="http://www.radio-astronomy.org/contact/Membership-Chair">http://www.radio-astronomy.org/contact/Membership-Chair</a>	
Technical Queries (David Westman)	<a href="http://www.radio-astronomy.org/contact/Technical-Queries">http://www.radio-astronomy.org/contact/Technical-Queries</a>	
Webmaster	Ciprian (Chip) Sufitchi, N2YO	<a href="mailto:webmaster@radio-astronomy.org">webmaster@radio-astronomy.org</a>

## Resources

### Great Projects to Get Started in Radio Astronomy

#### Radio Observing Program

The Astronomical League (AL) is starting a radio astronomy observing program. If you observe one category, you get a Bronze certificate. Silver pin is two categories with one being personally built. Gold pin level is at least four categories. (Silver and Gold level require AL membership which many clubs have membership. For the bronze level, you need not be a member of AL.)

Categories include

- 1) SID
- 2) Sun (aka IBT)
- 3) Jupiter (aka Radio Jove)
- 4) Meteor back-scatter
- 5) Galactic radio sources

This program is a collaboration between NRAO and AL. Steve Boerner is the Lead Coordinator and a SARA member.

For more information:

Steve Boerner

2017 Lake Clay Drive

Chesterfield, MO 63017

Email: [sboerner@charter.net](mailto:sboerner@charter.net)

Phone: 636-537-2495

<http://www.astroleague.org/programs/radio-astronomy-observing-program>

#### Radio Jove



The Radio Jove Project monitors the storms of Jupiter, solar activity and the galactic background. The radio telescope can be purchased as a kit, or you can order it assembled. They have a terrific user group you can join. <http://radiojove.gsfc.nasa.gov/>



## INSPIRE Program



The INSPIRE program uses build-it-yourself radio telescope kits to measure and record VLF emissions such as tweeks, whistlers, sferics, and chorus along with man-made emissions. This is a very portable unit that can be easily transported to remote sites for observations.

<http://theinspireproject.org/default.asp?contentID=27>

## SARA/Stanford SuperSID



Stanford Solar Center and the Society of Amateur Radio Astronomers have teamed up to produce and distribute the SuperSID (Sudden Ionospheric Disturbance) monitor. The monitor utilizes a simple pre-amp to magnify the VLF radio signals which are then fed into a high definition sound card. This design allows the user to monitor and record multiple frequencies simultaneously. The unit uses a compact 1-meter loop antenna that can be used indoors or outside. This is an ideal project for the radio astronomer that has limited space. To request a unit, send an e-mail to [supersid@radio-astronomy.org](mailto:supersid@radio-astronomy.org)

## Radio Astronomy Online Resources

SARA YouTube Videos: <a href="https://www.youtube.com/channel/UC-SzptAQZ-20c9CkRb9ZPpw/videos">https://www.youtube.com/channel/UC-SzptAQZ-20c9CkRb9ZPpw/videos</a>	
AJ4CO Observatory – Radio Astronomy Website: <a href="http://www.aj4co.org/">http://www.aj4co.org/</a>	A New Radio Telescope for Mexico - ORION 2021 01 20. Dr. Stan Kurtz <a href="https://www.youtube.com/watch?v=Q9aBWr1aBVc">https://www.youtube.com/watch?v=Q9aBWr1aBVc</a>
Radio Astronomy calculators <a href="https://www.aj4co.org/Calculators/Calculators.html">https://www.aj4co.org/Calculators/Calculators.html</a>	National Radio Astronomy Observatory <a href="http://www.nrao.edu">http://www.nrao.edu</a>
Introduction to Amateur Radio Astronomy (presentation) <a href="http://www.aj4co.org/Publications/Intro%20to%20Amateur%20Radio%20Astronomy,%20Typinski%20(AAC,%202016)%20v2.pdf">http://www.aj4co.org/Publications/Intro%20to%20Amateur%20Radio%20Astronomy,%20Typinski%20(AAC,%202016)%20v2.pdf</a>	NRAO Essential Radio Astronomy Course <a href="http://www.cv.nrao.edu/course/astr534/ERA.shtml">http://www.cv.nrao.edu/course/astr534/ERA.shtml</a>
RF Associates Richard Flagg, rf@hawaii.rr.com 1721-1 Young Street, Honolulu, HI 96826	Exotic Ions and Molecules in Interstellar Space -- ORION 2020 10 21. Dr. Bob Compton <a href="https://www.youtube.com/watch?v=r6cKhp23SUo&amp;t=5s">https://www.youtube.com/watch?v=r6cKhp23SUo&amp;t=5s</a>
RFSpace, Inc. <a href="http://www.rfspace.com">http://www.rfspace.com</a>	The Radio JOVE Project & NASA Citizen Science – ORION 2020.6.17. Dr. Chuck Higgins <a href="https://www.youtube.com/watch?v=s6eWAXjywp8&amp;t=5s">https://www.youtube.com/watch?v=s6eWAXjywp8&amp;t=5s</a>
CALLISTO Receiver & e-CALLISTO <a href="http://www.reeve.com/Solar/e-CALLISTO/e-callisto.htm">http://www.reeve.com/Solar/e-CALLISTO/e-callisto.htm</a>	UK Radio Astronomy Association <a href="http://www.ukraa.com/">http://www.ukraa.com/</a>
Deep Space Exploration Society <a href="http://DSES.science">http://DSES.science</a>	CALLISTO software and data archive: <a href="http://www.e-callisto.org">www.e-callisto.org</a>
Deep Space Object Astrophotography Part 1 -- ORION 2021 02 17. George Sradnov <a href="https://www.youtube.com/watch?v=Pm_Rs17KlyQ">https://www.youtube.com/watch?v=Pm_Rs17KlyQ</a>	Radio Jove Spectrograph Users Group <a href="http://www.radiojove.org/SUG/">http://www.radiojove.org/SUG/</a>
European Radio Astronomy Club <a href="http://www.eraonet.org">http://www.eraonet.org</a>	Radio Sky Publishing <a href="http://radiosky.com">http://radiosky.com</a>
British Astronomical Association – Radio Astronomy Group <a href="http://www.britastro.org/baa/">http://www.britastro.org/baa/</a>	The Arecibo Radio Telescope; It's History, Collapse, and Future - ORION 2020.12.16. Dr. Stan Kurtz, Dr. David Fields <a href="https://www.youtube.com/watch?v=rBZIPOLNX9E">https://www.youtube.com/watch?v=rBZIPOLNX9E</a>
Forum and Discussion Group <a href="http://groups.google.com/group/sara-list">http://groups.google.com/group/sara-list</a>	Shirleys Bay Radio Astronomy Consortium <a href="mailto:marcus@propulsionpolymers.com">marcus@propulsionpolymers.com</a>
GNU Radio <a href="https://www.gnuradio.org/">https://www.gnuradio.org/</a>	SARA Twitter feed <a href="https://twitter.com/RadioAstronomy1">https://twitter.com/RadioAstronomy1</a>
SETI League <a href="http://www.setileague.org">http://www.setileague.org</a>	SARA Web Site <a href="http://radio-astronomy.org">http://radio-astronomy.org</a>
NRAO Essential Radio Astronomy Course <a href="http://www.cv.nrao.edu/course/astr534/ERA.shtml">http://www.cv.nrao.edu/course/astr534/ERA.shtml</a>	SARA Facebook page <a href="https://www.facebook.com/pages/Society-of-Amateur-Radio-Astronomers/128085007262843">https://www.facebook.com/pages/Society-of-Amateur-Radio-Astronomers/128085007262843</a>
NASA Radio JOVE Project <a href="http://radiojove.gsfc.nasa.gov">http://radiojove.gsfc.nasa.gov</a> Archive: <a href="http://radiojove.org/archive.html">http://radiojove.org/archive.html</a> <a href="https://groups.io/g/radio-jove">https://groups.io/g/radio-jove</a>	Simple Aurora Monitor: Magnetometer <a href="http://www.reeve.com/SAMDescription.htm">http://www.reeve.com/SAMDescription.htm</a>
National Radio Astronomy Observatory <a href="http://www.nrao.edu">http://www.nrao.edu</a>	Stanford Solar Center <a href="http://solar-center.stanford.edu/SID/">http://solar-center.stanford.edu/SID/</a>

## For Sale, Trade and Wanted

At the SARA online store: [radio-astronomy.org/store](http://radio-astronomy.org/store).

### SARA Polo Shirts

New SARA shirts have arrived.

We now have a good selection of X, XX, and XXX shirts available in all colors including white! Shirts are \$20 at the conference and \$25 shipped.

Contact the treasurer at [treas@radio-astronomy.org](mailto:treas@radio-astronomy.org) for availability and shipping.



### Scope in a Box

[radio-astronomy.org/store](http://radio-astronomy.org/store).

Kit of parts and software to build a working Radio Telescope to detect Hydrogen Line emissions. Available to USA addresses only at this time.

**SuperSID Complete Kit (\$112-\$160 depending on options)**

[radio-astronomy.org/store](http://radio-astronomy.org/store).



**SARA Publication, Journals and Conference Proceedings (various prices)**

[radio-astronomy.org/store](http://radio-astronomy.org/store).

**SARA Journal USB Drive (\$15-\$35 depending on shipping option)**

[radio-astronomy.org/store](http://radio-astronomy.org/store).

The USB drive covers the society journal "Radio Astronomy" from the founding of the organization in 1981 thru 2020. Articles cover a wide range of topics including: cosmic radiation, pulsars, quasars, meteor detection, solar observing, Jupiter, Radio Jove, gamma ray bursts, the Itty Bitty Telescope (IBT), dark matter, black holes, the Jansky antenna, methanol masers, mapping at 408 MHz and more. This CD contains all of the above and more with over 4800 pages of articles on radio astronomy. Also included is a copy of Grote Reber's handwritten, 34 page document "Carriage and Mirror Detail" of his historic antenna now on display at the National Radio Astronomy Observatory (NRAO) in Greenbank, WV. You also get an electronic copy of the 109 page "Basics of Radio Astronomy" from JPL Goldstone-Apple Valley Radio Telescope. Also included is the NRAO 40-foot radio telescope "Operators Manual", which by the way, you get to operate if you attend the Eastern SARA conference in July.

## SARA Advertisements

There is no charge to place an ad in Radio Astronomy; but you must be a current SARA member. Ads must be pertinent to radio astronomy and are subject to the editor's approval and alteration for brevity. Please send your "For Sale," "Trade," or "Wanted" ads to [edit@radio-astronomy.org](mailto:edit@radio-astronomy.org). Please include email and/or telephone contact information. Please keep your ad text to a reasonable length. Ads run for one bimonthly issue unless you request otherwise.

### **Radio-Astro-Machine, [zblac@gmail.com](mailto:zblac@gmail.com)**

Elevation rotation adapter plate for Scope in a Box and custom machining. For further information visit <https://radio-astro-machine.wixsite.com/my-site> or send an email.

### **Typinski Radio Astronomy, Inc., [info@typinski.com](mailto:info@typinski.com)**

Antenna systems and feed line components for HF radio astronomy

### **Jeff Kruth, WA3ZKR, [kmec@aol.com](mailto:kmec@aol.com)**

RF components from HF to MMW, various types including mixers, RF switches, amplifiers, oscillators, coaxial components, waveguide components, etc. I have a very large collection of stuff and the facilities to test and provide data. Please email with your needs and I will see if I have something for you. Have fun!

### **Stuart and Lorraine Rumley, [sales@valontechnology.com](mailto:sales@valontechnology.com)**

The Valon Technology 2100 Downconverter, when combined with our 5009 frequency synthesizer module, provides a high-performance, compact receiver downconverter system. Applications include hydrogen line studies at 1420MHz and radio astronomy in the protected 30MHz segment of the 21 cm band. For more information visit <http://www.valontechnology.com/2100downconverter.html> or send an email.

### **Radio2Space, [filippo.bradaschia@primalucelab.com](mailto:filippo.bradaschia@primalucelab.com)**

SPIDER radio telescopes and turn-key-systems designed specifically for education.

<https://www.radio2space.com>

We developed our SPIDER radio telescopes as turn-key-system just to avoid the problem you perfectly highlighted in your website: "Purchasing a radio telescope isn't like buying an optical telescope. They are harder to find, and usually require assembly and software troubleshooting. In some cases, a radio telescope must be built from components." Our SPIDER radio telescopes are not designed for amateurs that prefer to build a radio telescope but to schools, universities, museums, and other science institutes that needs for a complete and ready-to-use system, just like the optical telescopes they can normally buy!

**Membership Information**

Annual SARA dues Individual \$20, Classroom \$20, Student \$5 (US funds) anywhere in the world. Membership includes a subscription to Radio Astronomy, the bimonthly Journal of The Society of Amateur Radio Astronomers, delivered electronically (via a secure web link, emailed to you as each new issue is posted). We regret that printing and postage costs prevent SARA from providing hardcopy subscriptions to our Journal.

We would appreciate the following information included with your check or money order, made payable to SARA:

Name: \_\_\_\_\_  
 Email Address: \_\_\_\_\_  
(required for electronic Journal delivery)  
 Ham call sign: \_\_\_\_\_ (if applicable)  
 Address: \_\_\_\_\_  
 City: \_\_\_\_\_  
 State: \_\_\_\_\_  
 Zip: \_\_\_\_\_  
 Country: \_\_\_\_\_  
 Phone: \_\_\_\_\_

Please include a note of your interests. Send your application for membership, along with your remittance, to our Treasurer.

For further information, see our website at: <http://radio-astronomy.org/membership>



Membership supported, nonprofit [501(c) (3)]  
 Educational and Radio Astronomy Organization  
**Knowledge through Common Research,  
 Education and Mentoring**

**How to get started?**

SARA has a made a kit of software and parts to detect the Hydrogen line signal from space. This is an excellent method to get started in radio astronomy. It teaches the principles of antenna design, signal detection, and signal processing. Read more about this and other projects on our web site.

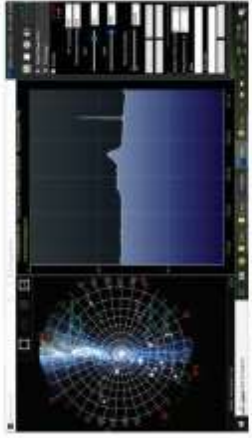

SARA members have been privileged to use this forty foot diameter drift-scan hydrogen line radio telescope every year at their annual meeting in Green Bank.



<http://radio-astronomy.org>

**Why Radio Astronomy?**

Because about sixty five percent of our current knowledge of the universe has stemmed from radio astronomy alone. The discovery of quasars, pulsars, black holes, the 3K background from the "Big Bang" and the discovery of biochemical hydrogen/carbon molecules are all the result of professional radio astronomy.

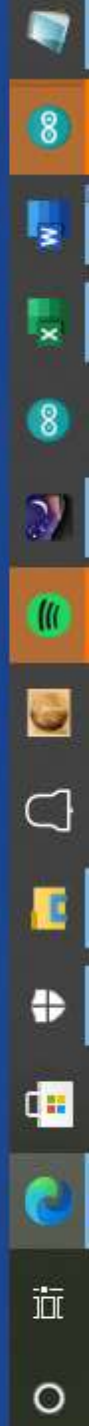

## The Society of Amateur Radio Astronomers

SARA was founded in 1981, with the purpose of educating those interested in pursuing amateur radio astronomy.

The society is open to all, wishing to participate with others, worldwide.

SARA members have many interests, some are as follows:

### SARA Areas of Study and Research:

- Solar Radio Astronomy
- Galactic Radio Astronomy
- Meteor Detection
- Jupiter
- SETI
- Gamma Ray/High Energy Pulse Detection
- Antennas
- Design of Hardware / Software

The members of the society offer a friendly mentor atmosphere. All questions and inquiries are answered in a constructive manner. No question is silly!

SARA offers its members an electronic bi-monthly journal entitled Radio Astronomy. Within the journal, members report on their research and observations. In addition, members receive updates on the professional radio astronomy community and, society news.

Once a year SARA meets for a three-day conference at the Green Bank Observatory in Green Bank West Va.

There is also a spring conference held at various cities in the Western USA. Previous meetings have been at the VLA in Socorro, NM and at Stanford University.



### How do amateurs do radio astronomy?

Radio astronomy by amateurs is conducted using antennas of various shapes and sizes, from smaller parabolic dishes to simple wire antennas. These antennas are connected to receivers and most of these receivers are software defined radios these days. Data from the receivers are collected by computers, and the received signals will be displayed as charts, graphs or maybe even sky maps. As diverse as the observed objects, so is the instruments and tools used. SARA members will always be supportive to find good solutions for what one wishes to observe.

### Is amateur radio astronomy instrumentation expensive?

Technical information freely circulated in our monthly journal helps amateurs to obtain good low noise equipment from off the shelf assemblies, or to build their own units. The actual cash investment in radio astronomy equipment need not exceed that of any other hobby.

### What are amateurs actually looking for in the received data?

The aim of the radio amateur is to find something new and unusual. Just as an amateur optical observer hopes to notice a supernova or a new comet, so does an amateur radio observer hope to notice a new radio source, or one whose radiation has changed appreciably.

### How do I get started?

Just as a long journey begins with the first step, the project you elect must start with a clear idea of your objectives. Do you wish to study the sun? Jupiter? Make meteor counts? Do you wish to engage in imaging radio astronomy? What you decide will not only determine the type of equipment you will need, but also the local radio spectrum.



The Reber Telescope at NRAO. Constructed by Grote Reber in 1937 in his back yard in Wheaton, Illinois



SARA Members discussing the IBT (Itty Bitty Telescope)

