

RADIO ASTRONOMY

Journal of the Society of Amateur Radio Astronomers
Jan-Feb 2021

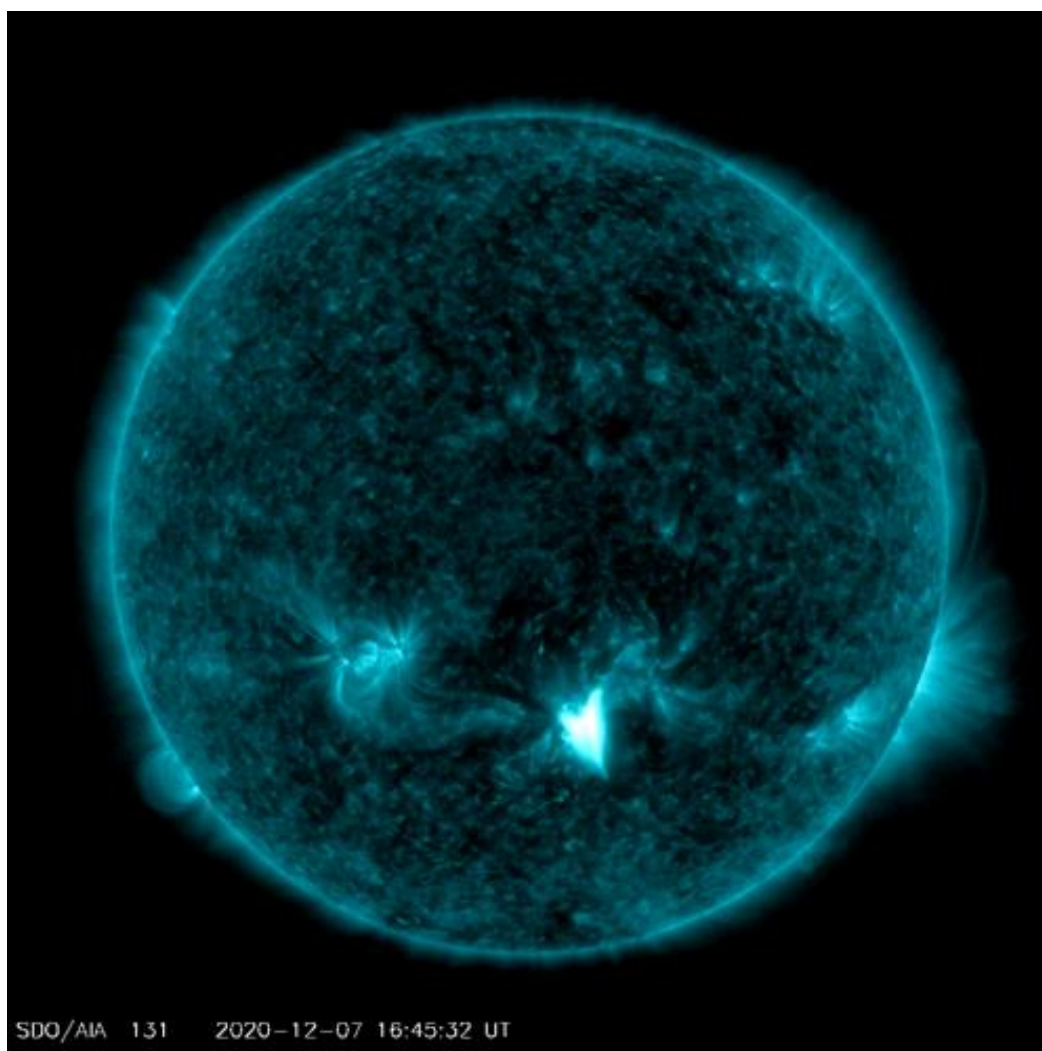

SDO/AIA 131 2020-12-07 16:45:32 UT



Dennis Farr
SARA President

Bogdan Vacaliuc
Richard A. Russel
Editors

Steve Black
Whitham D. Reeve
Michael Stewart
Contributing Editors

Radio Astronomy is published bimonthly as the official journal of the Society of Amateur Radio Astronomers. Duplication of uncopyrighted material for educational purposes is permitted but credit shall be given to SARA and to the specific author. Copyrighted materials may not be copied without written permission from the copyright owner.

Radio Astronomy is available for download only by SARA members from the SARA web site and may not be posted anywhere else.

It is the mission of the Society of Amateur Radio Astronomers (SARA) to: Facilitate the flow of information pertinent to the field of Radio Astronomy among our members; Promote members to mentor newcomers to our hobby and share the excitement of radio astronomy with other interested persons and organizations; Promote individual and multi station observing programs; Encourage programs that enhance the technical abilities of our members to monitor cosmic radio signals, as well as to share and analyze such signals; Encourage educational programs within SARA and educational outreach initiatives. Founded in 1981, the Society of Amateur Radio Astronomers, Inc. is a membership supported, non-profit [501(c) (3)], educational and scientific corporation. Copyright © 2019 by the Society of Amateur Radio Astronomers, Inc. All rights reserved.

Cover: Solar CME NASA

Contents

Radio Waves	3
President's Page.....	3
Editor's Notes	4
News	5
Virtual 2021 SARA Spring Conference to be held on April 3, 2021	7
Virtual Meetings Announcement	10
IERS Leap Second Notice	14
Technical Knowledge and Education	15
For Your Radio Astronomy Bookshelf	18
Book Review	19
The British Astronomical Association Solar Report.....	20
70 th Anniversary of the Discovery of Radio Emissions from Neutral Hydrogen..	30
SuperSID	33
Feature Articles	36
Impedance Matching Issue with the CALLISTO Solar Radio Spectrometer.....	36
Getting the Best out of the PRESTO Pulsar Search & Analysis Tools	40
Sample of HF Meteor Trail Reflections Observed at Anchorage, Alaska USA.....	49
Using a MAX 2870/71 Signal Source Generator as a Pulsar Simulator	51
Reference Frequency Distribution System.....	55
Membership	63
New Members.....	63
Journal Archives & Other CDs Promotion	64
SARA Online Discussion Group.....	64
What is Radio Astronomy?.....	65
Administrative	66
Officers, directors, and additional SARA contacts.....	66
Resources	67
Great Projects to Get Started in Radio Astronomy	67
Online Resources.....	69
For Sale, Trade and Wanted	70

Radio Waves

President's Page

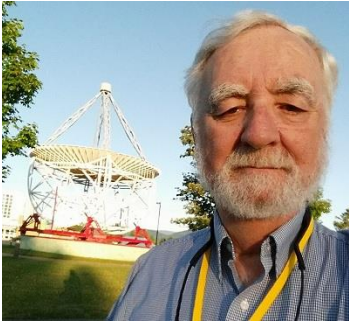

Moving forward with the society's business, we have a new treasurer. Brian O'Rourke has stepped up to the task and has been installed as the new treasurer. Thank you, Brian.

The scope in a box program is fully implemented. All we need now are orders. Remember, the kit could be made available as a grant to worthy programs. If you know of a group that might qualify, please have them contact us at grants@radio-astronomy.org

Steve Tzikas is doing a great job doing outreach by writing articles for the Reflector, the official publication of the Astronomical League. If you haven't joined the AL, you should consider it. They have observing programs, including Radio Astronomy, that are very useful for learning more about astronomy. SARA has a goal of providing all the hardware kits necessary for pursuing the radio astronomy program. They will include SuperSID, Scope in a box, and IBT.

The Drakes lounge monthly ZOOM meetings are extremely interesting and cover topics in an informal manner. Typically, we are getting about 20 people attend. Always room for more. You should be receiving an email each month with the schedule and link to the meeting. The meetings are held the 3rd Sunday of each month starting at 1400 ET.

We have redone the membership brochure that is used as a handout at meetings and conventions such as Hamvention. The new brochure can be seen at <https://www.radio-astronomy.org/pdf/brochure.pdf> or, click on the link on the membership page. If anyone has any of the old brochures, please throw them away. They had names and addresses on them that have changed.

Spring Western virtual ZOOM conference is coming up April 3. Please register ASAP if you have not already done so. Complete details in this issue of the Journal, or on our web site.

We have high hopes that we will be able to hold our annual conference at Green Bank on August 1-3. Covid shows signs of slowing down and hopefully GBO will be once again hosting events. Regardless of an onsite live conference, there will be a virtual ZOOM conference as well.

Keep your antennas pointed up!

Dennis

Editor's Notes

We are always looking for basic radio astronomy articles, radio astronomy tutorials, theoretical articles, application and construction articles, news pertinent to radio astronomy, profiles and interviews with amateur and professional radio astronomers, book reviews, puzzles (including word challenges, riddles, and crossword puzzles), anecdotes, expository on "bad astronomy," articles on radio astronomy observations, suggestions for reprint of articles from past journals, book reviews and other publications, and announcements of radio astronomy star parties, meetings, and outreach activities.

If you would like to write an article for Radio Astronomy, please follow **the newly-updated Author's Guide** on the SARA web site: http://www.radio-astronomy.org/publicat/RA-JSARA_Author's_Guide.pdf.

Let us know if you have questions; we are glad to assist authors with their articles and papers and will not hesitate to work with you. You may contact your editors any time via email here: edit@radio-astronomy.org.

The editor(s) will acknowledge that they have received your submission within two days. If they do not reply, assume they didn't receive it and please try again.

Please consider submitting your radio astronomy observations for publication: any object, any wavelength. Strip charts, spectrograms, magnetograms, meteor scatter records, space radar records, photographs; examples of radio frequency interference (RFI) are also welcome.
Guidelines for submitting observations may be found here: http://www.radio-astronomy.org/publicat/RA-JSARA_Observation_Submission_Guide.pdf

Tentative *Radio Astronomy* due dates and distribution schedule

Issue	Articles	Radio Waves	Review	Distribution
Mar – Apr	April 12	April 20	April 25	April 30
May – Jun	June 12	June 20	June 25	June 30
Jul – Aug	August 12	August 20	August 25	August 31
Sep – Oct	October 12	October 20	October 25	October 31
Nov – Dec	December 12	December 15	December 20	December 31

News

Hey, Mac, there you go again, rewriting history: Quanta magazine ~ *The New History of the Milky Way*: <https://www.quantamagazine.org/the-new-history-of-the-milky-way-20201215/>

Phys.org ~ *China to open giant telescope to international scientists*: <https://phys.org/news/2020-12-china-giant-telescope-international-scientists.html>

Phys.org ~ *Giant pulses detected in the pulsar PSR J1047-6709*: <https://phys.org/news/2020-12-giant-pulses-pulsar-psr-j10476709.html>

Phys.org ~ *Astronomers detect possible radio emission from exoplanet*: <https://phys.org/news/2020-12-astronomers-radio-emission-exoplanet.html>

Hey, Mac, let's forget dark matter and go with MOND: Phys.org ~ *Looking for dark matter near neutron stars with radio telescopes*: <https://phys.org/news/2020-12-dark-neutron-stars-radio-telescopes.html>

Phys.org ~ *Why radio astronomers need things quiet in the middle of a Western Australia desert*: <https://phys.org/news/2020-12-radio-astronomers-quiet-middle-western.html>

Hey, Mac, I've said this before and I'll say it again, Wow!: My Modern Met ~ *Scientists Are Investigating a Potential "Alien" Radio Beam From a Nearby Star*: <https://mymodernmet.com/mysterious-beam-proxima-centauri/>

ScienceNews ~ *New fleets of private satellites are clogging the night sky*: <https://www.sciencenews.org/article/starlink-spacex-satellites-amazon-oneweb-global-internet-astronomy>

Phys.org ~ *Periodic and phase-locked modulation in the pulsar PSR B1929+10 investigated with FAST*: <https://phys.org/news/2020-12-periodic-phase-locked-modulation-pulsar-psr.html>

Universe Today ~ *All The Gravitational Waves Detected So Far*: <https://www.universetoday.com/149863/all-the-gravitational-waves-detected-so-far/>

Forbes ~ *Ask Ethan: How Does The CMB Reveal The Hubble Constant?*: <https://www.forbes.com/sites/startswithabang/2021/01/15/ask-ethan-how-does-the-cmb-reveal-the-hubble-constant/>

Phys.org ~ *NASA's deep space network welcomes a new dish to the family*: <https://phys.org/news/2021-01-nasa-deep-space-network-dish.html>

National Radio Astronomy Observatory ~ *Successful Test Paves Way for New Planetary Radar*: <https://public.nrao.edu/news/successful-test-new-planetary-radar/>

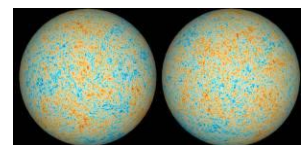
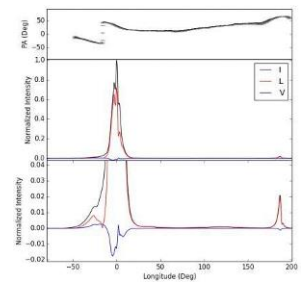
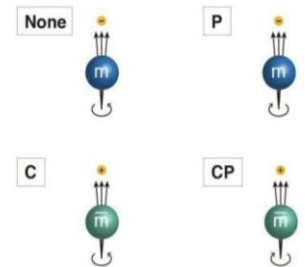
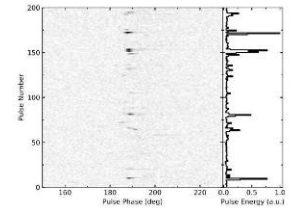
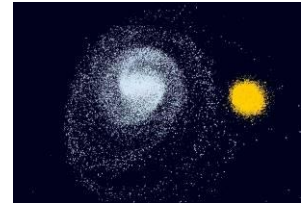

Phys.org ~ *The Very Large Array: Astronomical shapeshifter:*
<https://phys.org/news/2021-01-large-array-astronomical-shapeshifter.html>

Space.com ~ *Preliminary investigation offers possible cause of Arecibo Observatory telescope collapse:* <https://www.space.com/arecibo-telescope-debris-clearing-possible-cause-update>

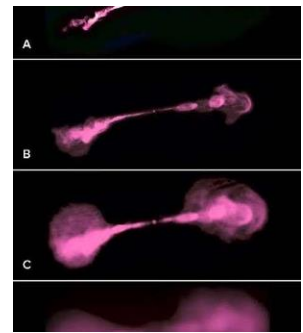

Virtual 2021 SARA Spring Conference to be held on April 3, 2021

The 2021 SARA Spring Conference will be held on Zoom, April 3, 2021. This virtual conference will replace the annual SARA Western Conference because of the continuing COVID-19 pandemic.

Contact: Please contact conference coordinator Dave Westman if you have any questions about the conference or if you would like to help: westernconf_at_radioastronomy_dot_org. Website: www.radio-astronomy.org

Presentations and proceedings: Papers and presentations on radio astronomy hardware, software, education, research strategies, philosophy, and observing efforts and methods are welcome. The deadline for submitting a letter of intent to the conference coordinator including a proposed title and informal abstract or outline is 1 February 2021. Formal proceedings will be published electronically for this conference, and a link will be emailed to registered participants.

Registration: Registration for the 2021 Spring Conference is just US\$25.00. Attendees at the conference must be SARA members; if you are not yet a member, this will cost an additional \$20. Payment can be made by going to www.paypal.com and directing payment to treas_at_radio-astronomy_dot_org. Please include in comments that the payment is for the 2021 Spring Conference. You also can mail a check to SARA Treasurer, 10760 Central Park, New Port Richey, FL 34655. Please include an e-mail address so a confirmation can be sent to you upon receipt of payment.

Call for papers: 2021 SARA Spring Conference

The Society of Amateur Radio Astronomers (SARA) hereby solicits papers for presentation at its 2021 Spring Conference, to be held April 3, 2021 via Zoom. Papers on radio astronomy hardware, software, education, research strategies, observations and philosophy are welcome. SARA members or supporters wishing to present a paper should email a letter of intent, including a proposed title and informal abstract or outline to westernconf_at_radio-astronomy_dot_org no later than 1 February 2021 (please let us know if you require more time). Be sure to include your full name, affiliation, postal address, and email address, and indicate your willingness to participate in the conference to present your paper. Submitters will receive an email response, typically within one week. Formal printed Proceedings will be published electronically for this conference and a link will be sent to each participant prior to the conference. Website: www.radio-astronomy.org

Dr. Miguel Morales
will be the
Keynote Speaker
at the
SARA 2021 Spring Conference



The SARA Conference Coordinator, Dave Westman, is pleased to announce that Dr. Miguel Morales, professor of physics and radio astronomy at the University of Washington in Seattle, WA, has agreed to give the keynote speech at the 2021 SARA Spring Conference on April 3, 2021. Dr. Morales is the leader of the Radio Cosmology Group at the UW and has been the chief scientist for the Murchison Widefield Array (MWA) in Australia. He is also the imaging power spectrum lead for the Hydrogen Epoch of Reionization Array (HERA) in the Karoo desert of South Africa and the director of the UW Dark Universe Science Center (DUSC). He will also be available for questions and conversation during the conference.

SARA 2021 Spring Conference

April 3, 2021, Virtual

Conference Schedule

Time (PST) [UTC]	Activity/Title	Presenter
Saturday, April 3rd		
9:00 – 9:15 [16:00]	Introductions, etc.	Dennis Farr, David Westman
9:15 – 10:00 [16:15]	Keynote Speech	Miguel Morales
10:00 – 10:45 [17:00]	Converting a G5500 AZ/EL Rotor to an RA/DEC Tracking System	Richard Russel
10:45 – 11:00 [17:45]	Break	
11:00 – 12:00 [18:00]	Pulsar Observations at the Astropheiler Stockert Observatory	Wolfgang Hermann
12:00 – 1:00 [19:00]	Lunch Break	
1:00 – 1:45 [20:00]	High-Frequency Active Auroral Research Program: HAARP – 2020	Whitham Reeve
1:45 – 2:30 [20:45]	Implementation, modification, improvements and uses for SARA's Scope in a box	Pablo Lewin
2:30 – 2:45 [21:30]	Break	
2:45 – 3:30 [21:45]	Innovations in merging optical astronomy with radio astronomy	Thomas Ashcraft
3:30 – 4:15 [22:30]	Mendoza SuperSID	David Westman
4:30 [23:30]	Closing Remarks	David Westman

Virtual Meetings Announcement

Heliophysics 2050 Workshop, 2nd Community Announcement

From: Sabrina Savage (sabrina.savage at nasa.gov)

The Heliophysics 2050 Workshop Science Organizing Committee would like to update the community on the upcoming meeting to be held virtually May 3-7, 2021. Due to the broad community response to the call for white papers, two extra days have been added to the workshop from the first announcement.

Details regarding registration and abstract submissions will be forthcoming. Information about the workshop is and will be posted at: <https://www.hou.usra.edu/meetings/helio2050/>.

Sessions will be organized around scene-setting material followed by panel / community discussions. For each session, the SOC will release a summary of the planned scope so that the community can prepare the details of a long-term science strategy. Topics will include the following:

- ⚙ Solar interior, dynamo, and global surface properties
- ⚙ Solar corona and inner heliosphere
- ⚙ Magnetosphere
- ⚙ Ionosphere-Thermosphere-Mesosphere
- ⚙ Space weather (Basic & Applied Research, Operations, & Human Exploration)
- ⚙ Outer heliosphere & local interstellar medium
- ⚙ Expanding the Frontiers of Heliophysics (Planetary magnetospheres/Habitability/Exoplanets/the Sun-as-a-Star)
- ⚙ Fundamental Physical Processes (Turbulence/Plasma-neutral interactions/Magnetic reconnection/Wave-particle interactions/Shocks)
- ⚙ Heliophysics as a Community in 2050

We greatly look forward to your participation in the workshop as we aim to strategically contribute to the Decadal Survey process.

SOC: Shasha Zou, Sabrina Savage, Amir Caspi, Li-jen Chen, Ian Cohen, Larry Kepko, Mark Linton, No? Lugaz, Merav Opher, Larry Paxton, Jaye Verneiro

The Van Allen Probes Mission: Scientific Legacy, Space Weather, and What's to Follow

From: Sasha Ukhorskiy (ukhorskiy at jhaupl.edu)

After a remarkable journey through Earth's ring current and radiation belts the Van Allen Probes mission is coming to its finale; the Phase F of the mission is scheduled to conclude in 2021. To celebrate the tremendous science legacy of the mission, its contribution to Space Weather research, and to discuss the future of the inner magnetosphere exploration we will be holding an international virtual workshop on 5-6 May 2021. Please stay tuned for program announcements.

Whole Heliosphere and Planetary Interactions First Workshop rescheduled 13 - 17 September, 2021

From: Sarah Gibson (sgibson at ucar.edu)

Whole Heliosphere and Planetary Interactions (WHPI) is an international initiative focused around the solar minimum period that aims to understand the interconnected sun-heliospheric-planetary system. The WHPI hands-on workshop has been rescheduled to occur September 13-17, 2021. It will be primarily a virtual workshop, with possible small-scale in-person gatherings. We do not expect there to be a registration fee. The goal of the workshop will be to foster collaborations across disciplines by providing a forum for comparing models and observations of specific aspects of the extended solar minimum time period in a truly interactive and collaborative environment. In particular, we encourage participants to contribute and share observations, model products, and analysis tools. Information will be provided on a repository for these data in advance of the workshop.

More information can be found at: <https://cpaess.ucar.edu/meetings/2021/whole-heliosphere-planetary-interactions> . Please pre-register here: <https://cpaess.ucar.edu/meetings/2021/whole-heliosphere-planetary-interactions-survey>

Magnetosphere Online Seminar Series

From: Kyle Murphy (kylemurphy.spacephys at gmail.com)

We invite you to join us every Monday at 12 pm (EDST, 1600 UT) for the weekly Magnetosphere Online Seminar Series.

Rick Chappell will give our next seminar “The Role of the Earth’s Ionosphere in Populating the Magnetosphere and Driving Its Dynamics” on Monday January 25. A link to join the seminar via Zoom or YouTube can be found on our home page (<https://msolss.github.io/MagSeminars/>). Sign up to obtain the Zoom meeting password.

On Monday February 1 Shasha Zou will be discussing “Multi-scale ionosphere response during geomagnetic storms: Observations, modeling, and machine learning”.

You can view the current 2021 schedule here - <https://msolss.github.io/MagSeminars/schedule.html>

Add your name to the mailing list here - <https://msolss.github.io/MagSeminars/mail-list.html>

And see previous talks here - <https://msolss.github.io/MagSeminars/blog.html>



EUCARA is the European Conference on Amateur Radio Astronomy, held every two year since 2014. The 2020 edition would have been held at the historic Dwingeloo radio telescope again, but due to the pandemic, we've

had to move it to an online conference. This conference will be held on April 17th, 2021. Despite the time zone difference, we would like to extend our invitation to the SARA members as well. And we would also like to invite any of your members to contribute with a presentation on their research or instruments. Could you please forward this invitation to your members? More information about the event can be found at: <http://www.eucara.nl/>



2021 Virtual SKA Science Conference: <https://skao.eventsair.com/science21>

Registration for the 2021 SKA science meeting, entitled “A precursor view of the SKA sky” is now open via the conference website. In the year that marks the establishment of the SKA Observatory, as well as the start of SKA construction activities, we want to bring the focus to science with the new and exciting results that are being produced by the SKA precursors and pathfinders and their implication for SKA. The conference will be a fully virtual event, to be held on 15-19 March 2021. This new virtual format will allow us to welcome participation across all time zones. Our conference will include plenary sessions organized by the SOC, as well as splinter sessions organized independently by the Science Working Groups. The registration fee will be £40 per person (£20 for students).



American Astronomical Society (AAS) & High Energy Astrophysics and Laboratory Astrophysics Divisions ~ *The 238th AAS meeting will be held jointly with our High Energy Astrophysics and Laboratory Astrophysics*

Divisions in Anchorage, Alaska, 6-10 June 2021, and the AAS Executive Office and Vice-Presidents are eager to receive proposals.: <https://aas.org/meetings/aas238>

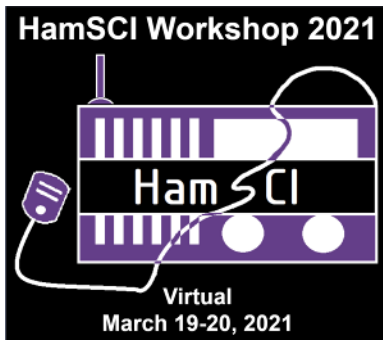

HamSCI Workshop 2021: Midlatitude Science, March 19-20, 2021, A Virtual Workshop Hosted by The University of Scranton:

<https://hamsci.org/hamsci2021>. Come join HamSCI at its fourth annual workshop! Due to restrictions caused by COVID-19, this year's workshop will be held as a free virtual workshop. The meeting will take place March 19-20, 2021 using Zoom Webinar Services hosted by The University of Scranton in Scranton, PA and sponsored by the National Science Foundation. The primary objective of the HamSCI workshop is to bring together the amateur radio community and professional scientists. The theme of the 2021 HamSCI Workshop is midlatitude ionospheric science. Invited speakers include Dr. J. Michael Ruohniemi, Virginia Tech Professor and Principal Investigator of the Virginia Tech SuperDARN Initiative, and Joe Dzekevich K1YOW, an amateur radio citizen scientist who recently published his work in CQ Magazine. Dr. Elizabeth Bruton of the Science Museum of London will be the Keynote Speaker.

From Green Bank Observatory Science Newsletter

(Tentative Dates) May 24-26, 2021: Green Bank Telescope Training Workshop: We expect to open applications for this workshop in February 2021 [at this link](#). This will be a 2.5-day virtual training workshop.

(Tentative Dates) September 13-21, 2021, in Green Bank: The Single Dish Observing School will include a week of astronomy tutorials followed by GBT training workshop. [We will update this page](#) as we have more information. The Green Bank Telescope: 20 Years of Innovation and Discovery: The Green Bank Observatory is commemorating several milestones of the Green Bank Telescope, which was dedicated twenty years ago. Over the coming months many resources will be shared, from archival photos to videos of the GBT's construction, and new interviews with individuals fundamental to the creation of the world's largest fully steerable radio telescope. This will culminate in a [virtual workshop, "The Green Bank Telescope: 20 Years of Innovation and Discovery,"](#) Wednesday-Thursday April 21-22, celebrating the GBT's past achievements and its future projects and science. [See archival videos from the GBT's history here.](#)

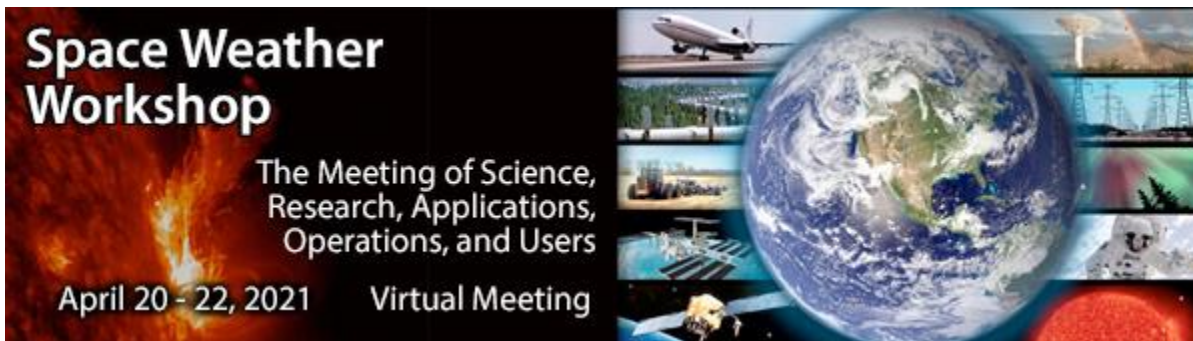

[Space Weather Workshop](https://cpaess.ucar.edu/space-weather-workshop-2021) is an annual conference that brings industry, academia, and government agencies together in a lively dialog about space weather. For additional information and registration: <https://cpaess.ucar.edu/space-weather-workshop-2021>. What began in 1996 as a conference for the space weather user community, Space Weather Workshop has evolved into the Nation's leading conference on all issues relating to space weather. The meeting will span 3 days, Tuesday-Thursday, April 20-22, 2021. Each day will have sessions from 10:00 - 12:00 EDT, 13:00 - 14:30 EDT, and 15:00 - 16:30 EDT with posters from 17:00 - 18:30 EDT. This meeting will be held virtually. Information about the virtual platform and instructions to login to the workshop will be provided to registrants as the workshop date approaches. Plenary presentations are by invitation only. Speakers will be contacted by the organizing committee with instructions. Poster presentations are contributed. More information to follow about submitting posters and presenting. Selected posters will be invited to present 3 to 5 minute "lightning" talks during the oral sessions.

IERS Leap Second Notice

INTERNATIONAL EARTH ROTATION AND REFERENCE SYSTEMS SERVICE (IERS) SERVICE INTERNATIONAL DE LA ROTATION TERRESTRE ET DES SYSTEMES DE REFERENCE

SERVICE DE LA ROTATION TERRESTRE DE L'IERS
OBSERVATOIRE DE PARIS
61, Av. de l'Observatoire 75014 PARIS (France)
Tel.: +33 1 40 51 23 35
e-mail: services.iers@obspm.fr
<http://hpiers.obspm.fr/eop-pc>

Paris, 07 January 2021

Bulletin C 61

To authorities responsible for the measurement and distribution of time

INFORMATION ON UTC - TAI

NO leap second will be introduced at the end of June 2021. The difference between Coordinated Universal Time UTC and the International Atomic Time TAI is:

⚙ from 2017 January 1, 0h UTC, until further notice: $UTC-TAI = -37 \text{ s}$

Leap seconds can be introduced in UTC at the end of the months of December or June, depending on the evolution of UT1-TAI. Bulletin C is mailed every six months, either to announce a time step in UTC, or to confirm that there will be no time step at the next possible date.

Christian BIZOUARD
Director
Earth Orientation Center of IERS
Observatoire de Paris, France

Technical Knowledge and Education

Canadian Centre for Experimental Radio Astronomy (CCERA) ~ Memo 12: *A pulsar observing capability at CCERA*: <http://www.ccera.ca/files/memos/ccera-memo-0012.pdf>

CESRA, Community of European Solar Radio Astronomers ~ *Low frequency radio observations of the 'quiet' corona during the descending phase of sunspot cycle 24*: <http://www.astro.gla.ac.uk/users/eduard/cesra/?p=2698>

Evaluation Engineering ~ *Keep Abreast of RF Filtering Trends (Part 1)*: <https://www.evaluationengineering.com/applications/rf-microwave-test/article/21159131/keep-abreast-of-rf-filtering-trends-part-1>

Everything RF/Copper Mountain Technologies ~ *Amplifier Measurements with a VNA*: <https://www.everythingrf.com/webinars/details/639-amplifier-measurements-with-a-vna>

Rigol ~ *Basic Measurements with a VNA*: <https://www.rigolna.com/vna-app-note/>

Electronic Design ~ *Multimeter Measurements Explained*: <https://www.electronicdesign.com/technologies/test-measurement/article/21146730/13harris-technologies-multimeter-measurements-explained>

SDRPlay ~ *Understanding Radio Communications*. This course provides an interesting and practical way to learn about digital wireless communications and to put the techniques to work receiving telemetry from the hundreds of "CubeSats" in orbit around the Earth. It is a fun way to learn important things!: <https://www.sdrplay.com/understandingradio/>

Square Kilometre Array (SKA) ~ All issues of the monthly SKA-France newsletter are available online at the SKA-France web page: <https://ska-france.oca.eu/fr/bulletins>

All About Circuits ~ *Understanding Radiated Electromagnetic Compatibility Tests*: <https://www.allaboutcircuits.com/technical-articles/understanding-radiated-electromagnetic-compatibility-emc-tests/>

Hey, Mac, "a horn in every backyard": West Virginia University ~ *Digital Signal Processing in Radio Astronomy* - This website is a culmination of efforts to bring every aspect of Radio Astronomy to the classroom environment. This collection includes lessons and activities in Engineering and Astronomy appropriate from middle school students to citizen scientists: <https://wvurail.org/dspira-lessons/>

Digi-Key ~ *Product Training Module Library, Increase Your Knowledge of the Latest Products and Technologies*: <https://www.digikey.com/en/ptm>

Rigol ~ *App Note - Advanced Measurements with a Vector Network Analyzer*: <https://www.rigolna.com/vna-app-note/>

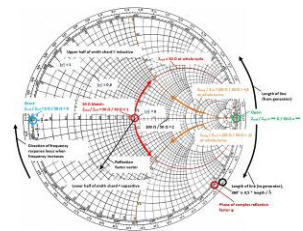
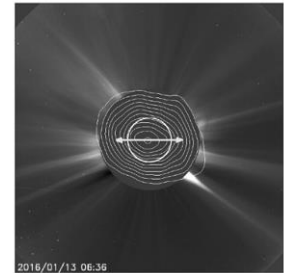

American Geophysical Union ~ *A Fresh Look at Jovian Decametric Radio Emission Occurrence Probabilities in the CML-Io Phase Plane*: <https://agu2020fallmeeting-agu.ipostersessions.com/Default.aspx?s=32-A3-44-20-C9-2D-4A-0C-32-1B-BF-24-44-37-32-C3&pdfprint=true&guestview=true>

The SETI Project: <https://exoplanetschannel.wixsite.com/home/setiproject>

CESRA, Community of European Solar Radio Astronomers ~ *Radio bursts in the 2017 September 6, X9.3 flare*: <http://www.astro.gla.ac.uk/users/eduard/cesra/?p=2725>

Vicor Inc. ~ *EMI challenges and troubleshooting techniques webinar*: <http://www.vicorpower.com/resource-library/webinars/emi-challenges>

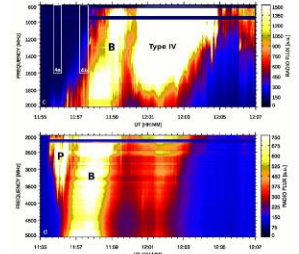

Keysight Technologies ~ *RF and Signal Chain Analysis webinar series*: <https://stream.dcasf.com/webinar/the-rfmicrowave-signal-chain/>



Rohde & Schwarz ~ *Everything Test Webinar series*: https://www.rohde-schwarz.com/us/campaigns/rsa/icr/everything-test-webinar-series_254047.html



Copper Mountain Technologies ~ *VNA Master Class – Webinar Series*: <https://coppermountaintech.com/webinar-series/>



Copper Mountain Technologies ~ *Webinars*: <https://coppermountaintech.com/webinars/>

Hey, Mac, here we go again – predicting the future: *Overlapping Magnetic Activity Cycles and the Sunspot Number: Forecasting Sunspot Cycle 25 Amplitude*: <https://arxiv.org/pdf/2006.15263.pdf> . For a recorded presentation called *Solar Cycle 25 Prediction and Why*, by one of the authors, Dr. Scott McIntosh, see: [https://us02web.zoom.us/rec/share/NMlTa_PcxJMN335-sN-Hhq5t1WzbmTY-qNTDt1SCedeR9pxPdG6o3p_046iVtmAl.qEgoEo-6p34nOrm](https://us02web.zoom.us/rec/share/NMlTa_PcxJMN335-sN-Hhq5t1WzbmTY-qNTDt1SCedeR9pxPdG6o3p_046iVtmAl.qEgoEo-6p34nOrm?with_passcode=z7qCn@3G) with passcode: z7qCn@3G. Scott was one of the guest speakers at the 2019 SARA Western Conference in Boulder, Colorado.

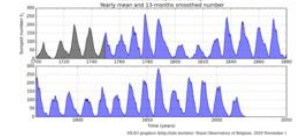

Testforce and Tektronix Web Training ~ *How to Simplify EMI/EMC Measurement in Your Lab*: <https://www.everythingrf.com/webinars/details/996-how-to-simplify-emi-emc-measurement-in-your-lab-testforce-and-tektronix-web-training>



The Astronomer's Telegram ~ *Detection of radio emission from SGR 1935+2154 at the frequency 111 MHz*: <http://www.astronomerstelegram.org/?read=14186>

Cornell University ~ *A high-rate foreground of sub-second flares from geosynchronous satellites*: <https://arxiv.org/abs/2011.03497>

Microwaves & RF Library eBook ~ *What's the Difference Between...*, Vol. 1: <https://www.mwrf.com/learning-resources/whitepaper/21142162/mwrfwhats-the-difference-between-vol-1>

Evaluation Engineering ~ *Multimeter Measurements Explained*: <https://www.evaluationengineering.com/applications/article/21161246/multimeter-measurements-explained>

Mini-Circuits ~ *Using RF Balun Transformers for Bias Injection, DC Isolation and Even Order Harmonic Suppression:*

<https://www.youtube.com/watch?v=2I7IZujamtU&feature=youtu.be>

Radio Meteor Detection Collaboration Project:

<https://radiometeordetection.org/about>

CESRA, Community of European Solar Radio Astronomers ~ *Estimate of Plasma Temperatures across a CME-driven Shock from a Comparison between EUV and Radio Data:* <http://www.astro.gla.ac.uk/users/eduard/cesra/?p=2735>

Cornell University ~ *Unexpected Circular Radio Objects at High Galactic Latitude:*

<https://arxiv.org/abs/2006.14805>

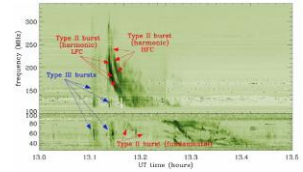
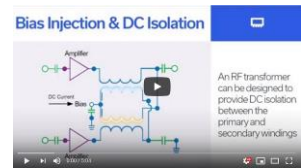



For Your Radio Astronomy Bookshelf

(Prices in USD)

- ⚙ **Fundamentals of Radio Astronomy Observational Methods**, Marr, J.M.; Snell, R.L.; Kurtz, S.E.; 2016, CRC Press, \$110.00 (hardcover)
- ⚙ **Galactic Radio Astronomy**, Sofue, Y., ISBN 978-981-10-3444-2, Springer, \$64.99 (hardcover)
- ⚙ **Handbook of Pulsar Astronomy**, Lorimer, D.R.; Kramer, M.; ISBN 0-521-82823-6; 2005, Cambridge University Press; \$94.00, (hardcover)
- ⚙ **Pulsar Astronomy**, Lyne, A.G.; Graham-Smith, F. ISBN 0-521-32681-8, 1990, Cambridge University Press; \$47.95 (hardcover)
- ⚙ **Radio Astronomy**, 2nd Ed.; Kraus, J.D., ISBN 65-28593, 1986, McGraw-Hill, Inc. \$49.95 (spiral bound)
- ⚙ **Tools of Radio Astronomy**, 6th Ed., Wilson, T.L.; Rohlfs, K.; Hüttemeister, S.; ISBN 3662517329, Springer, \$118.00 (hardcover)

Book Review

Title: *OPEN SKIES, The National Radio Astronomy Observatory and Its Impact on US Radio Astronomy*

Authors: Kenneth I. Kellermann, Ellen N. Bouton and Sierra s. Brandt

ISBN: 1775292142

Status: In print

Availability: Kindle Amazon Prime (Free)

Reviewer: Dennis Farr

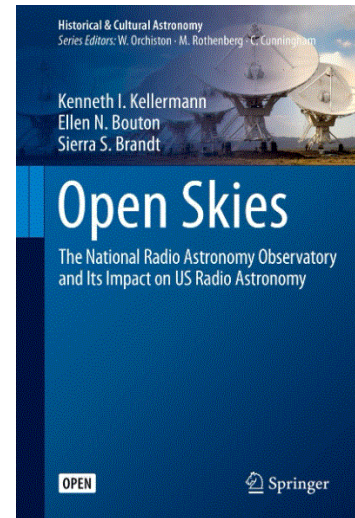

This book starts with the earliest discoveries of Karl Jansky and continues through the VLBA. It is a history of the NRAO with side stories about all the famous people we have all heard about in radio Astronomy.

Kenneth I. Kellerman was an employee of NRAO and worked with many of the people who created it and/or worked there.

It is the not so hidden story of the politics involved when big money and academia meet.

I was led to believe that Jansky had nothing but a passing interest in radio astronomy, but the story told by Kellerman is that he would have liked to pursue the topic, but there was no budget for it and he had to give it up. Fortunately, Grote Reber was able to continue work in the pre-WWII days from his home outside Chicago. Grote eventually worked in Australia, a major competitor for radio astronomy projects. Interestingly, his ashes are distributed among many radio observatories around the world.

Anyone that has been to Green Bank Observatory has seen the 140' telescope. The largest GEM mounted telescope in the world. Strangely enough, it was nearly the death of Green Bank and NRAO.

Read the history of the 300' dish, and the GBT that replaced it.

The book reads like a genealogy and you will find yourself skipping over numerous lists of names of people that attended this or that conference. The level of detail is mind boggling.

This book is free on Amazon if you have a prime membership. I highly recommend it if you want a detailed history of radio astronomy and NRAO.



The British Astronomical Association

A company limited by guarantee

Registered Charity No. 210769

Burlington House, Piccadilly, London, W1J 0DU

Telephone: 020 7734 4145

Fax No.: 020 7439 4629

Email: office@britastro.org

Website: www.britastro.org



Please send all reports and observations to jacook@jacook.plus.com

The British Astronomical Association Solar Report

BAA Radio Astronomy Section

2020 NOVEMBER

Activity in November was the highest so far recorded in 2020, and shows that solar cycle 25 is now well underway. There have been numerous B-class flares as well as plenty of smaller C-class, but we were also very lucky to catch a good M4.4 flare on the 29th. This is the second M-class flare so far, an M1.1 being recorded in May.

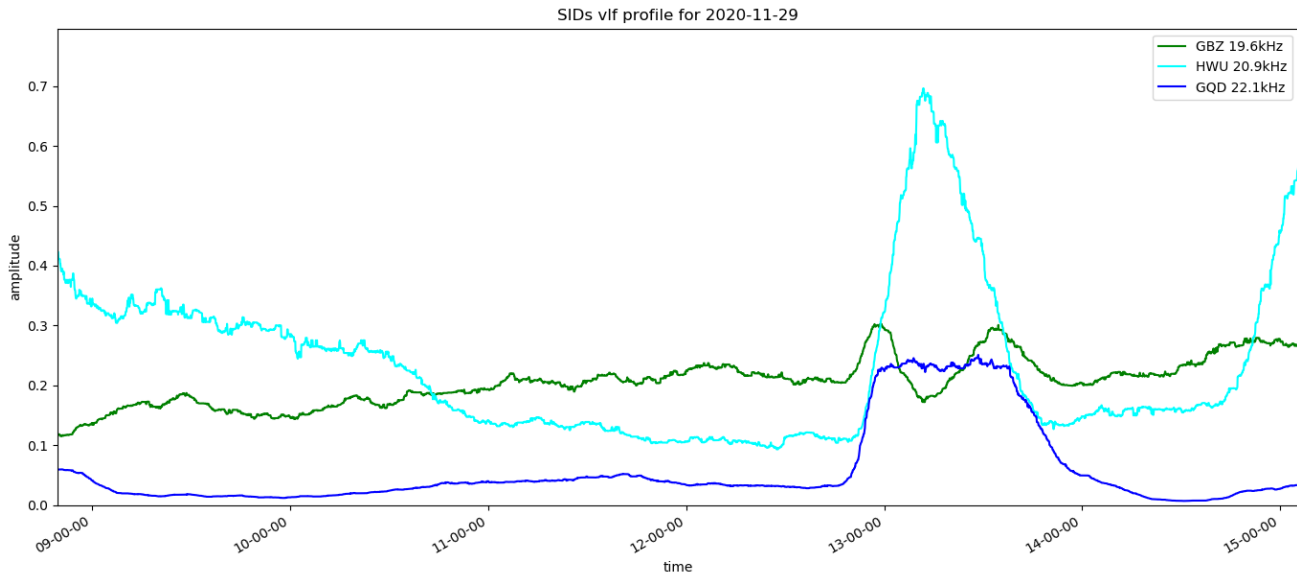

This recording by Mark Prescott shows the flare clearly, the 20.9kHz signal (light blue) showing a very symmetrical SID. 19.6kHz (green) shows a 'spike and wave' SID, often seen with stronger flares. This is due to the ground-wave / sky-wave interference pattern moving from adding to cancelling at the peak of the flare, and then reversing back again as the flare decays. The 22.1kHz SID is rather unusual, with a flat top. I have not seen one quite like that before. The flare itself had a normal peak, and a very long decay taking over four hours to drop below C-class.

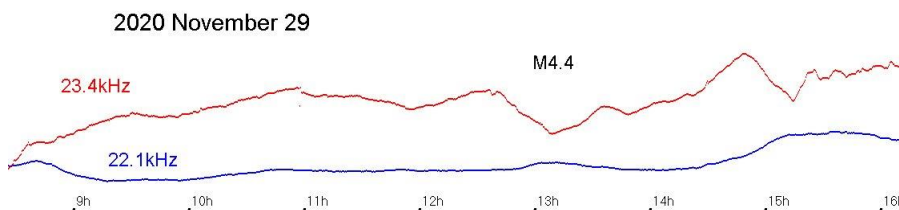

My own recording (above) shows a very weak response at 22.1kHz, but does show the long decay at 23.4kHz, the signal merging with the early sunset in late November.

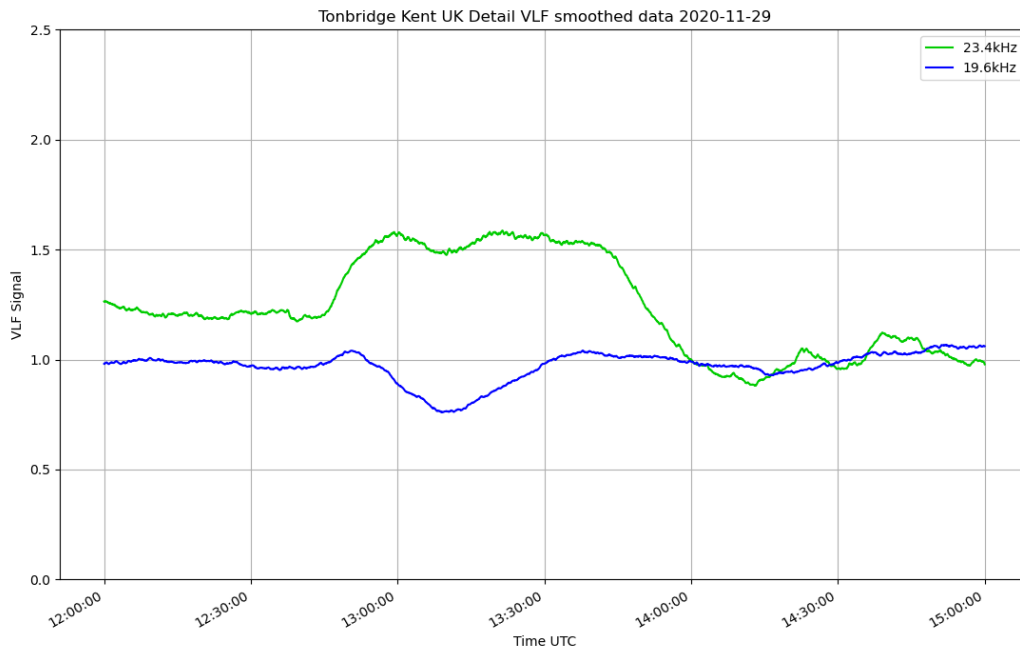

This chart from Andrew Thomas shows a nearly flat top at 23.4kHz, but with a small dip around the peak time, like the 'spike and wave' SID but with a long decay time. I suspect that the 22.1kHz SID in Mark Prescott's recording may be due to the interference pattern just reaching the cancelling phase, but then remaining steady at that point until the long decay takes over.

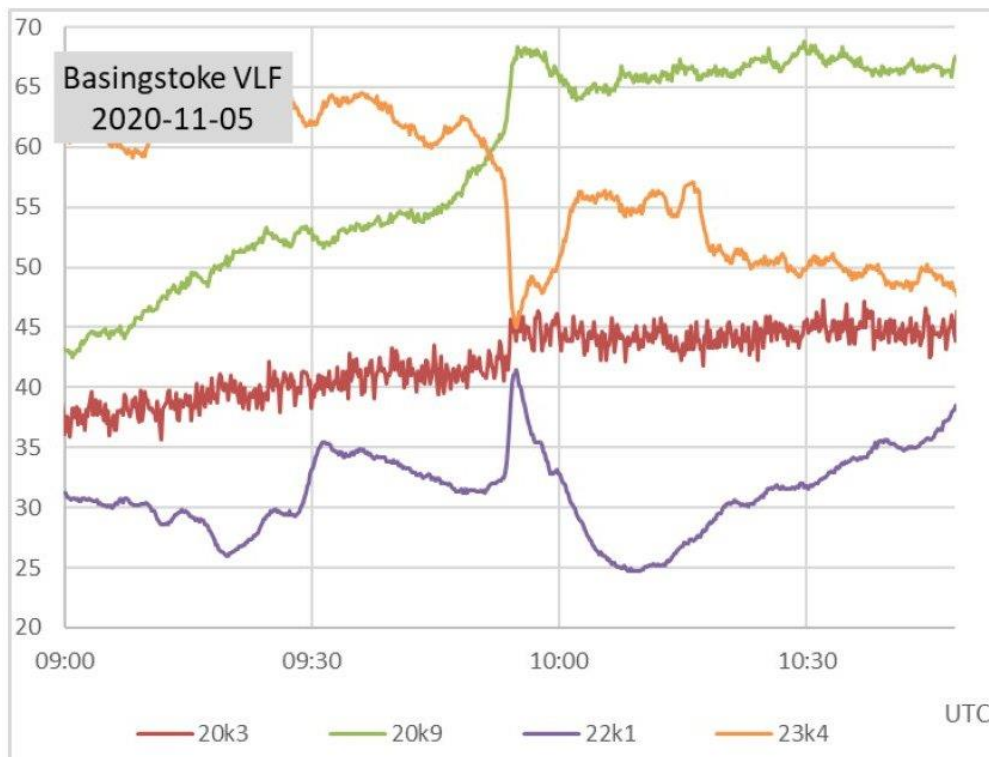

November 5th recorded the largest number of SIDs, although they were all from smaller C-class flares. This recording from Paul Hyde shows the C2.3 flare peaking at 09:55UT on four rather noisy signals. The longer path at 20.3kHz from Italy is particularly noisy, almost hiding the SID. This was the strongest flare recorded on the 5th, the remaining activity shown on the next page. The C1.4 flare at 12:30 shows a smaller peak at 12:23 that is not classified in the SWPC data. The later C1.0 flare is just visible at 37.5kHz, but well hidden on the other signals.

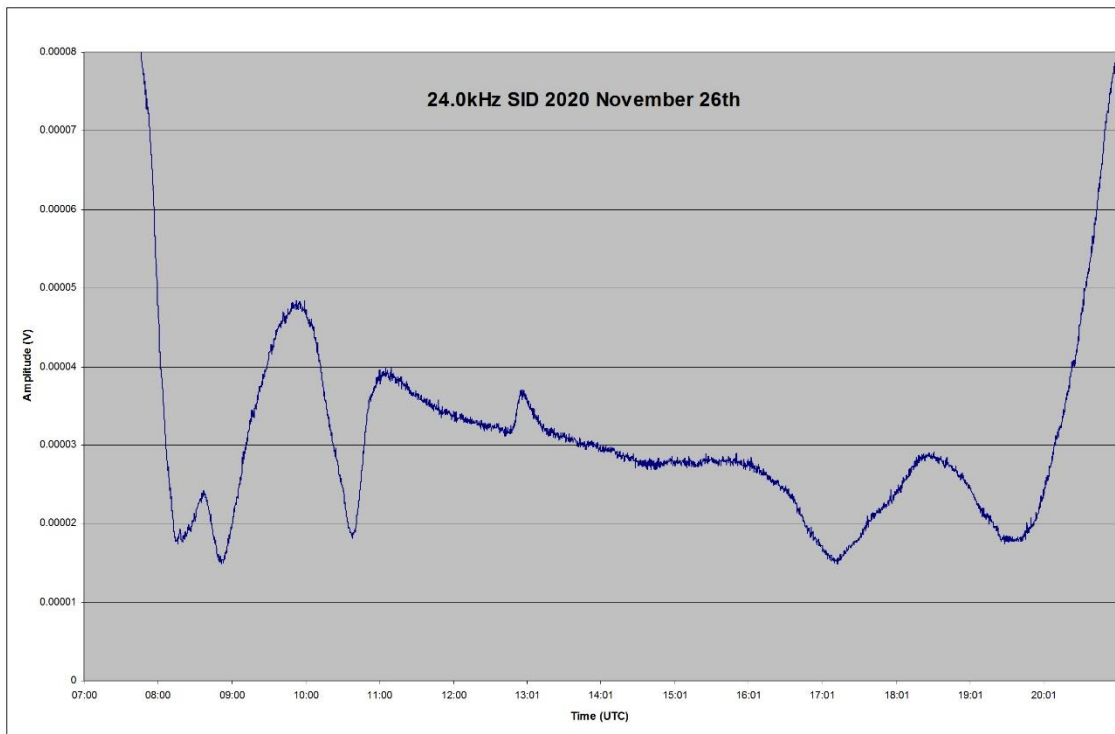
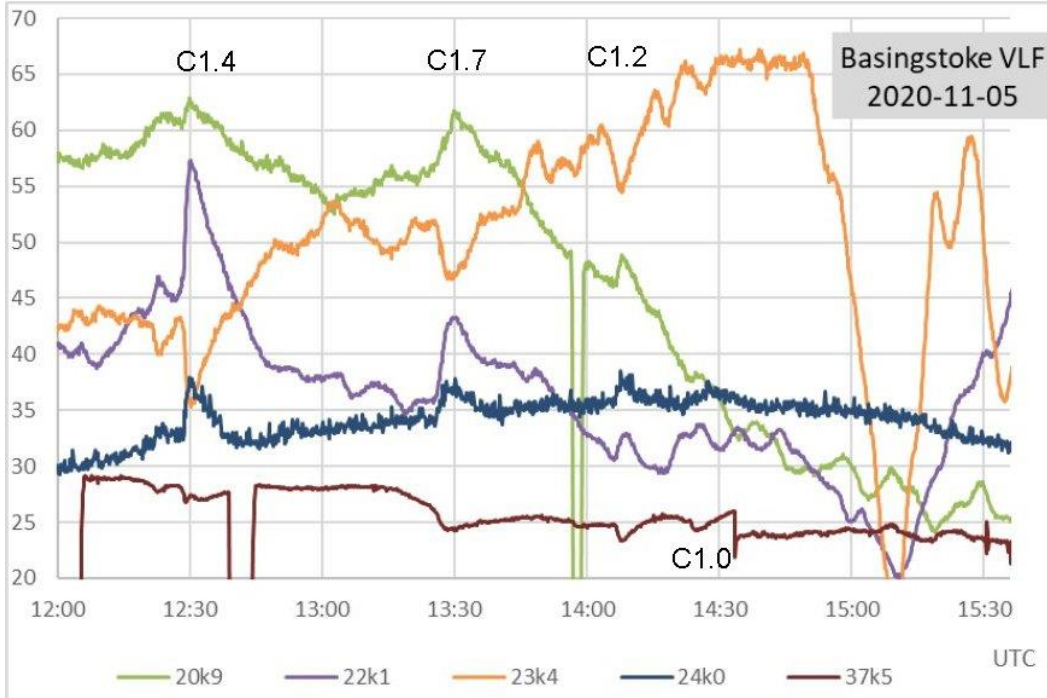

This recording by Mark Edwards shows a well defined SID peaking at 12:56UT at 24kHz, from a C2.3 flare on the 26th. For a change, we have a fairly noise-free signal all day, showing the sunrise and sunset effects.

MAGNETIC OBSERVATIONS

Most of the flaring activity reported above was from active regions close to the eastern limb of the sun as seen from Earth. There were a number of associated CMEs, the majority of which were aimed well away from Earth and so had little effect.

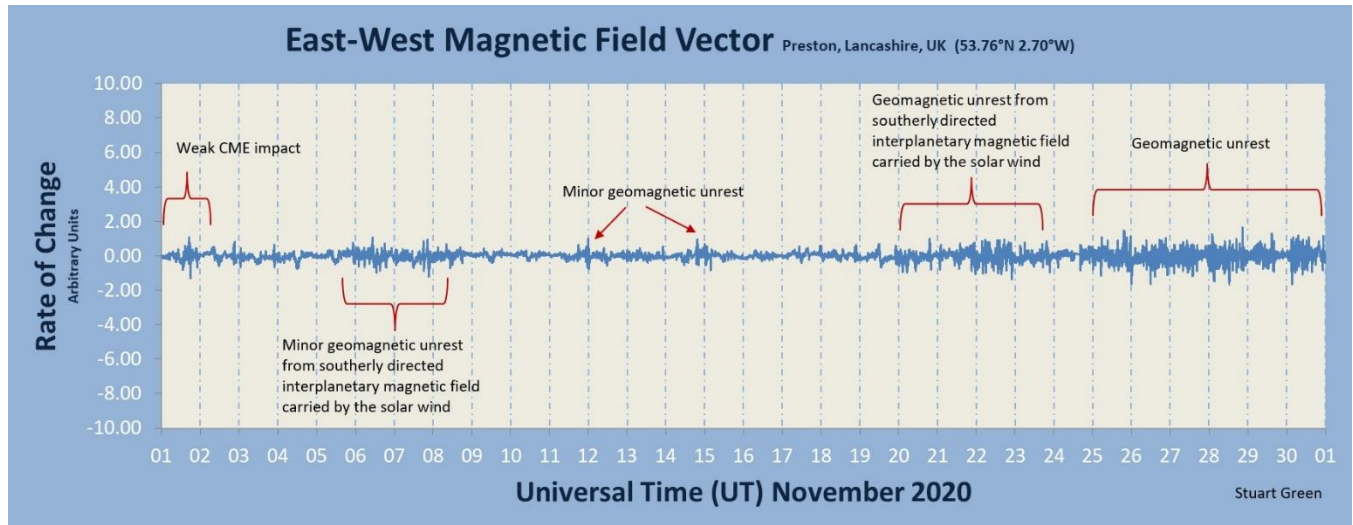

Stuart Green’s summary of the month’s activity shows a very weak CME impact on November 1st, with solar wind disturbances later in the month. Satellite images indicate that the CME was from a filament eruption seen on October 27th. The northern polar coronal hole seen over the last few months made another appearance on the 20th with a very mild disturbance, increasing in the evening of the 21st. The most active disturbance was on the 22nd, shown in this recording by Colin Clements:

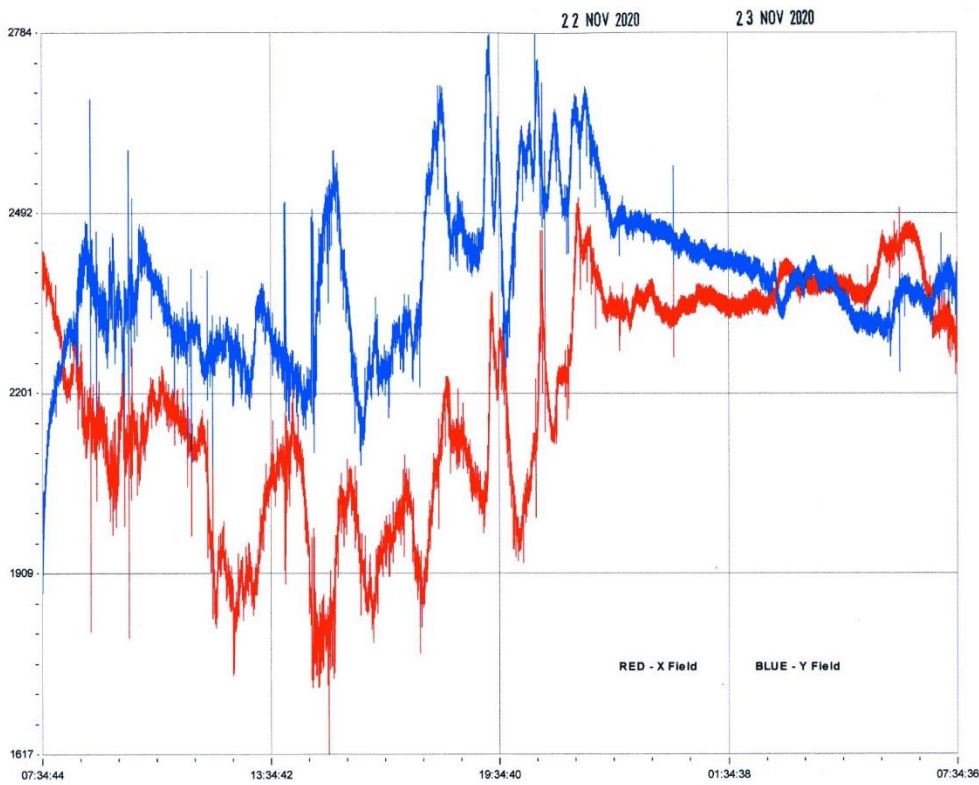

The disturbance was particularly turbulent in the evening, with rapid variations of about ± 50 nT. This ended quite suddenly just before midnight, with only a mild disturbance recorded on the 23rd. It did recover for a while in the evening of the 25th.

A southern coronal hole produced a relatively slow solar wind that merged with the edge of some of the eastern limb CMEs mentioned earlier. This produced some more rapid magnetic variations on the 6th, but of very low amplitude. Minor disturbances continued on the 7th, as shown in the recording by Roger Blackwell on the next page:

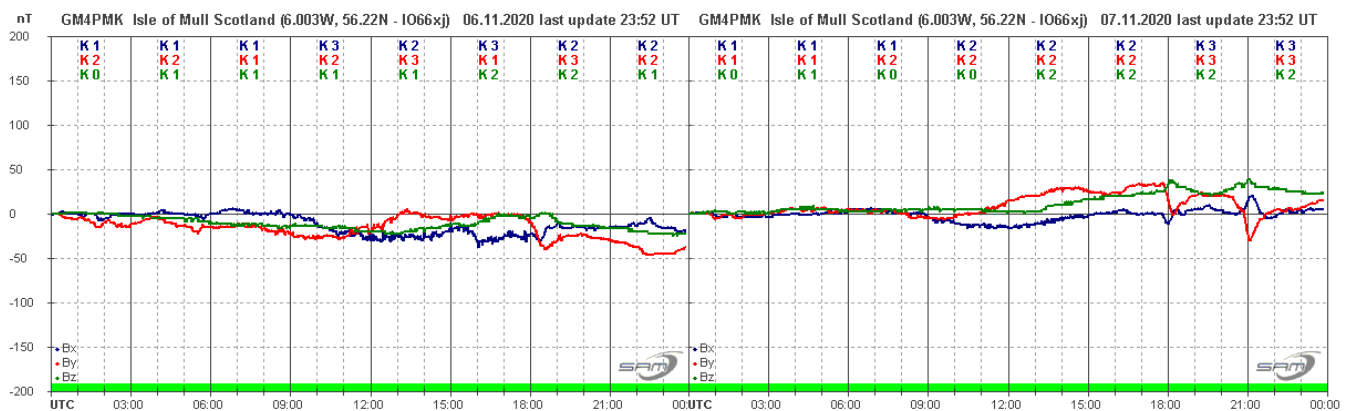

Magnetic observations received from Roger Blackwell, Colin Clements, Stuart Green, Andrew Thomas and John Cook.

METEORS

Philip Rourke sent in this unusual meteor reflection recorded on the 18th using the GRAVES radar:

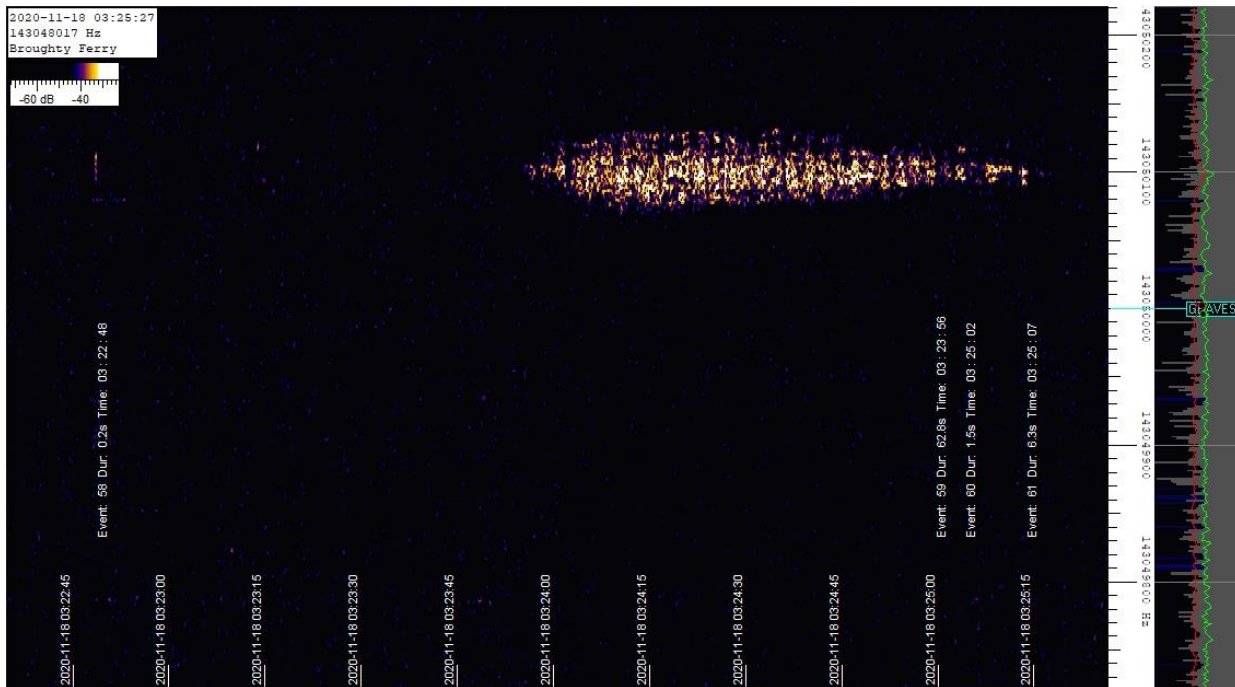

The trail starts at 03:24:00, ending at 03:25:15, so lasting 75 seconds. Philip described it as 'fish-shaped', a good description. Leonid meteors are noted for the high speed ($\sim 70\text{km/s}$), but often leave persistent trails. The timing of this event is certainly good for a Leonid, although it could also be a sporadic of course. No other Leonid reports were received.

BAA Radio Astronomy Section

2020 DECEMBER

Solar activity in December was much lower than last month, with just three flares recorded as SIDs. There were a number of active regions present, but they produced mostly small B-class flares that were not detected in the very noisy winter signals. The strongest flare of the month was the C7.4 on the 7th, although it was poorly timed during the sunset period for European signals.

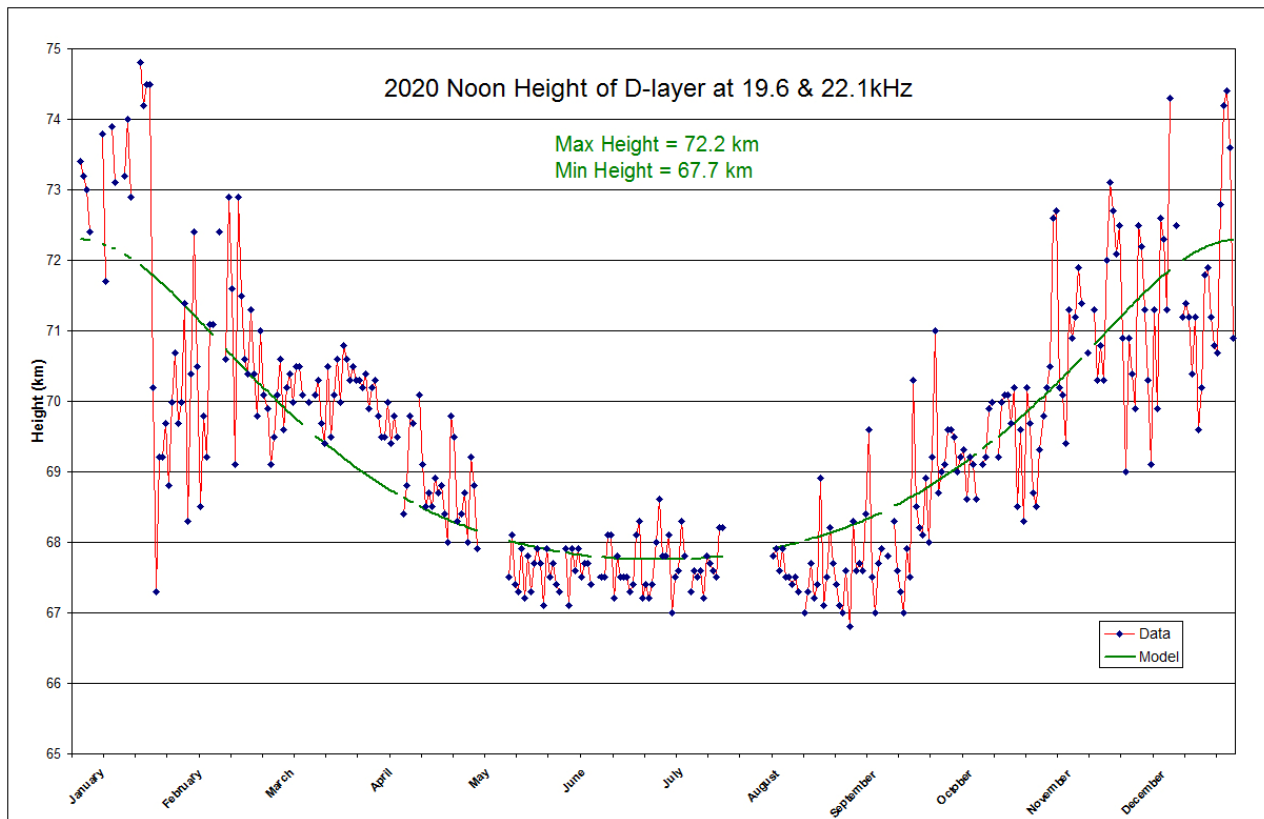

Mark Edwards has provided his modelling of the noon-height of the D-region measured using the paths to Skelton and Anthorn. Gaps in the green trace are where one of the signals was off-air.

	2011	2012	2013	2014	2015	2016	2017	2018	2019	2020
Max	71.6	71.8	71.4	71.0	69.9	70.8	72.4	73.2	72.3	72.2km
Min	67.0	66.8	66.8	67.2	67.3	67.6	67.3	67.3	67.4	67.7km

The 2011 data represents the first year of stronger cycle 24 activity, with a short peak in 2012 and a longer peak in 2014/15. 2020 has seen the start of cycle 25 activity, but very patchy as the activity chart shows.

VLF interference has been a problem for some observers, with LED lights and solar panels identified as sources. Paul Hyde has recently discovered that an induction-hob cooker can also be a source of interference. I wonder, has anyone else had a similar problem?

MAGNETIC OBSERVATIONS

The C7.4 flare recorded on the 7th produced a CME, with a magnetic signature recorded at 02:10UT on the 10th on my magnetometer. This gives a CME transit time of 57h 40m. It shows well on the chart from Roger Blackwell:

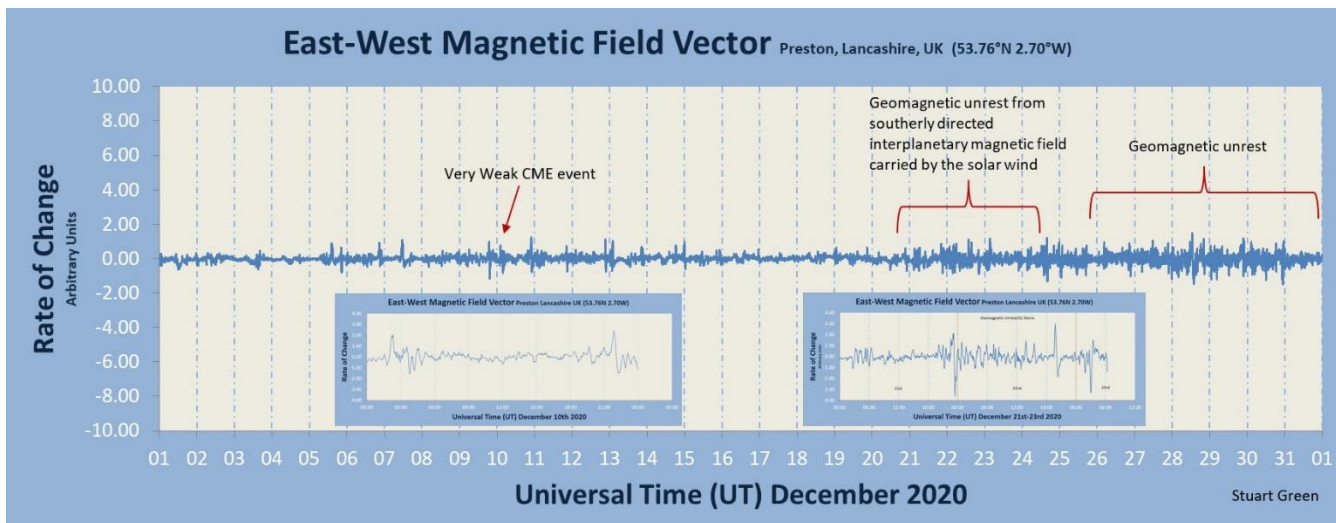
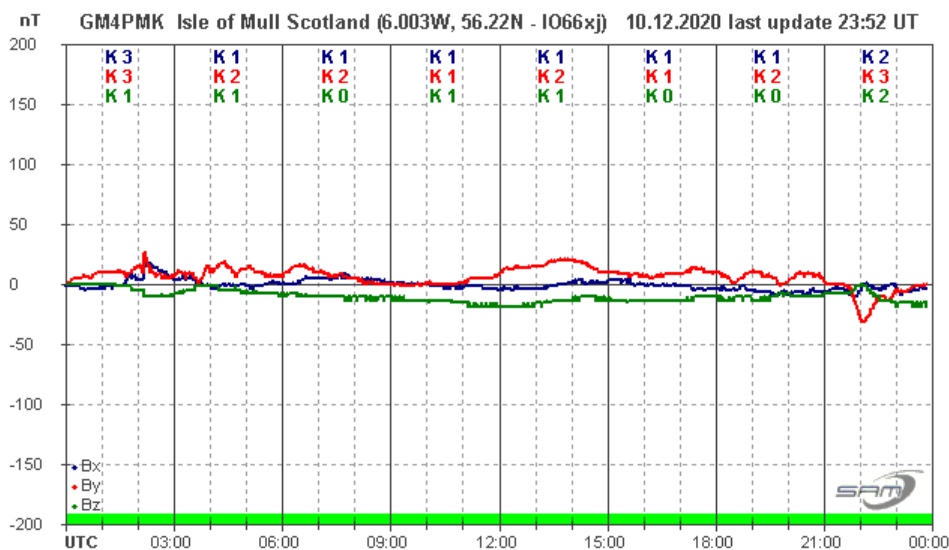

The month's summary chart from Stuart Green shows that there was very little magnetic disturbance following the initial CME impulse. The recurrent coronal hole recorded since 2020 July has faded, with only some very mild disturbance recorded on this rotation. Roger Blackwell's recordings show a sudden disturbance late in the evening of the 21st followed by a very mild disturbance until 19:30 on the 22nd and a second, smaller pulse of activity. Effects on the 23rd and 24th were also very mild.

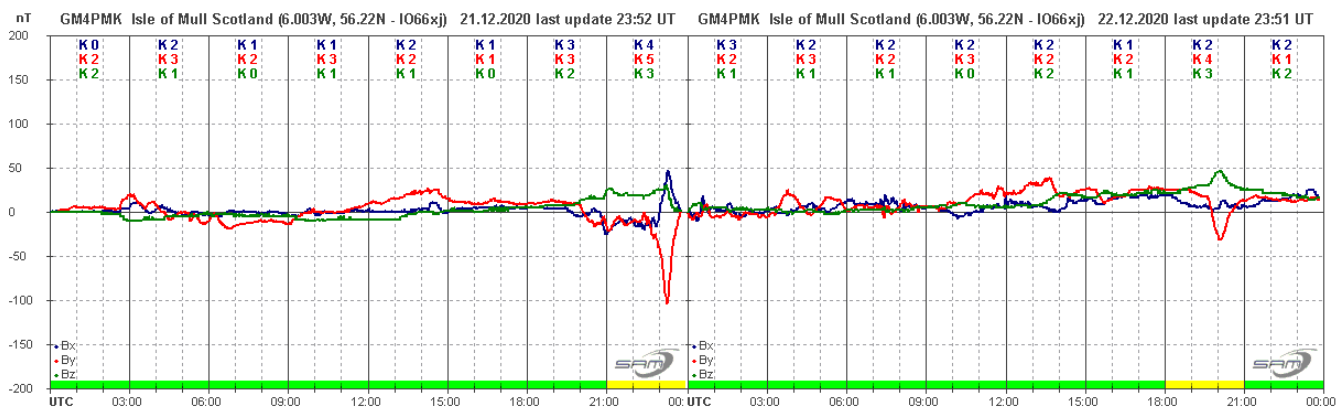

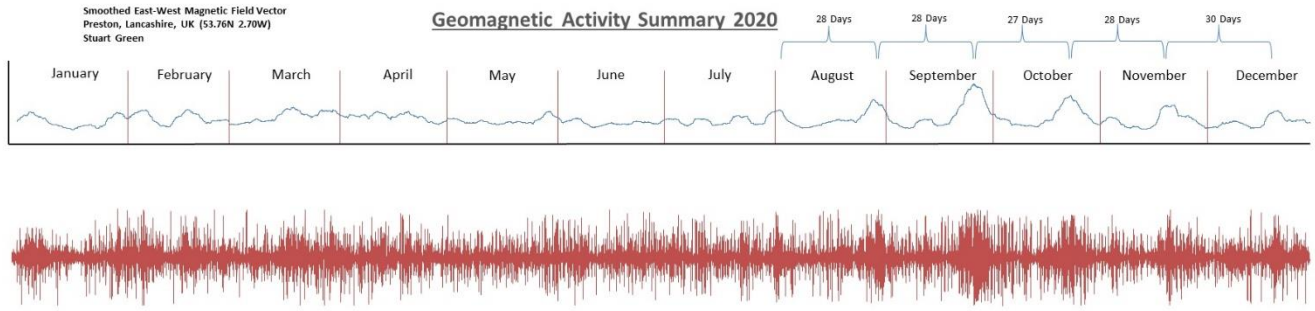

This chart from Stuart Green shows a summary of magnetic activity through 2020. Over the first six months there were random periods of activity, but a more regular 28 day pattern can be seen from the end of July. This matches well with that recurrent coronal hole. The bartels diagram uses a 27 day cycle, and so this 28 day period causes the activity to move one day to the right on each line of the chart. The 27 day period was based on sunspot activity nearer the solar equator, which has a faster rotation period than the higher latitude area of this coronal hole. The most active period at the end of September stands out well in both charts.

Magnetic observations received from Roger Blackwell, Colin Clements, Stuart Green and John Cook.

VLF flare activity 2005/20

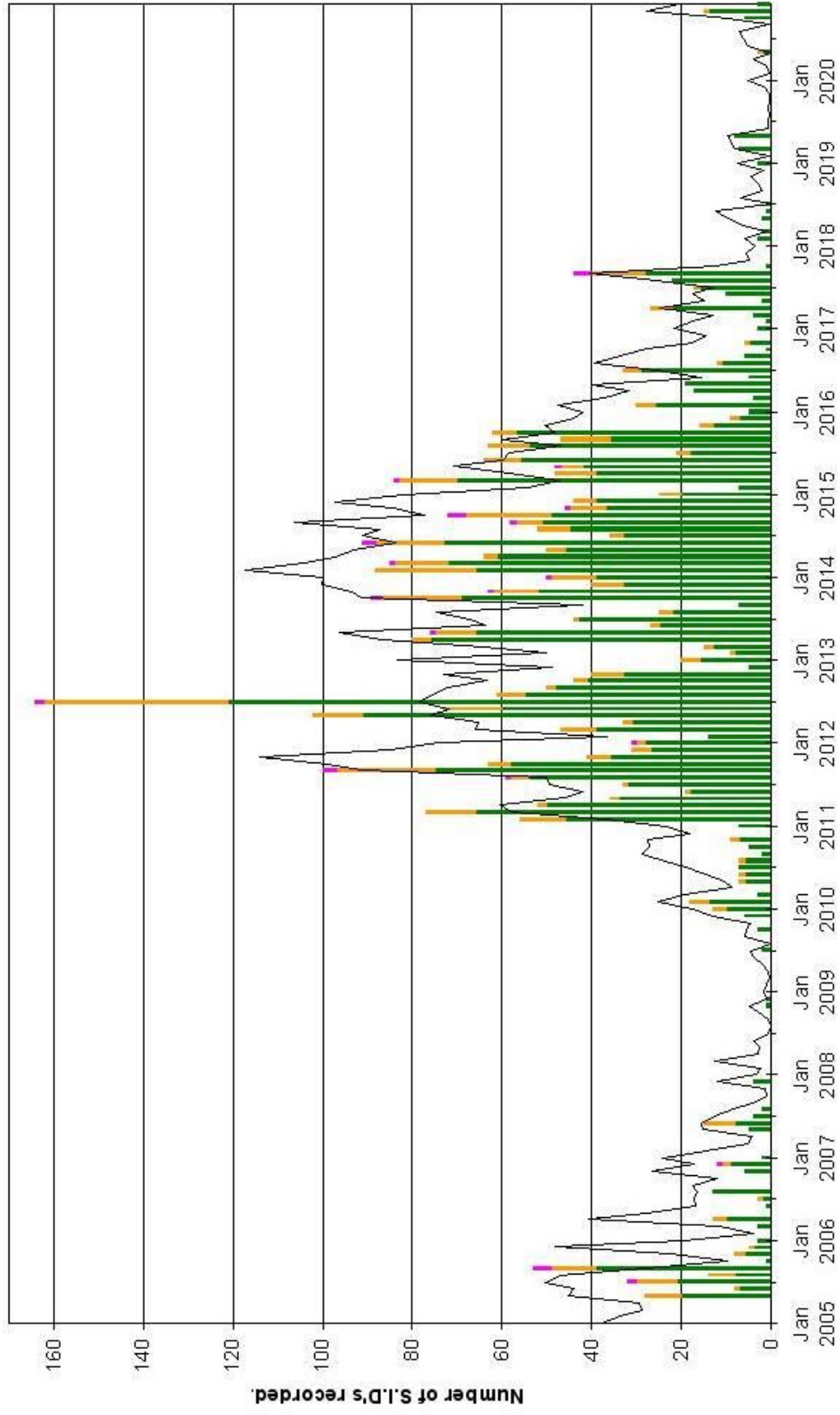

70th Anniversary of the Discovery of Radio Emissions from Neutral Hydrogen

David K. Ewen (PAASEinst@gmail.com) sent SARA the following. David is the son of Harold "Doc" Ewen and he supplied the transcript of a conversation between Doc Ewen and Ed Purcell and the images below. See original article about the discovery in the 1 September 1951 issue of [[Nature](#)].

True space exploration began in 1951 at Harvard University. We are approaching the celebration of the 70th anniversary on March 25, 2021. On March 25th, 1951, the very first detection of hydrogen using a radio telescope with a horn antenna sticking out of a window on the 4th floor of the Lyman Physics laboratory at Harvard University was accomplished. This capability is the foundation of further discoveries allowing us to see the universe in a way never possible before. In 1951, on the 4th floor of the Lyman Laboratory, Harold "Doc" Ewen, Ph.D. was the first to observe and detect neutral hydrogen. His Harvard University thesis advisor was Edward, M. Purcell, Ph.D. This day made history in scientific space exploration.



Harold "Doc" Ewen, Ph.D. and Horn Antenna mounted on 4th floor window of Lyman Physics Laboratory at Harvard University Used to Detect Neutral Hydrogen on March 25, 1951

Since that time, radio astronomy has detected many new types of objects including pulsars and quasars. We can see a universe that radiates at wavelengths and frequencies we can't see with our eyes. Objects in the universe give off unique patterns of radio emissions. Different wavelengths are generated by different objects and radio astronomers use a variety of methods and instruments to detect them. The radio signals detected by radio telescopes are converted into data that can be used to make images. For example, they are used to measure clouds of gas, which are abundant in the spiral arms of the Milky Way Galaxy making it possible to map the galaxy's overall layout. Today, new radio telescopes provide ever more detailed views of the Milky Way.

In radio astronomy, radio waves that are in the electromagnetic spectrum, and radio astronomers use radio waves to see through all the large clouds of dust and darkness, to show even how gases swirl around Neptune and Uranus. When the hydrogen atoms crash, they make a bigger atom called a star, and a radio telescope helps us learn about them more by showing us those stars near us. Also, if you want to see some weird objects in the universe and even solve some mysteries, use radio telescopes.

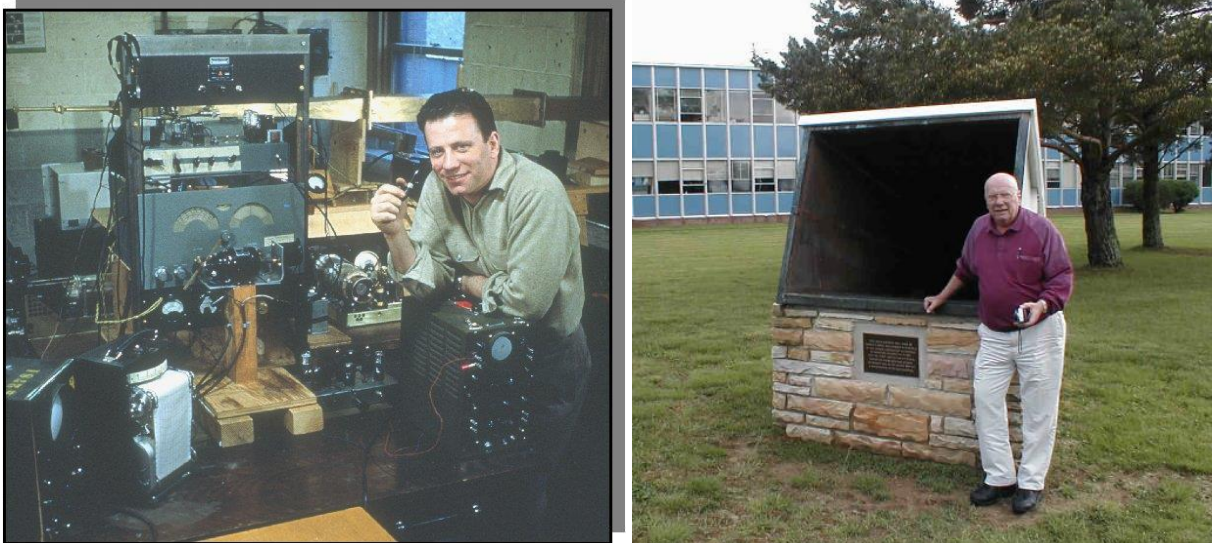

Left: Harold "Doc" Ewen, Ph.D. in 1951 (note waveguide from the horn antenna at head level behind Ewen); Right: Harold "Doc" Ewen, Ph.D. and the Horn Antenna at Green Bank Observatory.

In 1987 Harold "Doc" Ewen and Edward M. Purcell, Ph.D. looked back to reminisce and spoke about the events that occurred on Easter weekend on the morning of March 25, 1951 that would forever change how we looked at our universe.

Doc Ewen – Originally, we didn't know whether the radio waves would actually be detectable. And the only thought at the time was if they were, they probably would be concentrated somewhere along the Milky way. And as a result, the best place to be looking would be toward the South in the vicinity, just north of Sagittarius, which is the center of the Milky way or our galaxy and just take a chance on the fact that there's a good concentration of material there.

Ed Purcell – Well, actually a good deal had been deduced from rather indirect evidence by the astrophysicist concerning the gas in our galaxy. And people know it was mostly hydrogen and that it was very empty. There were very few gas atoms per cubic centimeter. And in this empty thing, they're emitting this very thing, very characteristic radiation. The amount of hydrogen out there, and his temperature was such that the radiation at this frequency that we're concerned with is very special frequency amounted to only one watt landing on the entire earth.

Doc Ewen – To attempt to detect a signal of that intensity less than a million millionth part of a lot, as far as what I was dealing with would be extremely difficult, even building an excellent radar receiver. I was concerned that we might be dealing downstream somewhere with a negative thesis and a negative thesis is extremely difficult and could take an extra year or two to tidy up and calibrate and put some numbers on it. If you don't detect something, then you must carefully state at what level you're capable or incapable of detecting it. So that was my concern. Ed's comment [Edward M. Purcell, Ph.D.] to that was so it's a couple of years of your life and but it's certainly worth it. And if you do detect it, you'll be in LIFE magazine and he was right.

Ed Purcell – Well, as I remember, it was in the morning. So, he'd been up all night and I'd been at home in bed. And as I remember, he said, I think I have a thesis. And I came dashing over.

Doc Ewen – It was over the weekend of Easter. And the first time I turned on the scanning of such as I was tuning, looking for this hydrogen hyperfine station, broadcasting from space, I was tuning through the spectrum. As you might just turn a knob. And I noticed at the end of the first scan, the signal was on its way up.

Ed Purcell – And here on the Esterline paper from Esterline Angus Recorder, you know, it looked as wiggly line and looked as though there might be some bumps in and we rolled out about 20 feet of it and got down inside it along it, you see? And then we can see this bump like that.

Doc Ewen – It's just the way you designed it. It's just the way you thought about it. There was just a chill goes up your back and you say, I got it. And you'll just never, ever forget the excitement of doing something like that. And yet it's so common in the field of science to go through these steps and feel that excitement. It's just beautiful.

The 70th-anniversary celebration of the first detection of the hydrogen gas in the milky way at a 21 centimeter wavelength in 1951 by Harold “Doc” Ewen and Prof. Edward M. Purcell, his thesis advisor at Harvard University, will be hosted by the P.A.A.S.E Institute <https://about.me/paase> (a consortium of Professional Astronomers, Astrophysicists, and Space Explorers) in partnership with Harvard University, the National Radio Astronomy Observatory, and Green Bank Observatory.

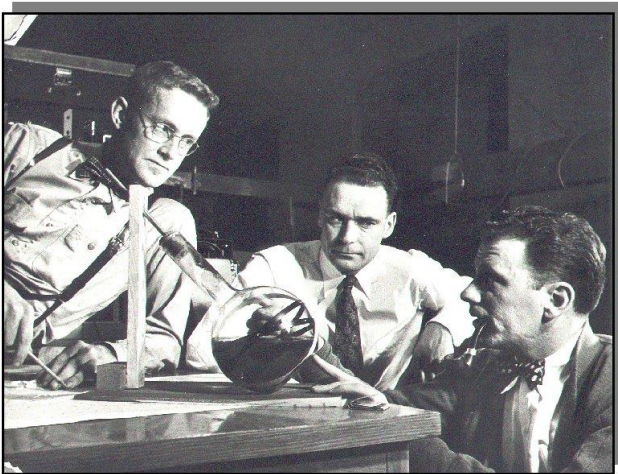

Left to right: Ed Purcell, Taffy Bowen, Doc Ewen

[[Nature](#)] Ewen, H.I., Purcell, E.M. Observation of a Line in the Galactic Radio Spectrum: Radiation from Galactic Hydrogen at 1,420 Mc./sec.. *Nature* **168**, 356 (1951). <https://doi.org/10.1038/168356a0>:



SuperSID
*Collaboration of Society
of Amateur Radio
Astronomers and
Stanford Solar Center*



- ✓ Stanford provides data hosting, database programming, and maintains the SuperSID website
- ✓ Society of Amateur Radio Astronomers (SARA) sells the SuperSID monitors for 48 USD to amateur radio astronomers and the funds are then used to support free distribution to students all over the world (image below as of Fall 2017)
- ✓
- ✓ Jonathan Pettingale at SARA is responsible for building and shipping the SuperSID monitor kits: SuperSID@radio-astronomy.org
- ✓ SuperSID kits may be ordered through the SARA SuperSID webpage: <http://radio-astronomy.org/node/210>
- ✓ Questions about the SuperSID project may be directed to Steve Berl at Stanford: steveberl@gmail.com
- ✓ Jaap Akkerhuis at Stanford is responsible for the SuperSID software and SARA has provided financial support for his efforts
- ✓ SuperSID website hosted by Stanford: <http://solar-center.stanford.edu/SID/sidmonitor/>
- ✓ SuperSID database: <http://sid.stanford.edu/database-browser/>
- ✓ The data is searchable by time, station, date, and multiple plots may be placed on the same graph for comparison
- ✓ Support also is provided through the Yahoo SuperSID group: https://groups.yahoo.com/neo/groups/Super_SID/info

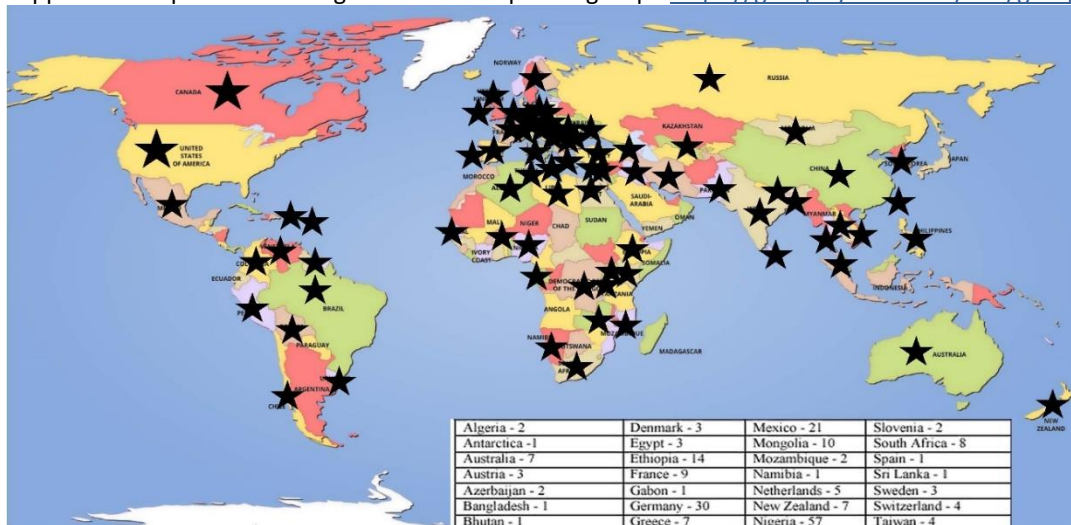

**SID Monitor
Distribution**
1078 instruments
82 countries
7 continents

Algeria - 2	Denmark - 3	Mexico - 21	Slovenia - 2
Antarctica - 1	Egypt - 3	Mongolia - 10	South Africa - 8
Australia - 7	Ethiopia - 14	Mozambique - 2	Spain - 1
Austria - 3	France - 9	Namibia - 1	Sri Lanka - 1
Azerbaijan - 2	Gabon - 1	Netherlands - 5	Sweden - 3
Bangladesh - 1	Germany - 30	New Zealand - 7	Switzerland - 4
Bhutan - 1	Greece - 7	Nigeria - 57	Taiwan - 4
Bolivia - 1	Guyana - 1	Pakistan - 4	Thailand - 5
Bosnia-Herzegovina - 2	Hungary - 1	Peru - 10	Tunisia - 9
Brazil - 11	India - 33	Philippines - 3	Turkey - 2
British Virgin Islands - 1	Indonesia - 2	Poland - 2	Uganda - 5
Bulgaria - 2	Iran - 4	Portugal - 3	UK - 32
Burkina Faso - 1	Iraq - 1	Rep of Congo - 3	Uruguay - 9
Canada - 33	Ireland - 9	Romania - 4	US Virgin Islands - 2
Chile - 1	Italy - 42	Russia - 3	USA - 491
China - 38	Kenya - 23	Rwanda - 1	Uzbekistan - 2
Columbia - 9	Korea (South) - 2	S Africa - 4	Venezuela - 2
Croatia - 7	Lebanon - 11	Senegal - 1	Vietnam - 1
Cyprus - 1	Libya - 1	Serbia - 1	Zambia - 2
Czech Republic - 1	Malaysia - 19	Singapore - 3	
D Rep of Congo - 4	Malta - 1	Slovak Repub - 2	

<i>For official use only</i> Monitor assigned: _____ Site name: _____ Country: _____

SuperSID Space Weather Monitor Request Form

	<i>Your information here</i>		
Name of site/school (if an institution):			
Choose a site name: (3-6 characters) No Spaces			
Primary contact person:			
Email:			
Phone(s):			
Primary Address:	Name School or Business Street Street City Country	State/Province Postal Code	
Shipping address, if different:	Name School or Business Street Street City Country	State/Province Postal Code	
Shipping phone number:			
Latitude & longitude of site:	Latitude: _____ Longitude: _____		

I understand that neither Stanford nor the Society of Amateur Radio Astronomers is responsible for accidents or injuries related to monitor use. I will assure that a surge protector and other lightning protection devices are installed if necessary.

Signature: _____ **Date:** _____

I will need:

<i>What</i>	<i>Cost</i>	<i>How many?</i>
SuperSID distribution USB Power	\$48 (assembled)	
USB Sound card 96 kHz sample rate (or provide this yourself)	\$15 (optional)	
Antenna wire (120 meters) (or you can provide this yourself)	\$23 (optional) with connectors attached and tested	
RG 58 Coax Cable (9 meters) (or provide this yourself)	\$14 (optional) with connectors attached and tested	
Shipping	US \$12 Canada & Mexico \$40 all other \$60	
	TOTAL	\$

_____ I have included a \$_____ check (payable to SARA)

_____ I will make payment thru www.paypal.com to treasurer@radio-astronomy.org

or

_____ If you are a Minority-serving institution, in a Developing or economically deprived nation, and/or you are using the monitor with students for educational purposes, you may qualify for obtaining a monitor at reduced or no cost. Check here if you wish to apply for this designation. Then tell us how you want to use the SuperSID monitor. Include type of site, number of students involved, whether public or private school, grade levels, etc. and describe your program. The goal of the SuperSID project is to provide as many students with systems as possible. If you are able to pay for a system, even if you qualify for a free one, please do so and help support our goal.

For more details on the Space Weather Monitor project, see: <http://sid.stanford.edu>

To set up a SuperSID monitor you will need:

1. Access to power and an antenna location that is relatively free of electric interference (could be indoors or out)
2. A **PC**** with the following minimal specifications:
 - A sound card that can record (sample) up to 96 kHz, or a USB port to connect such a sound card (for North and South America)
 - All other countries can use AC97 sound card with 48 kHz record (sample) rate. Most computers made after 1997 will have AC97.
 - Windows 2000 or more recent operating system
 - 1 GHz Processor with 128 mb RAM
 - Ethernet connection & internet browser (desirable, but not required)
 - Standard keyboard, mouse, monitor, etc.
3. An inexpensive antenna that you build yourself. You'll need about 120 meters (400 feet) of **insulated** wire. Solid wire is easier to wind than stranded. Magnet wire will work but be more fragile. You can use anything from #18 to #26 size wire. The antenna frame can be made of wood, PVC pipe, or similar materials. We'll provide instructions. You can purchase the wire from us or obtain your own.
4. RG58 coax cable with a BNC connector at one end to run from the antenna to the SuperSID receiver. 9 meters is recommended, but the length will depend on where you place the antenna. You can purchase the coax from us or obtain your own.
5. Surge protector and other protection against a lightning strike

Return this form to: SuperSID@radio-astronomy.org

or mail to: SARA
Dennis Farr, SARA Treasurer
10760 Central Park Ave.
New Port Richey, FL 34655

Impedance Matching Issue with the CALLISTO Solar Radio Spectrometer

Christian Monstein & Whitham D. Reeve

One of the main components of a CALLISTO (Compound **A**stronomical **L**ow frequency **L**ow cost **S**pectrometer and **T**ransportable **O**bservatory [1]) is the commercially available Philips TV-tuner CD-1316, which has an antenna input impedance of $75\ \Omega$ according to the datasheet [2]. This impedance does not fit to the remaining components of a radio telescope like connectors, cables, low noise amplifier, and antenna, which usually are designed as $50\ \Omega$ components. Ideally, all components in an RF-system have the same wave impedance to avoid standing waves and minimize unwanted gain or loss in the receiver chain. Questions arose many times whether this mismatch is a serious issue or whether we can ignore it. The only way to get an answer is to measure the input reflection coefficient s_{11} [3] of the tuner with a vector network analyzer (VNA) as shown in figure 1.

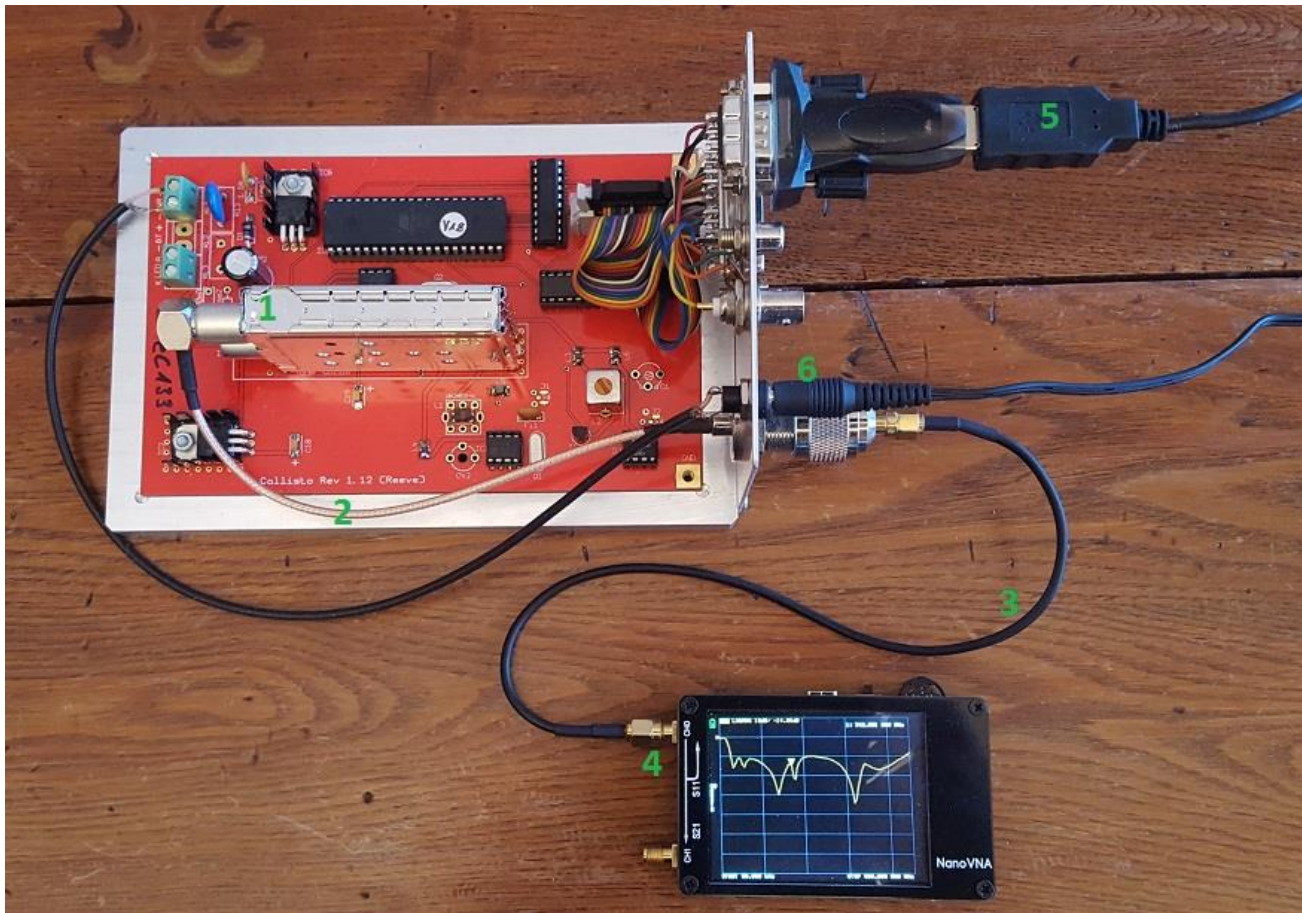

Fig. 1: Measurement setup with CALLISTO s/n eC133 printed circuit board mounted on a test frame. Key (green): 1 = Tuner antenna input $75\ \Omega$; 2 = SMA cable from tuner to antenna input $50\ \Omega$; 3 = Short SMA cable to connect NanoVNA $50\ \Omega$; 4 = s_{11} port of NanoVNA; 5 = Serial connection to the Windows 7 notebook for programming CALLISTO; 6 = 12 volts power cord. The current s_{11} measurement point on the VNA at 342 MHz indicates $-14.79\ \text{dB}$.

Fortunately, there are very cheap VNAs available on the market, e.g., the NanoVNA which can cover 50 KHz up to 900 MHz for less than 100\$ [4]. Measurement of s_{11} is not trivial because CALLISTO is not a single frequency

receiver, it is a frequency agile spectrometer, and each frequency shows a different input reflection coefficient s_{11} . Therefore, we need to measure s_{11} for many frequencies.

The measurement setup is shown in figure 1 and is composed of the NanoVNA, CALLISTO and a notebook PC. The notebook controls the CALLISTO by commanding the instrument via a terminal program such as PUTTY. While the NanoVNA measures a set of frequencies in the range 50 KHz – 900 MHz, the CALLISTO tuner is manually changed from one frequency to the next, in this case from 45 MHz up to 870 MHz in steps of 9 MHz. The frequency step size of 9 MHz was chosen because the NanoVNA can measure 100 points, giving a frequency resolution of exactly 9 MHz for the 900 MHz measurement range.

The selection of the CALLISTO frequency is through its serial interface. For example, 342 MHz is commanded as the text entry F0342<ENTER>. After setting the frequency, the cursor of the NanoVNA was scrolled to the same frequency and s_{11} was read out and entered into an ASCII text file. Once the full frequency range was covered, the text-file was fed into a Python script which read the data and produced a plot as shown in figure 2.

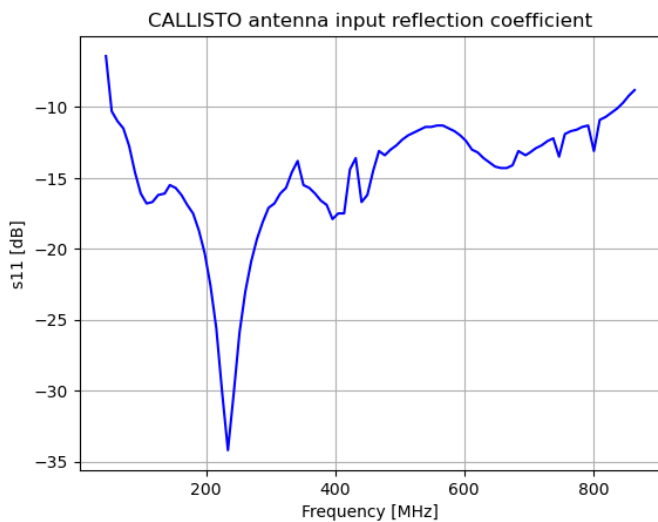

Fig. 2: Measurement results for CD1316LS/IV-3 tuner input reflection coefficient s_{11} between 45 MHz and 870 MHz in steps of 9 MHz. Values of s_{11} below -10 dB are acceptable in terms of mismatch.

We recognize that every individually programmed frequency appears with its own reflection coefficient and it varies by several dB. Neighboring frequencies (aside of the programmed one) sometime show a better s_{11} , sometimes worse. We can state that s_{11} is mostly below -12 dB between 50 MHz and 750 MHz. Only at the edges of the frequency range does s_{11} get worse, but it still is around -8 dB. In other words, most of the frequencies have a mismatch on the order of 6% which we can neglect.

Impedance matching in RF equipment is sometimes improved by inserting a 50:75 ohm impedance matching pad or a 50:75 ohm impedance matching transformer. However, a minimum loss impedance matching pad introduces at least 5.7 dB loss to the RF circuit so it would significantly reduce system gain and drastically increase receiver noise figure, both by at least 5.7 dB. An example of a minimum loss matching pad is the Mini-Circuits (MCL) SFQFM-5075. This device would help to improve the reflection coefficient, is cheap at less than 50\$ and shows good VSWR at the input as well as on the output (see data sheet [5]).

Alternatively, one could use a matching transformer, for example the MCL SFMP-5075 for less than 100\$. It introduces only 0.4 dB attenuation (see data sheet [6]). Another example, described more below, is the MCL

TC1.5-1X+ 1.5:1 transformer (see data sheet [7]). However, the CALLISTO tuner is not a perfect 75 ohms across its frequency band, as indicated by the s11 measurements above, so the transformation will not always be to a perfect 50 ohms. Thus, a potential disadvantage of the transformer would be a bad input/output VSWR in addition to a small amount of loss, which would degrade the noise figure.

In late 2013 we experimented with the TC1.5-1X+ transformer to determine how it would affect the CALLISTO's noise figure. The transformer was mounted in a special test fixture as seen in figure 3. Measurements were made with and without the transformer in the input circuit. The measurements show that, with the transformer, the CALLISTO noise figure is generally higher and is increasing with frequency, see figure 4. We concluded that, with respect to the noise figure, the added cost of the transformer does not make much sense.

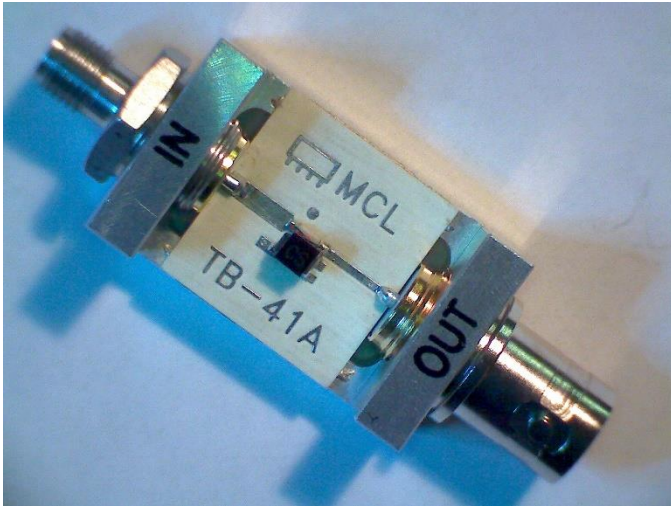

Fig. 3: Mini-Circuits TC1.5-1X+ impedance matching transformer in test fixture. The SMA-F connector on upper-left is the 50 ohm side and the BNC-F connector on the lower-right is the 75 ohm side. Two units were evaluated. The transformer itself is quite inexpensive at less than 3\$ but it is a surface mounted device that would have to be integrated into the CALLISTO at added cost.

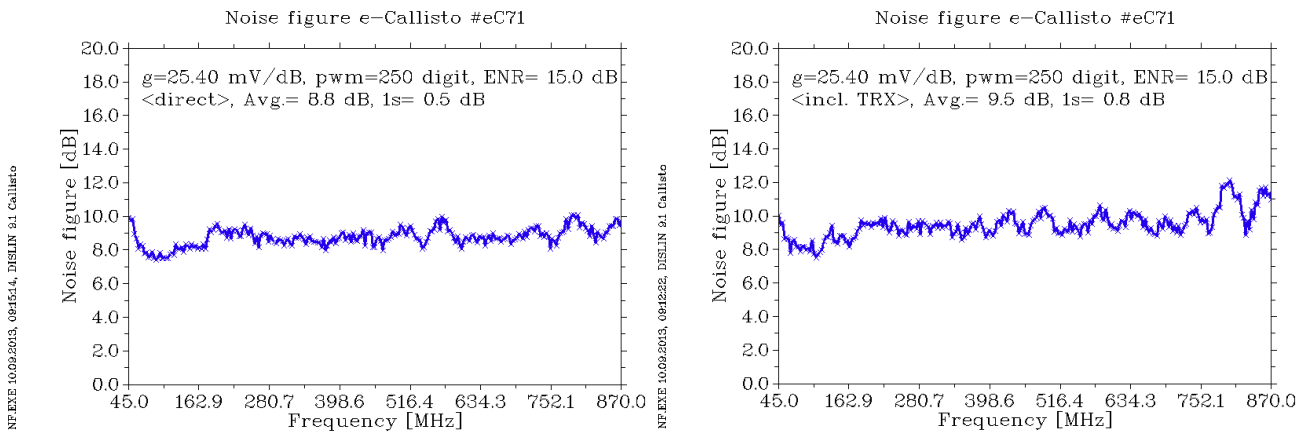

Fig. 4: Noise figure measurements with CALLISTO s/n EC71 without (on left marked <direct>) and with (on right marked <incl.>) the TC1.5-1X+ impedance matching transformer. The noise figure with the transformer is generally higher; the average noise figure increased by 0.7 dB and standard deviation of the individual noise figure measurements by 0.3 dB.

Links and references:

[1] CALLISTO: <http://e-callisto.org/>

[2] Tuner specifications Philips:

CD1316L/IV: http://e-callisto.org/Hardware/CD1300L_03.pdf

CD1316LS/IHP-3: http://e-callisto.org/Hardware/CD%28M%291300L_MK3%2005-09-01.pdf

[3] Reflection coefficient s11:

<https://resources.altium.com/p/s11-vs-return-loss-vs-reflection-coefficient-when-are-they-same>

[4] Nano VNA: <https://nanovna.com/>

[5] SFQFM-5075: <https://www.minicircuits.com/pdfs/SFQFM-5075+.pdf>

[6] SFMP-5075: <https://www.minicircuits.com/pdfs/SFMP-5075+.pdf>

[7] TC1.5-1X : <https://www.minicircuits.com/pdfs/TC1.5-1X+.pdf>

Authors :

Christian Monstein
Istituto Ricerche Solari Locarno (IRSOL)
Via Patocchi 57
6605 Locarno Monti
Switzerland
monstein@irsol.ch

Whitham D. Reeve
Anchorage, Alaska USA
whitreeve@gmail.com

Getting the Best out of the PRESTO Pulsar Search & Analysis Tools

Peter East

Abstract

PRESTO, the professional pulsar search and analysis software, is now the package of choice for amateurs detecting and studying pulsars. This article investigates validation issues for the weaker pulsar intercepts with an integrated/folded signal-to-noise ratios (SNR) below 10:1. These are not clearly highlighted by the efficient statistical processes in PRESTO that are essentially designed to detect new pulsars in a low radio interference (RFI) environment. Here, it is shown that for keen amateurs prepared to examine the signal-to-noise ratio of PRESTO processed data over a range of search parameters, improved recognition of pulsars with integrated SNRs much less than 10:1 is possible.

Introduction

Amateur detection of pulsars has gone well past the stage of achieving the impossible and now there is a tendency to professionalism by using the academically developed software packages such as PRESTO, TEMPO, SIGPROC etc.: in preference to producing homebrew software solutions. This is good as it brings some commonality, but there remain some constraints for amateurs with smaller antennas or even those with large antennas planning on detecting more pulsars just within the sensitivity limits of their more capable systems. The main difference between amateurs and professionals is that amateurs are unlikely to detect new pulsars and must content themselves with intercepting known pulsars with catalogued parameters. Indeed, the professional software packages have been developed specifically to search for new pulsar intercepts with unknown periods and parameters. Although this software is useful for amateurs, the results are not so well matched to the recognition of known pulsars at the lower amateur detected SNR levels as considered here, ranging below 10:1. This article examines the most used software package, PRESTO and investigates the advantage for amateurs of adding maximum signal-to-noise ratio (SNR) profiling to aid in validation of the weaker pulsar targets using a real example B0329 pulsar intercept SNR of 5.5:1.

PRESTO⁽¹⁾

From the PRESTO Home site, the introduction states:- "PRESTO is a large suite of pulsar search and analysis software developed by Scott Ransom mostly from scratch. It was primarily designed to efficiently search for binary millisecond pulsars from long observations of globular clusters (although it has since been used in several surveys with short integrations and to process a lot of X-ray data as well). It is written primarily in ANSI C, with many of the recent routines in Python. According to Steve Eikenberry, PRESTO stands for: **P**ulsa**R** **E**xploration and **S**earch **T**oolkit!"

The PRESTO tutorial⁽²⁾ describes the optimum search procedure with the outline reproduced in Appendix 1. Inspecting this list, it is clear that the important items for amateurs seeking to intercept known pulsars are just entries 2 and 12, RFI mitigation and folding. Pulsar identification or 'Profile significance tests' discussed by Lorimer and Kramer,⁽³⁾ describe two possible measures, profile SNR and the Chi-square statistic. The success of the PRESTO software in discovering new pulsars with unknown rotation periods has been due to the fast core recognition process using a modification of the Chi-square (χ^2) statistic that measures how well observed data conforms to a specific model. In this case, the model is the Gaussian or Normal noise distribution, typical of system and sky noise. The statistic provides an indication of the deviation from Gaussian when a significant pulsar pulse train is present as the processing searches a range of possible pulsar periods. An added problem is of course noise distribution deviation due to local radio frequency interference (RFI) - hence the importance of RFI mitigation. PRESTO has an excellent tool for finding and zapping RFI, *rfifind*; the use of this program tool is described in the tutorial⁽²⁾. This tool and the folding algorithm tool, *prepfold*, are of most interest to amateurs. The spectrum harmonic search tools are also of interest to amateurs with larger dish systems as these processes need stronger pulsar signals to overcome losses due to the second order detection process involved in spectrum monitoring. The χ^2 algorithm itself does not approach the discrimination of the pulsar folded signal-to-noise

ratio (SNR) value as discussed below; but since the pulsar pulse phase/position is unknown in a folding search until it has been located and impulsive interference is suppressed, calculating SNR on-the-fly is not nearly as fast or robust against interference.

The plan here is to use the PRESTO tools, first to recognize and nullify RFI so potentially optimizing the data for folding analysis. Then to use the *prepfold* tools with a range of parameters to collect folded data to reproduce the Dispersion Measure (DM), period (P) and period rate (P-dot) PRESTO search sub-plots, but now to apply SNR profiling.

First, follows a definition the of Chi-square and SNR functions and then a comparison of their discrimination properties.

Reduced Chi-Square (χ^2) and SNR Algorithms

The reduced χ^2 algorithm is used in PRESTO as a goodness-of-fit measure on folded data assuming the data is pure Gaussian/Normal distributed noise. With just noise, the measure gives a value close to unity but when a large pulsar pulse is present the numerical measure can be very large. It is not dependent upon the pulse phase so can be useful in period, P-dot and DM searches to track the pulsar amplitude profile offset.

The reduced χ^2 statistic is given by,

$$\chi_{red}^2 = \frac{1}{N-1} \sum_{p=0}^{p=N-1} \frac{(x_p - \bar{x})^2}{\sigma_p^2} \quad (1)$$

where, N is equal to the number of fold bins (is a measure of the 'degrees of freedom' = $N-1$).

\bar{x} , and σ_p are the mean and standard deviation estimates of the folded noise.

If x_p were solely folded samples of Gaussian noise, the right-hand part of Equation 1 is equates to one, but if a significant pulsar pulse (or skewed RFI) is present then the result will exceed unity. A good approximation for Equation 1, assuming a Gaussian-shaped pulse and a pulsar duty cycle = W/P (W = half height pulse width; P = pulsar period) is, $1 + SNR^2 \frac{W}{\sqrt{2}P}$, which illustrates the duty cycle dependency. i.e. improved discrimination with increased pulsar duty cycle.

The corresponding definition of signal-to-noise ratio (SNR) is,

$$SNR = \frac{x_{pm} - \bar{x}}{\sigma_p} \quad (2)$$

where, x_{pm} is the folded data maximum response.

Note: SNR in Equation 2 is a linear ratio (sometimes referred to as multiples of sigma). Conventionally SNR is defined as a power ratio. The output from square-law detection is a voltage, so to state SNR in decibels, its value should strictly be calculated from $20\log(SNR)$. To minimize confusion here, the linear ratio form is preferred.

The efficacy of either algorithm depends on obtaining good estimates of the folded data mean and standard deviation (sd or root mean square, $rms = \sigma_p$) values. Lorimer and Kramer³ suggest obtaining these values from a quiet section of the raw data and dividing the standard deviation estimate by the folding downsampling ratio (= the square root of the number of samples/number of folding bins). For less stable amateur systems there are other options. A two-stage method of obtaining a good accuracy SNR (SNR1 in Figure 1) involves first calculating the folded data mean and rms, setting thresholds at say, $\pm 3 \times rms$ level, inserting random noise within the $3 \times rms$ range of the thresholded regions, and finally recalculating mean and rms values for incorporating in equation 2. A faster simpler version, losing accuracy and discrimination at higher SNRs is to just use the first stage mean and rms estimates in Equation 2 (SNR2 in Figure 1). There are other options based on peak location and blanking with performances between the methods described.

Chi-square/SNR Discrimination Comparison.

Figure 1 models the χ^2 algorithm with two approximate SNR responses for the approximately 1% duty-cycle B0329 pulsar over a modest range. The χ^2 curve (red) shows good pulse amplitude tracking at high SNR levels, but for weak signals with SNRs below 20, the curve slope is much reduced offering much less amplitude discrimination. The curve is dependent upon pulsar pulse duty cycle so the χ^2 plot's curvature sharpens for pulsars with increased on/off ratio. A limiting value in the SNR2 approximation occurs as eventually it becomes a measure of the SNR of a noiseless, fixed duty cycle pulse model. However, SNR2 may still be a quick and simple discriminant for low SNR pulsar intercepts.

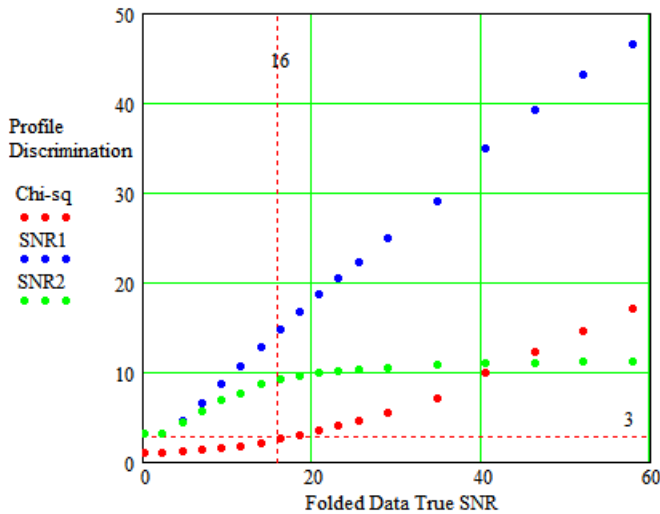

Figure 1. Comparison of Chi-square and SNR1 and SNR2 measures on a Folded Pulse Train

(Note: Reduced tracking of SNR1 due to the pulsar peak not lying centrally in a bin)

The plots are as defined, red: Chi-square, blue: best accuracy output SNR, green: approximate output SNR. The main conclusion drawn from Figure 1 is that due to the 'flatness', hence poor amplitude discrimination, of the χ^2 statistic at low SNR levels, it can only be expected to indicate good parameter search peaks for intrinsic SNRs greater than about 15:1 (certainly for 1% duty-cycle pulsars such as B0329). Below this level it seems that SNR is a better discriminant.

An interesting conclusion can be drawn from this graph. If there is sufficient amplitude discrimination using the χ^2 measure to validate Dispersion Measure search (DM), Period search and P-dot search graphs in the *prepfold* output plot for pulses with an SNR of 16:1, then by manually applying the SNR1 algorithm, apart from possible confusion with noise peaks, the corresponding validation level could now drop closer to 3:1 - the expected residual noise peak line. In practice, there are other validating characteristics (Appendix 2) which can be used to further support recognition success.

The process to obtain SNRs of the relevant search parameter data for this experiment (results described later) involved manually running the *prepfold* program on the RFI-mitigated data over the search parameter space. For each of the parameter best-profile data folds, a maximum SNR is recorded, and these values used to produce the duplicate search plots for comparison with the Figure 3 sub-plots. Both measures have similarities and can be seriously affected by RFI, hence the reason for attempts to first, mitigate it. Rolling SNR measurements are seriously affected by impulsive RFI and this is probably another reason why it is not the preferred measure in PRESTO.

The PRESTO *prepfold* Plot

A typical command line for the PRESTO RFI mitigating tool, *rfifind* is,

```
rfifind -o maskp2 -time 1 -chanfrac 1 -intfrac 1 -freqsig 18 -timesig 18 -zapchan 0:0,21:24 -zapints 0:0,10000:10000 datafile.fil
```

This generates an RFI masking file: *maskp2_rfifind.mask* which detects and blanks or in-fills adjustable time and frequency sections as well as in this case, blanking frequency channels 0 and 21 to 24 from the data file, *datafile.fil*. The data file is assumed in a standard *.fil* format.

The RFI masking file is then called up by the folding program *prepfold* with the full command line,

```
prepfold -mask maskp2_rfifind.mask -nsub 25 -n 714 -p 0.71447786 -topo -phs 0.5 -dm 27 -pd 0.0000000000 -nosearch -fine datafile.fil
```

In this example, the RF band is divided into 25 sub-bands, the data folded into 714 bins (~1ms/bin for convenience). The topocentric pulsar period (available from TEMPO) is inserted, as is the expected DM. The command specifies no period searching. Period search, DM search and P-dot search test values replace the corresponding -p, -DM, -pd values as required.

On completion, the program displays the following main plot and produces a number of associated data files. A typical PRESTO output plot after applying the *prepfold* tool on RFI cleaned data for a pulsar SNR of 15:1 is shown in Figure 2 (Double bi-quad antenna @ 422 MHz + Airspy R2 + 3 hours; A Dell'Immagine, July 2018). Top left is repeated the folded result of the best profile. Below this a time-waterfall plot on which faint trails indicate that the pulsar is present largely throughout the observation. To its right is the running reduced χ^2 integrated value. The final result is just under 5, indicating that the distribution is slightly more skewed than predicted for Normal noise but shows steady increase over the observation time.

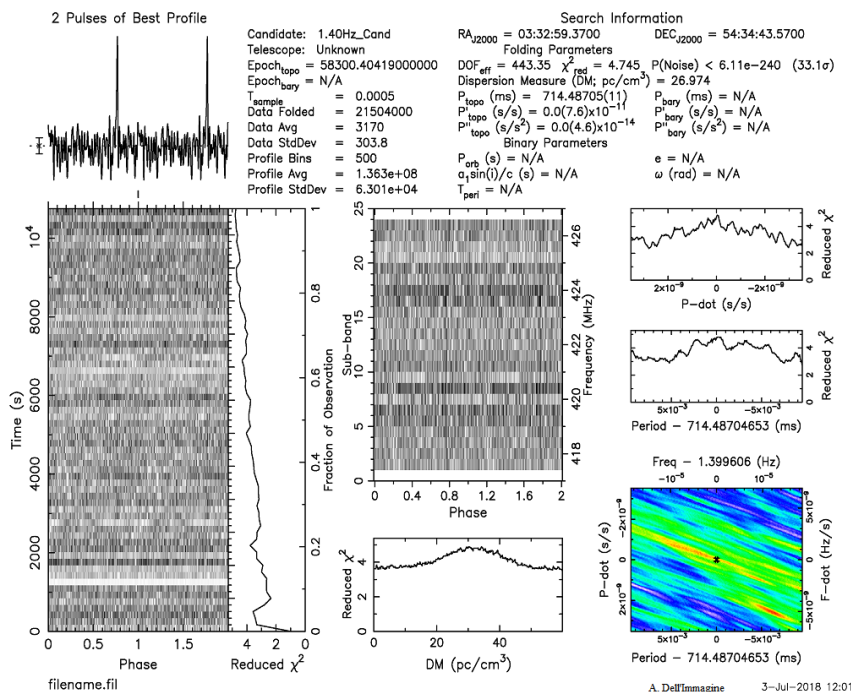

Figure 2. Typical PRESTO *prepfold* Data Plot with a folded signal SNR of 15:1

The waterfall shows that some RFI is still present. The center RF frequency graph again shows vestigial pulsar trails indicating the signal is indeed broad band.

The center-right graphs show the results of searching around the expected period and P-dot values. Both indicate a slight but 'noisy' (probably due to residual RFI) hump at zero error showing that the χ^2 discrimination response is just about adequate for B0329 at this site and 15:1 SNR. The bottom-right color plot combines the period and P-dot measures and largely indicates a central peak (red). Probably the most important plot is at bottom-center. This is a DM search and correctly shows a peak around DM = 27 as expected for the B0329+54 pulsar, but with relatively poor amplitude discrimination. The period and P-dot searches, apart from the small central peak, show no real off-zero structure. As a one-off data set, there is just about sufficient validation information here to confirm B0329 intercept but cleaner period and P-dot central peak plots expected from a continuous highly stable pulse train would certainly aid confidence.

Figure 3 shows a similar plot, but now with a pulsar SNR of 5.5:1 (Twin 2.5m, 17-element Yagi antenna @611MHz + Airspy R2 + 3 hours; PW East, August 2018). It is clearly evident that the reduced χ^2 statistic, value at around 3, cannot adequately confirm and validate that a pulsar is truly present from the DM, period and P-dot search plots although the 2-pulse best profile folded plot (top-left) looks promising and you might just fool yourself into seeing some very faint waterfall and frequency trails.

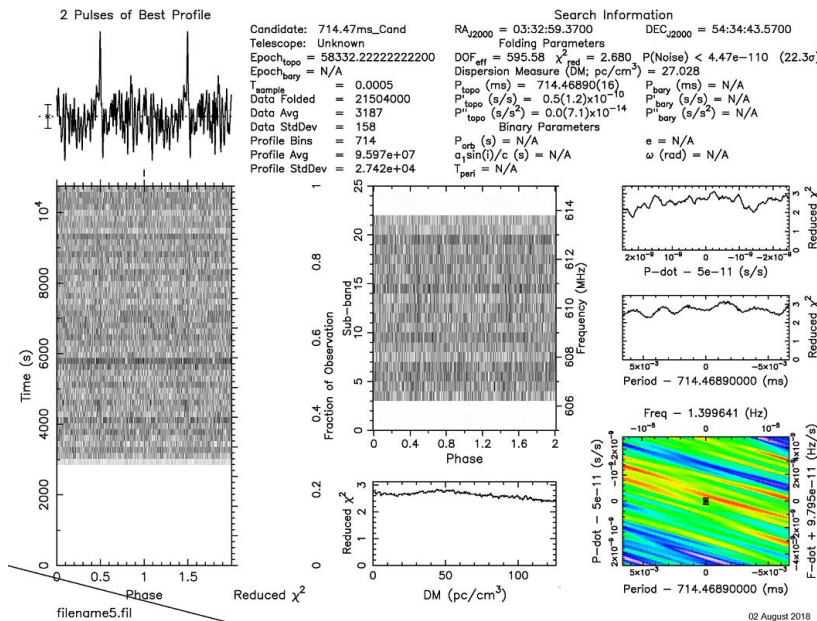

Figure 3. PRESTO *prepfold* Low SNR Data Plot with a folded signal SNR of 5.5:1

Fortunately, one of the files produced by *prepfold* contains the folded data bin values and is available for plotting separately, namely, *datafile_714.48ms_Cand.pfd.bestprof*. Giorgio and Andrea Dell'Immagine have produced a Python program that accesses this file to produce an SNR plot. With slight modifications it has been adapted to output the maximum SNR and its associated bin number. The next section describes a manual exercise to duplicate the SNR-based DM, period and P-dot *prepfold* sub-plots to assess pulsar recognition using SNR profiling to compare with the chi-square profiling.

Manual Search Results of 5.5:1 SNR Data

In each of the search plots reproduced in Figures 4, 5 and 6, the red points are the indicated maximum SNR values obtained from the *prepfold* best profile results using the SNR1 implementation on the Figure 3, *rfifind*-masked data.

The blue curves are those calculated assuming a continuous pulse train with frequency and pulse characteristics identical to the pulsar considered and folded using the standard algorithm. The three theoretical curves appear identical shapes, but in fact are slightly different, responding to the particular search parameter. The

background theory is similar to the scoring methods of Reference 4 but is explained in Reference 5; this is applied here and takes into account the blanked RFI space over the first third of this recording.

Figure 4 shows the SNR DM search results which now indicate a clear peak around the expected B0329 pulsar DM of 27, not evident in the χ^2 version reproduced to the right of Figure 4. It is interesting to note that the form and accuracy of Figure 4 SNR result more closely matches the χ^2 version of the 15:1 SNR plot in Figure 2 supporting the improved discrimination claim for SNR profiling.

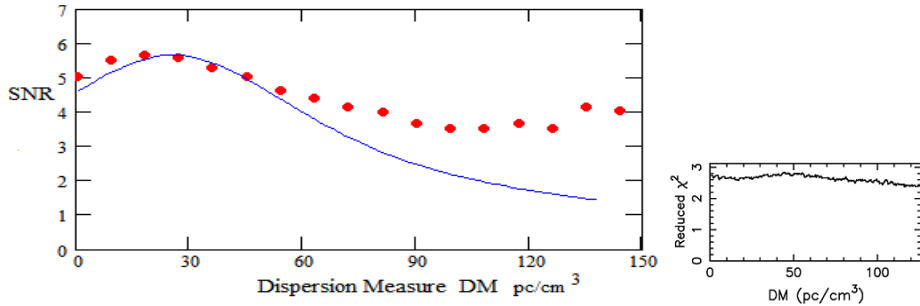

Figure 4. Dispersion Measure Search

This is sufficient to confirm that the source is broad band and dispersed as expected and the peak DM matches that of the expected source allowing for some distortion due to the underlying noise. The deviation from theory with increasing DM is anticipated as the source signal gets spread out in time, reducing its amplitude below that of the folded noise peaks.

Figure 5 shows the results for SNR period search with the period change ranging from -5 ppm to +5 ppm; the corresponding χ^2 version is on the right. There is a clear peak evident now in the SNR plot matching very closely to the expected value (TEMPO predicted) and the roll-off theory⁽⁵⁾ over the range -2 ppm to +2 ppm.

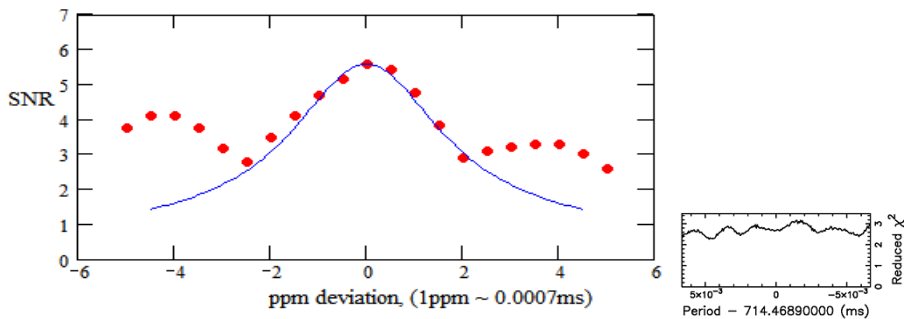

Figure 5. Period Search

Outside this range, random noise peaks appear to take over. The theory assumes a perfect pulse train matching the pulsar parameters implying that the pulsar pulse train is largely present throughout the data file. When the fold period is changed away from the correct value, for example, a true pulsar pulse position in the final period relative to the first period will have shifted. This has three effects after folding and they are, 1. the final summed pulse is broadened, 2. it is reduced in amplitude and 3. the pulse center will shift in relative time/bin. For a given data set these three effects are predictable for any substantially complete pulse train as described in Reference 5. Similar effects are predicted for DM and P-dot searches. Appendix 2 summarizes the part that matching these predicted responses has on validating the weaker SNRs.

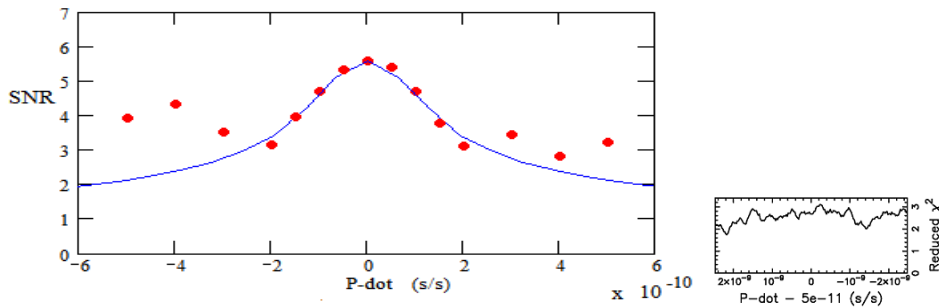

Figure 6. P-dot Search

The period-rate search, P-dot plot in Figure 6, again shows good conformity with theory over the range -2×10^{-10} s/s to 2×10^{-10} s/s, a peak at zero P-dot and the symmetry proving a high degree of frequency stability of the target ($\ll 1 \mu\text{s}$ over the observation period) as well as again demonstrating the presence of a continuous pulse train. Again for comparison, the χ^2 version on the same data is shown to the right.

Note that these searches report the maximum SNR value in the data fold. An alternative policy is to calculate⁽⁵⁾ the pulsar peak bin shift and report the data amplitude of this bin, adding confidence and possibly reducing the outlier values.

Spectrum Searches

A complementary method of pulsar searching is to Fourier transform (FT) the downsampled, RFI mitigated data file. With strong pulsar sources, these are visible as sets of predictable decaying harmonically related spectral lines. Figure 7 illustrates typical SNR results of the various methods with a model based on B0329 assuming an 8000 second data acquisition fully transformed in an 8 MB FT. The blue line represents the performance of maximum SNR with standard period folding.

Spectrum folding performance⁽⁶⁾ (red curves) does not equal this: the solid red curve is the result of folding all the significant pulsar harmonics using harmonic spacing rather than period spacing on the basic folding technique. Harmonic visibility cannot be expected in and below the 3:1 SNR region. The lowest red-dash curve corresponds to the SNR of the fundamental spectral line, requiring an integrated standard fold SNR of greater than 20:1 to ensure visibility.

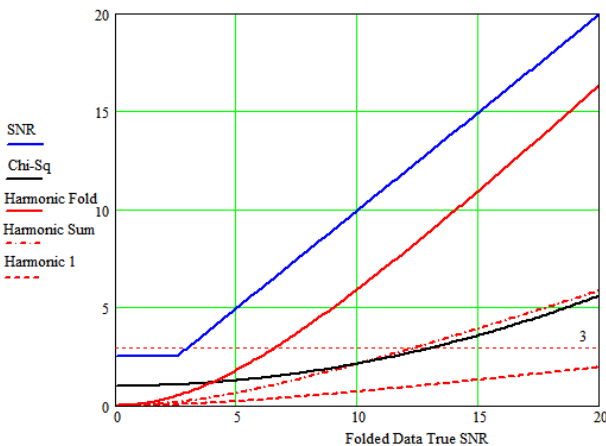

Figure 7. SNR Comparison with Chi-square and Spectrum Harmonic Folds

An improved harmonic visibility technique for narrow pulse pulsars is incoherent harmonic summing (centre red dash-dot curve). This involves stretching the frequency scale by factors 2, 3 etc.: and summing the spectra so enhancing duplicating/overlapping harmonic lines. Sensitivity improvement up to a factor of 3 is possible for a 1% duty-cycle pulsar⁽³⁾.

The curves are as labelled, spectrum harmonic folding offering the best sensitivity advantage, but falling significantly short of the standard folding SNR (blue). The harmonic sum technique appears in this example to give a similar detection performance to the Chi-square statistic (black) method.

Conclusions

As a one-off acquisition, with the added SNR profiling, there is now sufficient validation information recovered from this 5.5:1 SNR data to confidently confirm it as a B0329 intercept. Accurate tracking of the DM, period and P-dot search plots with those calculated for a stable pulse train of the same parameters as the pulsar provides the extra confidence.

What can be concluded from these results is that whilst PRESTO software tools are fast and great for finding new strong pulsars and mitigating RFI, they are not intended or so well matched to the needs of amateurs wanting to validate weaker known acquisitions with SNRs much below 10:1. However, comparing Figures 4 to 6 SNR plots to the corresponding PRESTO Chi-square sub-plots shows that with the addition of SNR profile analysis, considerably more detail and search discrimination is available. The close matching with the pulsar pulse train search theory is a measure over and above that of previous analysis software, but some automation of the manual process used here is to be desired.

A very large, correctly dispersed, broadband pulse of the right duration with a very stable period is a convincing pulsar. At lower SNRs however, it is important to increase validation confidence by closely tracking the defining pulsar parameters as listed in Appendix 2, coupled with a good understanding the differentiating characteristics of random noise and the various forms of RFI.

It is great bonus that professional radio astronomer's software is freely available to amateurs, but it is important for users to make themselves aware of its inner workings and what it was designed for, so that the results of the software tools can be properly interpreted.

With a little extra effort, as shown here, detection and recognition of pulsars in the SNR region well below 10:1, is definitely not out of bounds to amateurs with quite modest equipment.

Finally, from a detection sensitivity point of view no process or algorithm has been found that is as efficient as the standard period-folding algorithm when optimally band-limited.

Acknowledgements

The author acknowledges the ideas and support of Andrea and Giorgio Dell'Immagine for their guidance and use of the software⁽⁹⁾ they developed to acquire and process pulsar data.

References

1. PRESTO Home, <https://www.cv.nrao.edu/~sransom/presto/>
2. SM Ransom. Searching for Pulsars with PRESTO
https://www.cv.nrao.edu/~sransom/PRESTO_search_tutorial.pdf
3. D Lorimer, M Kramer., Handbook of Pulsar Astronomy. Cambridge University Press. 2005.
4. MJ Keith et al, 'Discovery of 28 pulsars using new techniques for sorting pulsar candidates' Mon.Not. R. Astron.Soc. 395, pp837-846(2009)
5. PW East. An Analytical Method of Recognizing Pulsars at Moderate SNR. Journal of the Society of Amateur Radio Astronomers. November-December 2018. p17.
6. PW East. Spectrum Techniques for Improving Low SNR Pulsar Detection. Journal of the Society of Amateur Radio Astronomers. March-April 2019.
7. PW East. A Correlation Method for Low SNR Pulsar Search and Recognition. Journal of the Society of Amateur Radio Astronomers. July-August 2019.
8. PW East. Getting the Best from the Pulsar Folding Algorithm. Submitted to the Journal of the Society of Amateur Radio Astronomers, September 2020.
9. G Dell'Immagine, A Dell'Immagine. Linux pulsar software for recording and analysis.
<https://github.com/gio54321/pulsar-distro-guide>
PW East January 2021

Appendix 1. Outline of a PRESTO Search - SM Ransom Tutorial²

- 1) Examine data format (readfile)
- 2) Search for RFI (rfifind)
- 3) Make a topocentric, DM=0 time series (prepdata and exploredat)
- 4) FFT the time series (realfft)
- 5) Identify “birdies” to zap in searches (explorefft and accelsearch)
- 6) Make zaplist (makezaplist.py)
- 7) Make De-dispersion plan (DDplan.py)
- 8) De-disperse (prepsubband)
- 9) Search the data for periodic signals (accelsearch)
- 10) Search the data for single pulses (single_pulse_search.py)
- 11) Sift through the candidates (ACCEL_sift.py)
- 12) Fold the best candidates (prepfold)
- 13) Start timing the new pulsar (prepfold and get_TOAs.py)

Appendix 2. Full Low SNR Validation Sequence

Validating Test Sequence	Evaluation
0. Radio Telescope Sensitivity	Basic check - SNR expected.
1. Correct period fold	TEMPO-matched. Calibrated system clock.
2. Pulse width.	Basic check.
3. Two/multiple-section fold correlation.	Matching pulse train present in data file sections.
4. Twin/multiple-period fold correlation.	Sequential pulses at expected period.
5. Multi-band correlation.	Broadband candidate - strong indicator.
6. Period search peak (Ref 5.) – profile, offset and pulse width	Continuous pulse train, accurate period at peak, check bin shift and pulse width increase.
7. P-dot search peak (Ref 5.) – profile, offset and pulse width	As 6 but also highlights high frequency stability and scintillation. Check with offset start period.
8. Dispersion search peak (Ref 5.) – profile, offset and pulse width	DM peak, bin shift and pulse increase, identifies as interstellar source - strong indicator.
9. Half-fold correlation (Ref 7.)	Identifies best candidates/ suppresses noise.
10. Multi-Bin fold plot (Ref 8.)	Differentiates pulse and noise.
11. Coherent spectrum sum (Ref 6.)	Harmonic and matched fold confirmation.

- Notes:**
1. Passing all Items 0 to 8 is essential, checks 9 to 11 add weight.
 2. Sporadic high level RFI (electrical machinery, impulsive signals etc: can be RF filtered or amplitude clamped/blanked at video. Once amplitude spikes are nulled, the chances of confusion is reduced but an equivalent RFI increase in base noise level can obscure a possible real candidate.
 3. Random noise peaks arise from folding and averaging all data noise and comprise components present in a major number of periods by chance. This means that some peaks are likely to persist in checks 3 and 4, but are unlikely to track in tests 5, 6, 7 and 8.
 4. At low SNRs, the true pulsar SNR value will be affected by the underlying noise so that in Tests 6,7 and 8 amplitude profiles will have some impressed variation which is increased for lower true SNRs. In this case it is better to track amplitudes at the expected bin number to discern profiles.
 5. Due to natural source scintillation and RFI uncertainties not all low SNR trials can be expected to be successful.



Peter East, pe@y1pwe.co.uk is retired from a career in radar and electronic warfare system design. He has authored a book on Microwave System Design Tools, is a member of the British Astronomical Association since the early '70s and joined SARA in 2013. He has had a lifelong interest in radio astronomy; presently active in amateur detection of pulsars using SDRs and researching low SNR pulsar recognition. He encourages free information exchange in the amateur community and is keen to widen interest in radio astronomy generally. He maintains an active RA website at <http://www.y1pwe.co.uk>

Sample of HF Meteor Trail Reflections Observed at Anchorage, Alaska USA

Whitham D. Reeve

This brief article shows some samples of meteor trail reflections (echoes) observed at the beginning and end of 2020; see figures 1 and 2, respectively. The reflections involve the time-frequency stations WWV or WWVH on 15 MHz and WWV on 25 MHz. Both stations are about 4000 km from Anchorage (figure 3). The samples show both short- and long-duration echoes. The short-duration echoes likely correspond to underdense meteor trails and the long-duration echoes to overdense meteor trails.

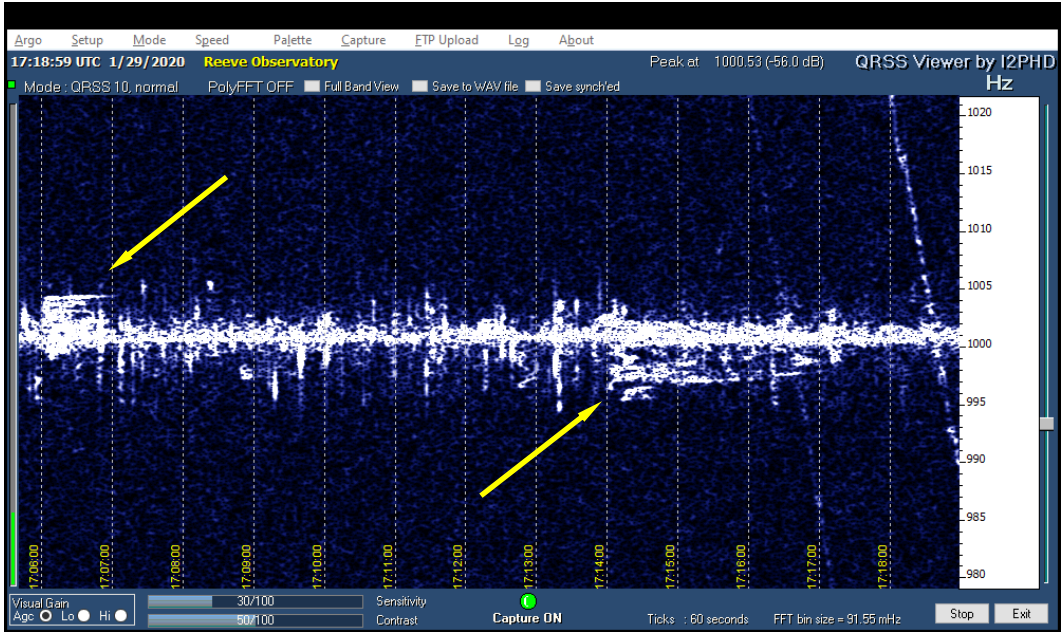

Figure 1 ~ 12-minute Argo record from 29 January 2020 ending at 1719 UTC.

Meteors probably are from the Quadrantids. The many blips and ticks are short-duration meteor trail reflections at 15 MHz. Two long-duration echoes are indicated by yellow arrows. The left-most echo lasted 1 min and the other 6 min. Both long-duration echoes are striated. A spurious signal slowly drifted through the narrow spectrum at 1718.

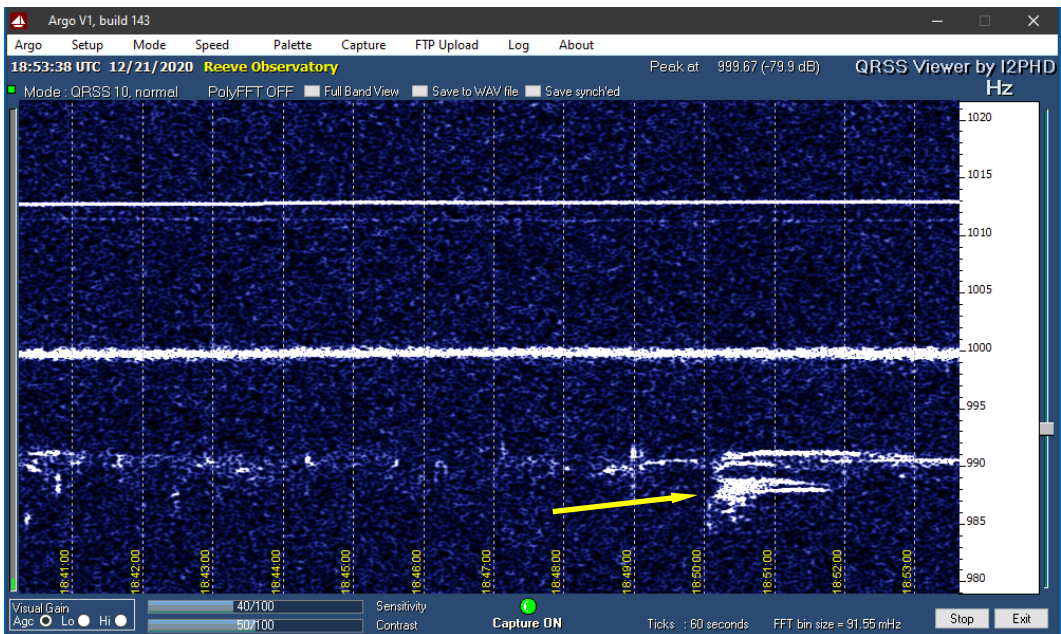

Figure 2 ~ 12-minute Argo record from 21 December 2020 ending at 1853 UTC.

The meteors probably are from the Geminids. The top trace is spurious, the middle trace is 15 MHz (either WWV or WWVH) and the bottom trace is WWV on 25 MHz. The yellow arrow points to a long-duration echo that has several striations. Some short-duration echoes also are visible.

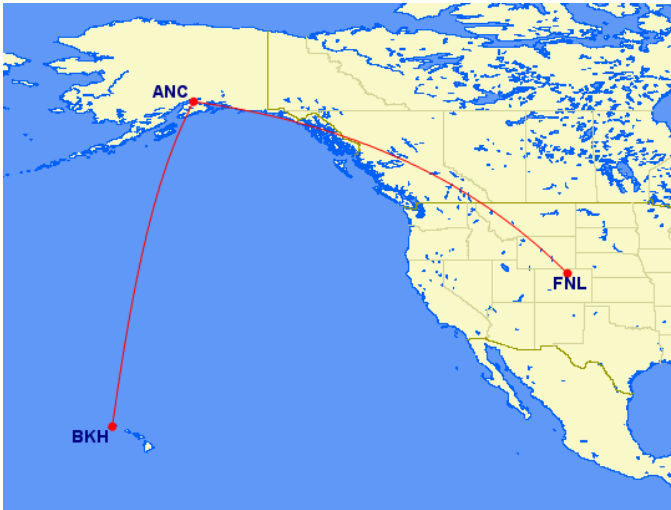

Figure 3 ~ Great circle paths shown in red between WWV near Fort Collins, Colorado (FNL) and Anchorage (ANC) and between WWVH near Kekaha on Kauai, Hawaii (BKH) and Anchorage. The WWVH path is 4414 km and almost entirely over water and encounters different propagation conditions than the WWV path, which is 3801 km and entirely over land. The paths are long enough to require multi-hop propagation. Anchorage is at the southern edge of the auroral oval, which introduces additional complicating factors in propagation toward Anchorage. Image from {GCMaP}.

The echoes at 15 MHz were observed with an Icom R-75 general coverage receiver tuned to 15 001 000 Hz and set to LSB mode, thus producing a 1000 Hz beat note that is processed by the Argo software. The echo at 25 MHz was observed with an Icom R-8600 general coverage receiver tuned to 25 000 990 Hz and set to LSB mode, thus producing a 990 Hz beat note that is processed by Argo. The AGC was turned off in both receivers. Both receivers were connected to the same antenna, an 8-element log periodic dipole array, through a multicoupler. A block diagram shows the general setup (figure 4).

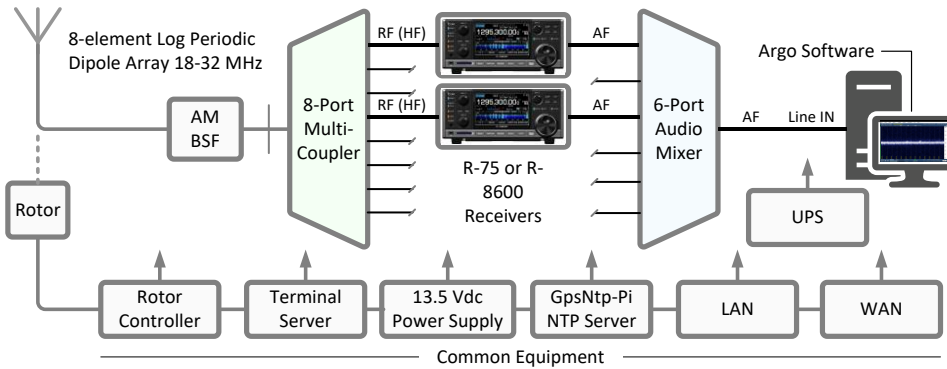

Figure 4 ~ Receiver and antenna system block diagram. PC timing is controlled by two GPS receiver-based network time servers. Common equipment includes infrastructure shared with other observatory equipment. The antenna usually was rotated to point at WWV on a true azimuth of 107°. Image ©2020 W. Reeve

The Argo software is setup for QRSS10 mode with a spectrum image length of 720 s (12 min), thus producing 43 800 images each year. Argo is adjusted to display a frequency span of 1000 ± 20 Hz, which encompasses the receiver settings mentioned above.

Near real-time Argo images may be found at the Reeve Meteor webpage at {Meteor}. The best time to observe meteor trail reflections at Anchorage is between about 1400 and 1900 UTC (0400 to 0900 local solar time).

Weblinks and references:

- {Meteor} http://www.reeve.com/Meteor/Meteor_simple.html
- {GCMaP} <http://www.gcmmap.com/mapui?P=FNL-anc-bkh>

Using a MAX 2870/71 Signal Source Generator as a Pulsar Simulator

Richard A. Russel

Abstract

A pulsar was simulated using a signal source generator that swept between 4 GHz and 6 GHz at a 10 MHz step size. This signal resulted in a simulated pulse period of 4.036 second and a pulse width (w50) of 85 millisecond. This approach had an added benefit of providing 2 GHz of signal which could be used by a remote observer to estimate the pulsar distance by measuring the dispersion measure of the high and low frequencies as they pass through the interstellar medium.

Components

The pulsar transmitter consists of a 5 GHz antenna and a signal source generator. (figures 1 and 2)



Figure 1: 5 GHz Antenna (amazon.com)



Figure 2: Signal Source Generator (amazon.com)

Assembly

The pulsar simulator was assembled using the MAX 2870/71 signal generator and the 5 GHz antenna. Note that the 5 GHz antenna is optional. (figure 3)

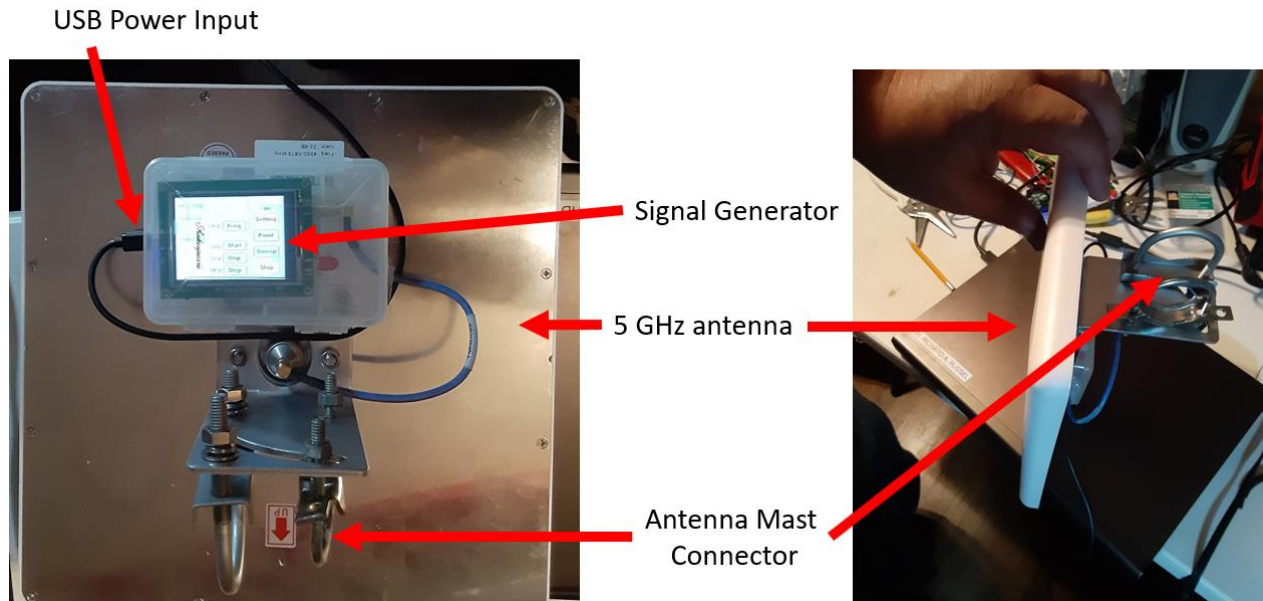

Figure 3: Pulsar Simulator Assembly

Signal Generator Setup

The signal generator was setup to sweep a signal from 4 GHz to 6 GHz using 10 MHz steps. This provided a simulated pulsar period of 4.036 second and a pulse width (W50) of 85 millisecond. The signal generator only required a USB power source. There is an ON/OFF switch on the lower right below the display. The signal generator setup is shown in figure 4. Start the pulsar simulator by touching the sweep button.

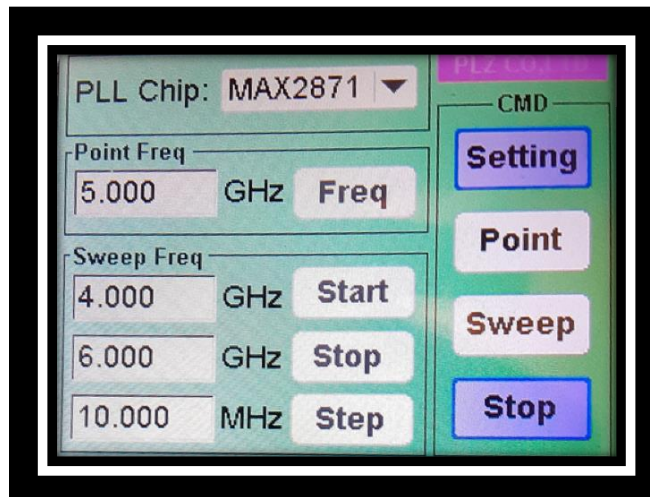

Figure 4: Signal Source Generator setup

Pulsar Simulator Output

The pulsar simulator was put next to a USRP B210 receiver that was tuned to 5 GHz. The signal was captured for 5 minutes and processed using PRESTO. The resultant output shows a characteristic pulsar. (figure 5)

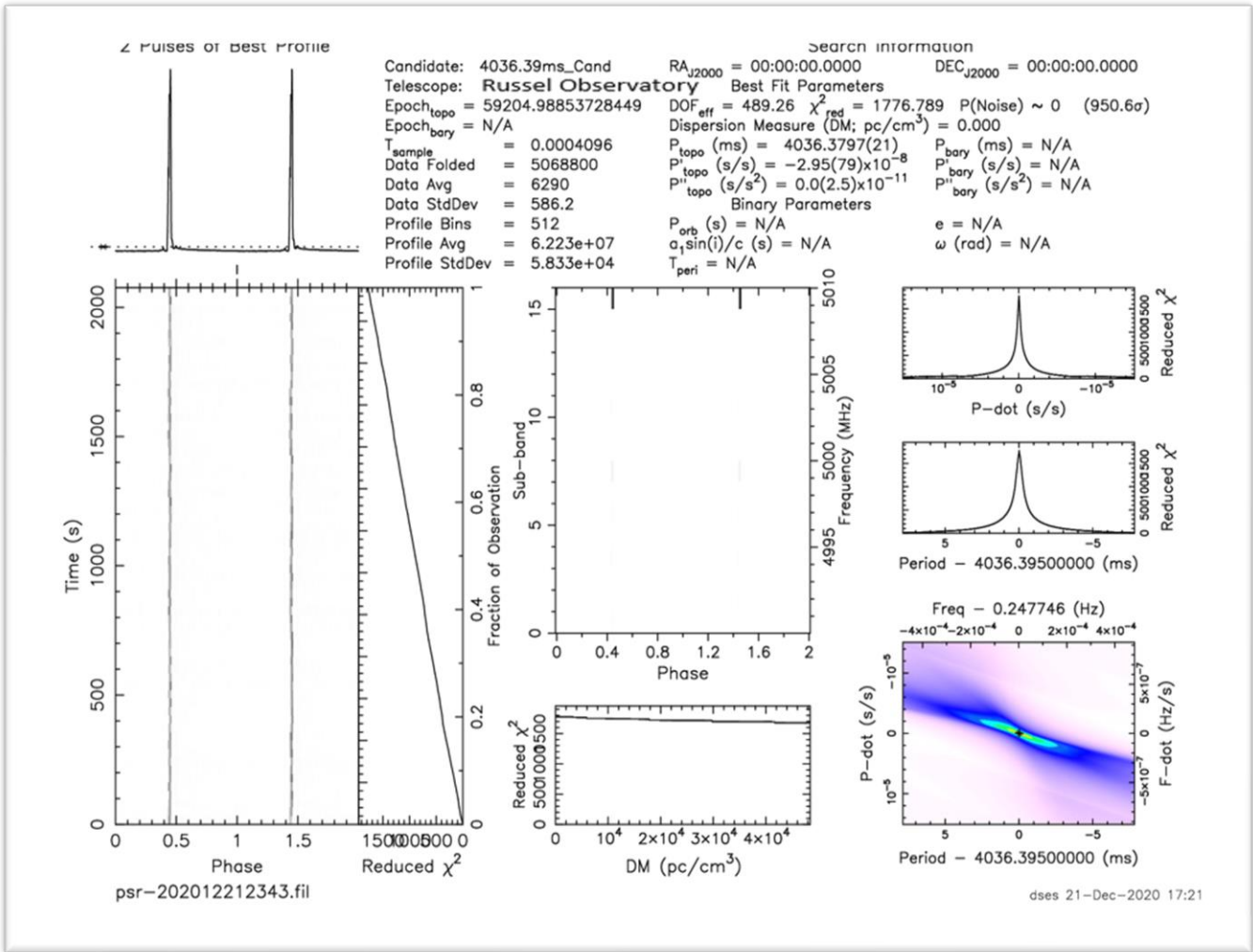

Figure 5: Pulsar Output

Analysis of the simulated pulsar data shows that the resultant pulse period is 4.036 second and the pulse width (W50) is 85 millisecond. (figure 6)

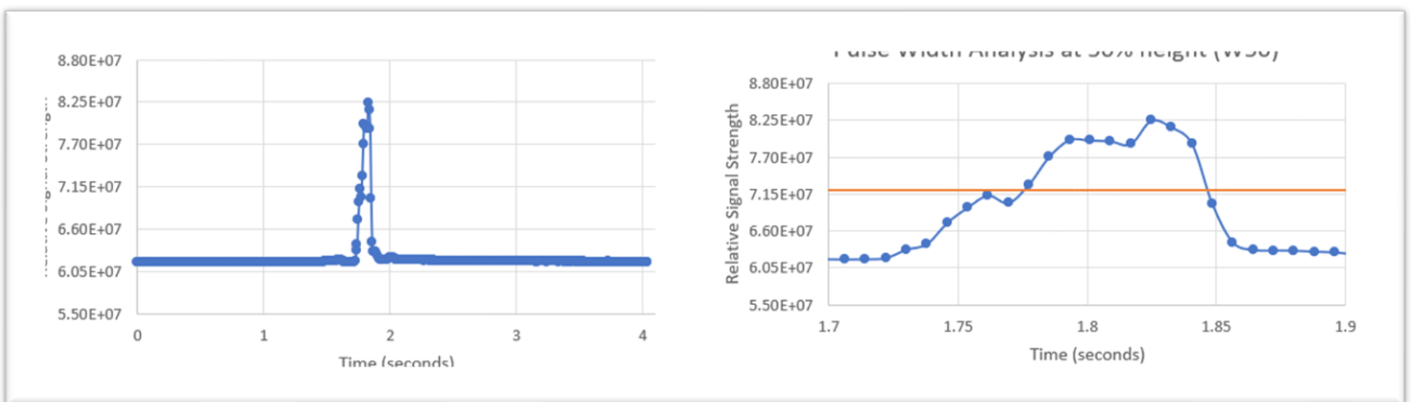

Figure 6: Pulsar Characteristics: period and pulse width analysis

Pulsar Simulator Settings Analysis

The signal source produced a pulsar signature when combined with a receiver that collected a signal at a certain center frequency and bandwidth. The pulsar simulation results of multiple combinations of frequency source settings and receiver settings are shown in figure 7.

MAX 2871 Settings		B210 Settings		Pulsar Results
Freq Range	Step Size	CTR Freq	BW	Period (seconds)
4-6 GHZ	10 MHZ	5GHZ	30 MHZ	4.016
4-6 GHZ	10 MHZ	5GHZ	20 MHZ	4.036
4-6 GHZ	10 MHZ	5GHZ	10 MHZ	4.040
4-6 GHZ	10 MHZ	5GHZ	5 MHZ	4.039
3-5 GHZ	10 MHZ	4GHZ	5 MHZ	4.039
3-5 GHZ	10 MHZ	4GHZ	10 MHZ	4.039
3-5 GHZ	10 MHZ	4GHZ	20 MHZ	4.036
3-5 GHZ	10 MHZ	4GHZ	30 MHZ	4.023
3-5 GHZ	5 MHZ	4GHZ	30 MHZ	8.009
3-5 GHZ	5 MHZ	4GHZ	20 MHZ	8.033
3-5 GHZ	5 MHZ	4GHZ	10 MHZ	8.033
3-5 GHZ	5 MHZ	4GHZ	5 MHZ	8.033
300 - 500 MHZ	1 MHZ	400 MHZ	5 MHZ	1.010
300 - 500 MHZ	1 MHZ	400 MHZ	10 MHZ	1.010
300 - 500 MHZ	1 MHZ	400 MHZ	20 MHZ	1.094
300 - 500 MHZ	1 MHZ	400 MHZ	30 MHZ	1.006

Figure 7: Pulsar Simulation Results Analysis

Summary

The MAX 2870/71 signal source was configured to simulate a pulsar. This allowed for receiver setup and pulsar processing training. The ease of use of the MAX 2870/71 provided a quick pulsar simulator that is an excellent tool for pulsar receive systems.

Richard A. Russel (AC0UB)



Dr. Rich Russel is the vice president for SARA and the current science lead for the Deep Space Exploration Society. He is a retired Northrop Grumman Senior Systems Engineer and served as the Chief Architect for the Satellite Control Network Contract (SCNC). In this capacity he was charged with planning the future architecture of the Air Force Satellite Control Network (AFSCN) and extending the vision to the Integrated Satellite Control Network (ISCN). Dr. Russel has been the lead architect and integrator for the Space-Based Blue Force Tracking project for U.S Space Command, the Center for Y2K Strategic Stability, and CUBEL Peterson. Dr. Russel also has led the SPAWAR Factory team in the deployment of the UHF

Follow-On Satellite system. He has a Doctorate in Computer Science, an Engineers Degree in Aeronautics and Astronautics, a Master’s in Astronautical Engineering, and a Bachelor’s in Electrical Engineering. He is also certified as a Navy Nuclear Engineer and he is a retired Navy nuclear fast attack submariner and Navy Space Systems Engineer.

Reference Frequency Distribution System

Whitham D. Reeve

1. Introduction

This article is related to my previous articles, **Using the SDRPlay SDR Receivers with an External Frequency Reference** {Reeve20} and **10 MHz Reference Distribution Amplifier** {Reeve17}, and describes a 6-port active Reference Frequency Distribution System (RFDS) that is usable with any single input frequency from below 5 MHz to above 100 MHz (figure 1). The RFDS can be equipped so that it is driven by an external precision frequency source or by an optional internal Mini-GPS Reference Clock module to provide an integrated precision reference frequency source with distribution (figure 2).



Figure 1 ~ Front view of the Reference Frequency Distribution System showing the six outputs and an optional GPS antenna resting on top. The rear panel, not seen here, holds the reference or GPS antenna input, an On-Off switch, power indicating LED and coaxial dc power jack. The enclosure dimensions are 1.77H x 4.27W x 6.30L in (45 x 108.5 x 160 mm) and weight is 1 lb (0.5 kg). Image ©2020 W. Reeve

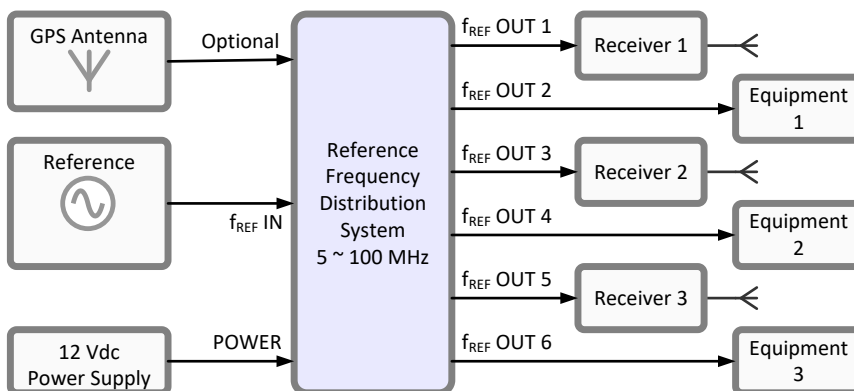

Figure 2 ~ Application of the Reference Frequency Distribution System. The external reference source or optional internal Mini-GPS Reference Clock with GPS antenna drives the distribution system. All outputs operate at the same frequency. Image ©2020 W. Reeve

The active distribution circuits used in the RFDS have no intentional filtering, which means that if the reference frequency source is distorted (includes spurious signals and harmonics), that distortion will be passed through to the outputs. The RFDS itself adds negligible distortion (measurements are given in section 4).

Most commercial and amateur reference frequency distribution systems operate only at 10 MHz and have a narrow bandwidth of a couple percent of the carrier frequency; thus, they cannot be used with many types of receivers and observatory equipment. For example, the SDRPlay receivers use 24 MHz and the DG8SAQ VNWA-series vector network analyzers use 36 MHz. The AirSpy, Icom R-8600 and RFSpace receivers use 10 MHz (the RFSpace SDR-14, which has no factory provisions for an external reference source, can be modified to use

66.66666 MHz). The RFDS operates on any single frequency, so if more than one reference frequency is required in an observatory, say 10 and 24 MHz, then a Reference Frequency Distribution System is required for each one.

2. Design

I was inspired by an article in the April 2020 issue of Silicon Chip magazine [SiliconChip] that described a *Frequency Reference Signal Distributor* meant for 10 MHz, but it used wideband components that I could see would easily support a range of lower and higher frequencies. The original design was based on the Maxim Integrated MX4450 integrated circuit operational amplifier with 210 MHz frequency range. I also used this amplifier in the RFDS but modified its application to more closely comply with the amplifier’s datasheet recommendations.

I also modified the internal power supply and added input overcurrent and overvoltage circuitry. The original design used a resistive voltage divider with a linear voltage regulator to produce 7 V operating voltage (V_{cc}) for the active circuits. My design operates directly at the voltage produced by an 8 V low dropout (LDO) linear voltage regulator. I designed the PCB to fit in common extruded aluminum enclosures and to also accommodate an optional Leo Bodnar Electronics Mini-GPS Reference Clock module as an internal reference source.

I used surface mounted devices (SMD) throughout except for the power and LED connector headers and voltage regulator ICs. The SMD resistors and capacitors are size 1206 (0.12 x 0.06 in), so are relatively easy to handle. The MAX4450 amplifiers are available in microminiature SC70 (SOT323) and larger SOT23 versions – I used the larger version, one per channel. The trace lengths to the amplifier inputs are short and direct but they are not identical; measurements shown in section 4 indicate there was no phase differential penalty for this configuration. The traces from the amplifier outputs and their associated circuits are identical. The PCB layout (figure 3) was prepared with Target 3001! printed circuit design software.

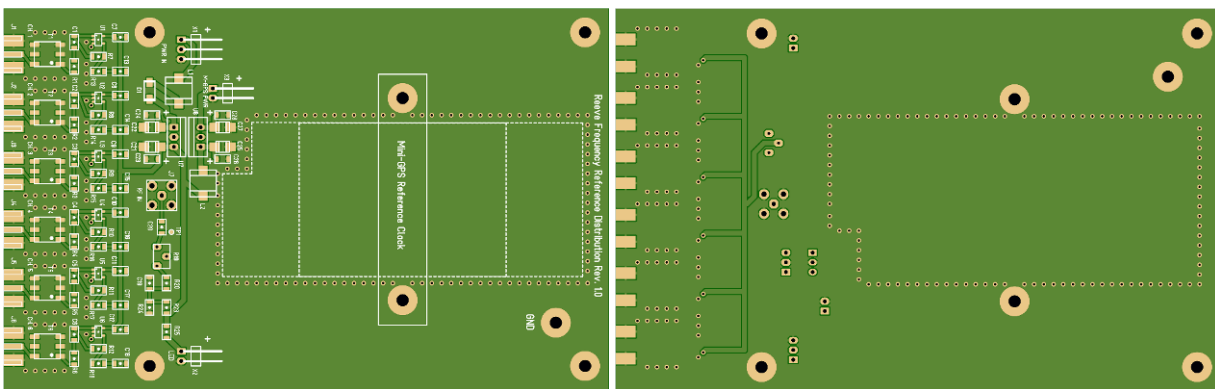

Figure 3 ~ Prototype printed circuit board top and bottom images produced from the PCB Gerber files and shown at 50% scale. The PCB is 100 x 160 mm and will fit many extruded aluminum enclosures, such as the Box Enclosures model B3-160. I equipped the PCB with four 3.2 mm diameter holes for mounting in an enclosure that does not have built-in PCB rails. The space dedicated to the Mini-GPS Reference Clock is seen in the silkscreened open area. In the prototype this unit was mounted with a brass strap fastened with screw fasteners. However, for production, I changed the PCB to use oblong holes so that small nylon tie wraps may be used in place of the metal strap and screws. The PCB may be used without the Mini-GPS Reference Clock and cut in half to fit an 80 mm long enclosure (such as the Box Enclosures B3-080). Image ©2020 W. Reeve

Operation is described in the following paragraphs and simplified block diagram (figure 4). The RFDS uses a 2-stage power supply with nominal 12 Vdc input. The input powering voltage to the RFDS can range from about 10 V minimum to 15 V maximum. Higher input voltages result in higher heat dissipation in the first-stage voltage regulator. The first stage supplies 8.0 V to the active circuits and power indicating LED and the second stage

supplies 5.0 V to the optional Mini-GPS Reference Clock. The 8 V LDO (low dropout) regulator output is connected to a resistance voltage divider that provides 4.0 V bias to each amplifier so that their inputs operate symmetrically between the power (Vcc) and ground rails. All inputs and outputs are dc isolated.

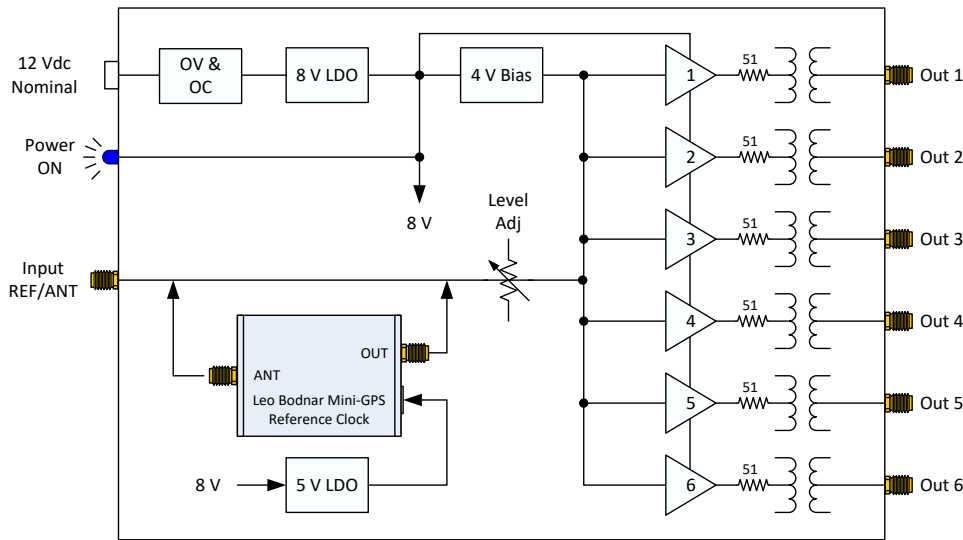

Figure 4 ~ Reference Frequency Distribution System simplified block diagram. The active circuits are powered by the 8 V LDO and the optional Mini-GPS Reference Clock is powered by the 5 V LDO. The Mini-GPS Reference Clock may be easily added or removed as needed. The amplifier outputs are connected to the coupling transformers through capacitors (not shown) for dc isolation and through 51 ohm resistors for impedance matching. Image ©2020 W. Reeve

The RF input from an external reference source or, optionally, from an internal Mini-GPS Reference Clock is capacitor coupled to a potentiometer for output level adjustment. The potentiometer slider is connected to the paralleled non-inverting inputs of six operational amplifiers. The amplifiers are configured for a voltage gain of 2. The overall power gain of the RFDS is adjustable from -7 to $+3$ dB (see section 4 for tests and measurements). Each amplifier output is capacitor coupled to a 1:1 wideband transformer through a 51 ohm resistor, which sets the output impedance of each channel to a nominal 50 ohms. Note that most devices that use a precision frequency source can accept a range of input voltages or powers so it should not be necessary to increase or decrease the level with an external amplifier or attenuator.

The Mini-GPS Reference Clock, if equipped, is hidden from access and view when the PCB is installed in an enclosure. This means that the reference frequency must be setup with the PCB removed from the enclosure so that the Mini-GPS Reference Clock can be connected to a PC with a USB cable. For setup, the Mini-GPS Reference Clock is disconnected from its power source on the PCB and temporarily connected to a Windows PC with a separate cable. At this point the Reference Clock is powered and controlled by the PC. After setup is completed, the Reference Clock is reconnected to the PCB. The LED on the Mini-GPS Reference Clock that indicates GNSS satellite fix is invisible when the PCB is installed in an enclosure, so a peephole was drilled in the enclosure end panel to observe the LED.

3. Construction

Construction is straight forward. The surface mounted devices are installed in the following order: Amplifiers, capacitors, resistors, and SMA-F bulkhead mount connectors. To ensure alignment of the SMA connectors on the PCB edge, I first cut holes in the end-panel and then mounted the connectors on it. I aligned the connectors on the PCB and checked that the assembly would line up properly when installed in the enclosure. I then soldered the connector pads. The through-hole components such as the voltage regulators and adjustment pot were installed last (figure 5).

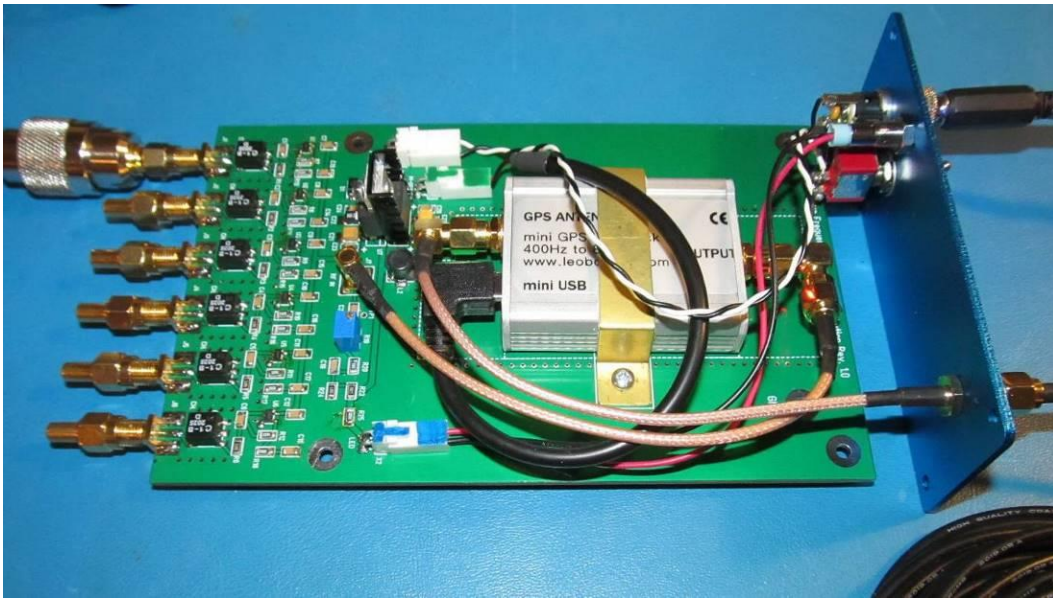

Figure 5 ~ Prototype of the Reference Frequency Distribution System with rear panel while under test. The SMA-F connectors for the six outputs are seen on the left edge of the PCB; channel 1 (upper-left) is connected to the spectrum analyzer for measurements and channels 2 – 6 have 50 ohm terminations. The output transformers are immediately to the right of the RF connectors, and the six identical amplifier circuits are to the right of the transformers. All components are grouped so that the PCB may be cut down and used in a shorter enclosure if the Mini-GPS Reference Clock is not equipped. It is shown here mounted with a metal strap (see text). The power and LED interfaces use friction lock connectors. The prototypes used an MCX-F socket on the PCB (seen here just to the left of the Mini-GPS Reference Clock antenna connection) for connecting the reference source input. This connector was replaced with an SMA-F connector in the production versions. Image ©2020 W. Reeve

I assembled the rear end panel with the power switch, filter capacitors, polarity guard diode, power indicating LED, locking-type coaxial power jack and SMA-F bulkhead mount connector for the external reference source input or GPS antenna. A cabling diagram clarifies the various connections to the PCB (figure 6). Drawings of the front and rear panels show the external controls and connections (figure 7).

The PCB assembly was installed in a Box Enclosures B3-160 extruded aluminum enclosure with PCB rails. White on clear labels were applied to the blue end-panels. Total parts cost including the PCB, enclosure and shipping but not including the Mini-GPS Reference Clock is approximately 170 USD.

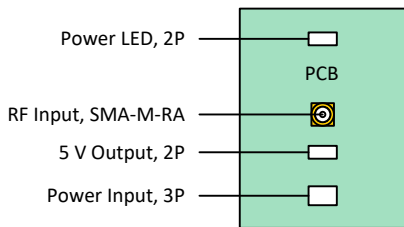

Figure 6 ~ PCB cabling diagram. The RF input uses a threaded RF connector and all other connectors use nylon, polarized, friction-lock wire housings. The connection labeled 5 V Output is for the optional Mini-GPS Reference Clock. The other wire connections go to the rear panel. The RF input connection also goes to the rear panel unless the Mini-GPS Reference Clock is equipped. The power input connector has 3 contact positions to differentiate it from the others; only 2 positions are used. Image ©2020 W. Reeve

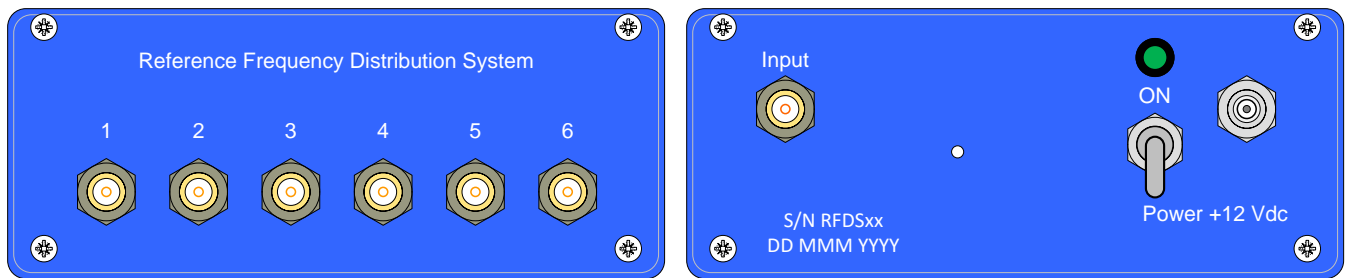

Figure 7 ~ RFDS front and rear end panels. Power is supplied through a locking-type 2.1 x 5.5 mm coaxial dc power jack and a toggle switch on the right side of the rear panel. The Input SMA-F connector on the left side of the rear panel is used for the reference source input or GPS antenna depending on if the Mini-GPS Reference Clock is equipped. A 2 mm diameter peep-hole is provided on the rear panel between the power switch and Input connector to allow viewing of the status LED on the Mini-GPS Reference Clock. Image ©2020 W. Reeve

4. Tests & Measurements

I used a variety of test equipment to make the RF measurements including a Siglent SSA3302X spectrum analyzer, Keysight N9917A Microwave Analyzer in Network Analyzer mode, a DG8SAQ VNWA-3SE vector network analyzer, Siglent SSG3032X RF signal generator and Siglent SDS2302X oscilloscope. The N9917A alone is capable of all the RF measurements, except the waveform, but I used this project as an opportunity to compare the results from other test sets. I used a Siglent SPD3303X power supply to power the RFDS for all measurements.

With 12.0 Vdc input voltage, the RFDS load current without the internal Mini-GPS Reference Clock and without an input signal is about 72 mA increasing to 81 mA with a 0 dBm input signal. With the Mini-GPS Reference Clock installed but before its receiver achieves a satellite fix, the total load is about 305 mA. When the receiver achieves a fix and is tracking satellites, the total load current increases to about 395 mA.

During the RF measurements of each channel, all unused outputs were terminated with 50 ohms. I also made a complete set of measurements with no terminations on the unused outputs and found no measurable differences. Nevertheless, good practice is to always terminate all unused RF ports.

I adjusted the prototype to provide nominal 0 dB power gain from the input connector to the output connectors at 10 MHz (level adjustments could be made at any desired frequency). These measurements were made with 10 dB attenuators on the signal generator output and spectrum analyzer input to ensure impedance matching (these attenuations are included in the instrument normalization). There are slight gain variations across the frequency range with some roll off between 50 and 100 MHz (figure 8). The measurements of phase difference between channels showed only a fraction of a degree up to 24 MHz and $< 2^\circ$ to 100 MHz; thus, the outputs can be considered *coherent*.

The RFDS outputs are well-matched to 50 ohms impedance with a return loss better than 14 dB from 5 to 50 MHz, equivalent to a VSWR better than 1.5:1. The best return loss is approximately 24 dB between 5 and 10 MHz. The input return loss is not nearly as good at about 7 dB, equivalent to 2.6:1 VSWR. The input return loss measurements were made with the input potentiometer set to provide 0 dB power gain.

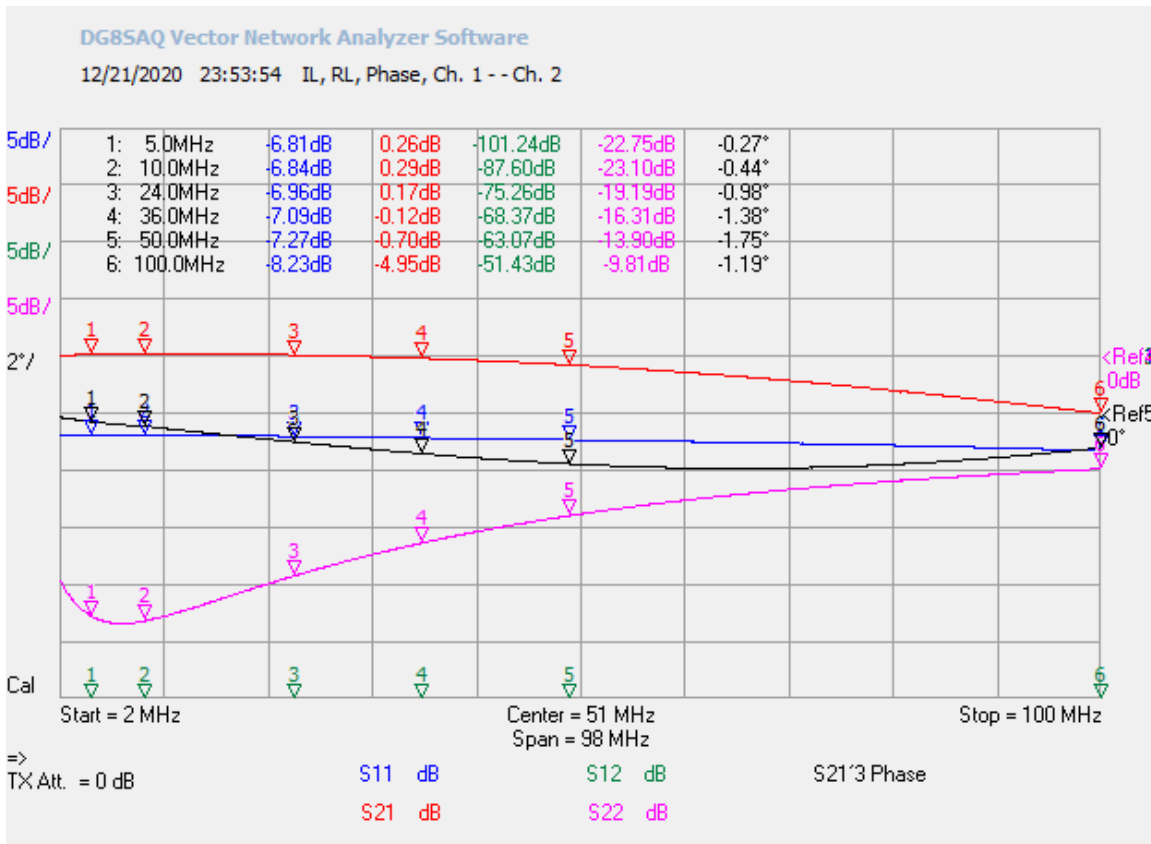

Figure 8 ~ The DG8SAQ VNWA-3SE vector network analyzer produced the measurements shown here for the input and channel 2 output. All channels showed the same results within a small fraction of a unit. The vertical scales are 5 dB/div except phase, which is 2° /div. The reference (0 dB or 0°) position for each trace is the 6th division from the bottom except for phase, which is the 5th division. The marker table at top shows the measurements at specific frequencies. S11 (blue trace) is the input reflection coefficient expressed in dB and equivalent to return loss. S21 (red trace) is the forward transmission coefficient from input to output expressed in dB and equivalent to transmission loss or gain. S12 is the reverse transmission coefficient in dB output to input (off scale but shown in the marker table), and S22 is the output reflection coefficient in dB. The trace marked S21'3 Phase (black trace) is the phase difference in degrees between the channel 1 and channel 2 outputs.

I would expect some variation in the input return loss with different settings of the potentiometer, but I did not measure it. The inferior matching on the input is the result of its simple design. An improved input design would use an impedance matching transformer along with a resistor divider network optimized for 50 ohms impedance. This would set the gain to a fixed, non-adjustable value. The system gain also can be altered by changing the resistor feedback network on the amplifiers. However, higher gain configurations have reduced bandwidth so the gain cannot be increased without penalty; the MAX4450 datasheet provides guidance.

An oscilloscope showed no obvious distortion in the RFDS output waveform (figure 9), so I examined the input and output signals with the spectrum analyzer. Distortion measurements were made by first examining the signal generator 10 MHz output (which would be the RFDS input) with the spectrum analyzer out to the 10th harmonic (100 MHz). The signal generator produced low-level spurious signals and harmonics at 15, 20 and 30 MHz (figure 10.a), amounting to a total harmonic distortion (THD) of approximately 0.69%. The signal generator was then reconnected to the RFDS and the RFDS output was viewed with another trace (figure 10.b). In this case, there were small changes in some of the existing harmonics and additional low-level harmonics appeared. However, the total harmonic distortion on the output, which includes input distortion products, was materially unchanged at 0.68%. Commercial distribution amplifiers that I have used in the past typically specify total harmonic distortion < 1%, so the RFDS performance is comparable. Note that, although I used marker values

from spectrum analyzer measurements to determine distortion products, I could have used the FFT math function in the oscilloscope to measure them.

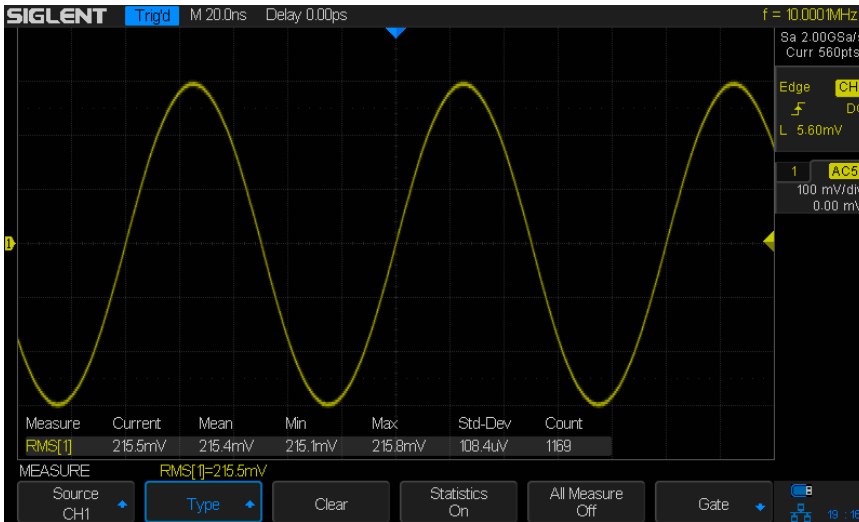

Figure 9 ~ The RFDS output displayed on the oscilloscope shows no obvious distortion. The scope is set to provide a 50 ohm termination. The vertical scale is 100 mV/div and the measured rms voltage, shown in the table below the trace, is 215 mV.

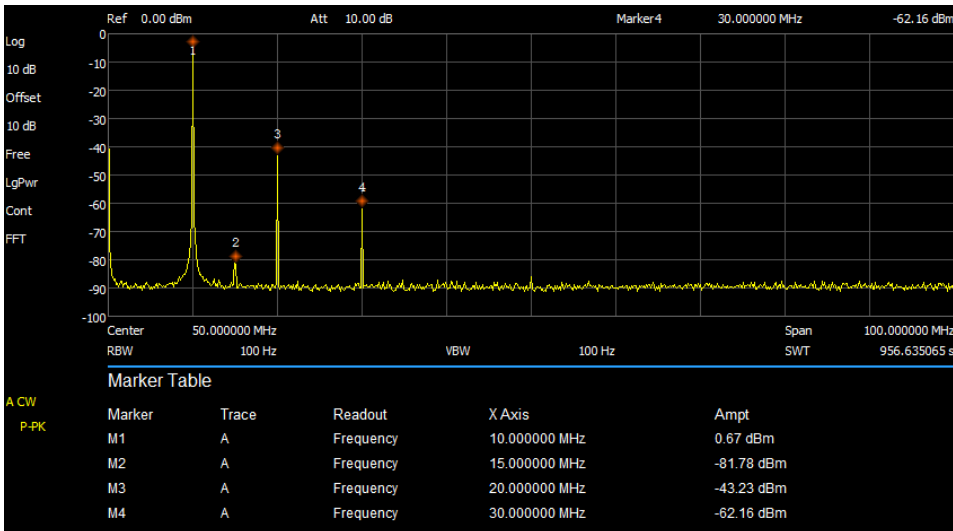

Figure 10.a ~ Signal generator (RFDS input) distortion measurements from 0 to 100 MHz. Weak 2nd and 3rd harmonics (markers 3 and 4) are present at -44 dBc and lower and a low level (-82 dBc) spurious signal at 15 MHz can be seen (marker 2).

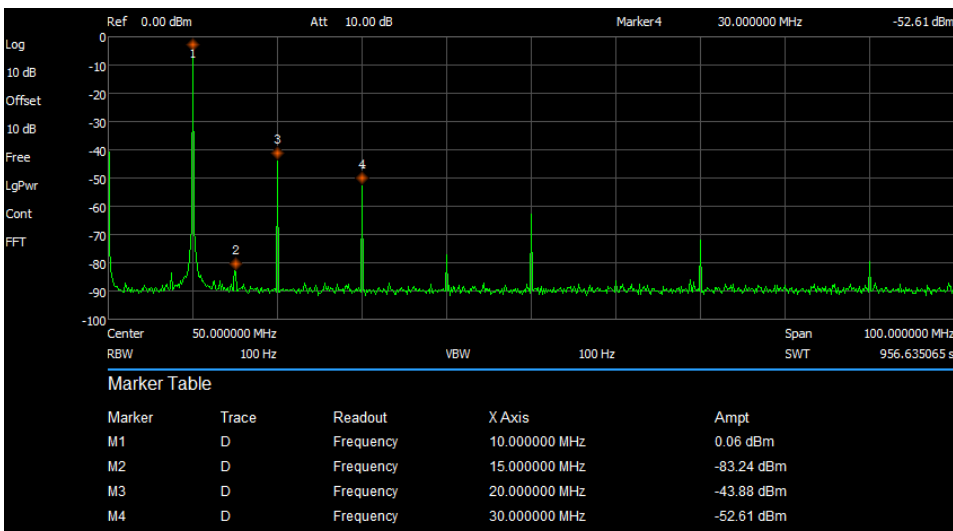

figure 10.b ~ RFDS output with the signal generator connected. The spurious signal at 15 MHz (marker 2) has decreased by 1.5 dB and the harmonic at 30 MHz (marker 4) has increased by about 10 dB. Additional harmonics at 40, 60, 70 and 90 MHz have appeared but their levels are below -60 dBc.

5. Conclusions

The Reference Frequency Distribution System provides six coherent outputs and operates on any single frequency between 5 and 100 MHz. Its parts cost is about 170 USD. An optional internal Mini-GPS Reference Clock may be equipped to provide a GNSS-based reference frequency for system operation, or an external precision frequency source may be used.

6. References & Weblinks

- {[Reeve17](#)} Reeve, W., 10 MHz Reference Distribution Amplifier, 2017, available at:
http://www.reeve.com/Documents/Articles%20Papers/Reeve_10MHzDist.pdf
- {[Reeve20](#)} Reeve, W., Using the SDRPlay SDR Receivers with an External Frequency Reference, 2020,
available at: http://www.reeve.com/Documents/Articles%20Papers/Reeve_SDRPlay-miniGPS.pdf
- [SiliconChip] Kosina, C., Frequency Reference Signal Distributor, Silicon Chip, April 2020
-



Author: Whitham Reeve obtained B.S. and M.S. degrees in Electrical Engineering at University of Alaska Fairbanks, USA. He worked as a professional engineer and engineering firm owner/operator in the airline and telecommunications industries for more than 40 years and now manufactures electronic equipment used in radio astronomy. He also is a part-time space weather advisor for the High-frequency Active Auroral Research Program (HAARP) and a member of the HAARP Advisory Committee. He has lived in Anchorage, Alaska his entire life. Email contact: whitreeve@gmail.com

Membership

New Members

Please welcome our new or returning SARA members who have joined since the last journal. If your name is missing or misspelled, please send an email to treas@radio-astronomy.org. We will make sure it appears correctly in the next Journal issue. As of December 15, 2020:

First name	Last name	City	State	Country	Call Sign
Brett	Dawson	Cooma	NSW	Australia	VK2CBD / AG7ZR
Juergen	Wenck	Neustadt in Holstein		Germany	DL2HAJ
Frank	Rawlins	Eatleigh	Hampshire	UK	
Andrew	Thomas	Tonbridge	Kent	UK	
Michael	Boss	Lacey	WA	USA	
Fred	Calvert	Cold Spring	KY	USA	
Kelcey	Davis	Imperial Beach	CA	USA	
Arabella	Duncan	Clinton	TN	USA	STUDENT
Michael	Duncan	Clinton	TN	USA	
Charles	Everding	Beavercreek	OH	USA	
Grant	Gimby	Mission Viejo	CA	USA	K6GMB
Scott	Kendall	Georgetown	TX	USA	
Dan	Layne	Larkspur	CO	USA	AD0CY
Robert	Luther	Burlington	VT	USA	
Gary	Oaks	Burlington	WI	USA	
Russell	Pinizzotto	Phippsburg	ME	USA	
Markus	Thomerson	Bowie	TX	USA	K5UFO

Membership dues are \$20.00 US per year and all dues expire in June. Student memberships are \$5.00 US per year. Memberships must be renewed on June of each year. Or pay once and never worry about missing your dues again with the SARA Life Membership. SARA Life Memberships are now offered for a one-time payment of twenty times the basic annual membership fee (currently \$400 US).

Journal Archives & Other CDs Promotion

The rich and diverse legacy of member contributed content is available in the SARA Journal Archives. Table of contents for journals is available online at <http://www.radio-astronomy.org/content-journal>

The entire set of The Journal of The Society of Amateur Radio Astronomers is available on CD. It goes from the beginning of 1981 to the end of 2017 (over 6000 pages of SARA history!) Or you can choose one of the following CD's or DVD:* (Prices are US dollars and include postage.)

† SARA Journals from 1981 through 2017

Prices, US dollars, including postage

Members

Each disk	\$15.00
Disk + 1-year membership extension	\$30.00

Non-members

Each disk	\$25.00
Disk + 1-year membership	\$30.00

Non-USA members

Each disk	\$20.00 (airmail)
Disk + 1-year members extension	\$35.00

*Already a member and want any or all these CD's or DVD's? Buy any one for \$15.00 or get any three for \$35.00.

SARA Store (<http://www.radio-astronomy.org/e-store>)

SARA offers the above CDs, DVDs, printed Proceedings and Proceedings on CD and other items at the SARA Store: <http://www.radio-astronomy.org/e-store>. Proceeds from sales go to support the student grant program. Members receive an additional 10% discount on orders over \$50 US. Payments can be made by sending payment by PayPal to treas@radio-astronomy.org or by mailing a check or money order to SARA, c/o Dennis Farr, 7237 Woodbrook Dr., Tampa, FL 33625.

SARA Online Discussion Group

SARA members participate in the online forum at <http://groups.google.com/group/sara-list>. This is an invaluable resource for any amateur radio astronomer.

SARA Conferences

SARA organizes multiple conferences each year. Participants give talks, share ideas, attend seminars, and get hands-on experience. For more information, visit <http://www.radio-astronomy.org/meetings>.

Facebook

Like SARA on Facebook <http://www.facebook.com/pages/Society-of-Amateur-Radio-Astronomers/128085007262843>

Twitter

Follow SARA on Twitter @RadioAstronomy1

What is Radio Astronomy?

This link is for a booklet explaining the basics of radio astronomy.
<http://www.radio-astronomy.org/pdf/sara-beginner-booklet.pdf>

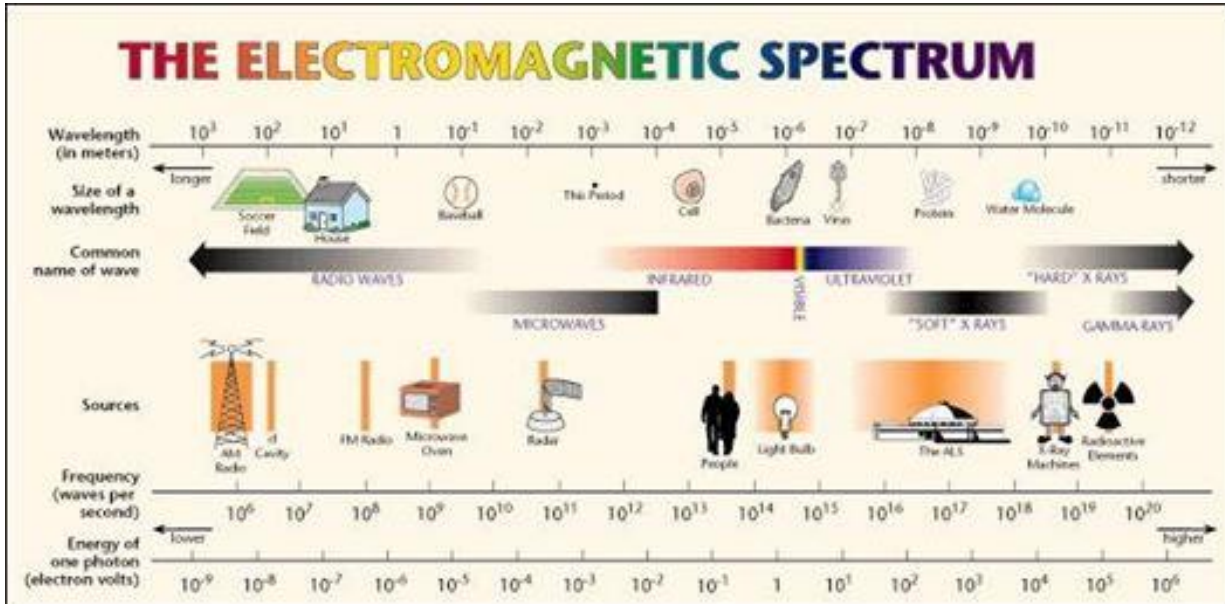

Administrative

Officers, directors, and additional SARA contacts

The Society of Amateur Radio Astronomers is an all-volunteer organization. The best way to reach people on this page is by email with SARA in the subject line SARA Officers.

President: Dennis Farr, WB4RJK, <http://www.radio-astronomy.org/contact/President> +1 248-425-6016

Vice President: Dr. Rich Russel, AC0UB <http://www.radio-astronomy.org/contact/Vicepresident>

Secretary: Bruce Randall, NT4RT, <http://www.radio-astronomy.org/contact/Secretary> +1 803-327-3325

Treasurer: Brian O'Rourke, K4UL, <http://www.radio-astronomy.org/contact/Treasurer>

Past President: Ken Redcap, tbd@radio-astronomy.org +1 319-591-1131

Founder Emeritus and Director: Jeffrey M. Lichtman, KI4GIY, jeff@radioastronomysupplies.com +1 954-554-3739

Board of Directors

Name	Term expires	Email
Wayne McCain, KS0S	2021	wayne.mccain@athens.edu
Charles Osborne, K4CSO	2021	k4cso@charter.net
Ed Harfmann	2022	edharfmann@comcast.net
Steve Tzikas	2022	Tzikas@alum.rpi.edu
Keith Payea, AG6CI	2022	kbpayea@bryantlabs.net
David Westman	2022	david.westman@engineeringretirees.org
Jon Wallace	2021	wallacefj@comcast.net
Dr. Wolfgang Herrmann	2021	messbetrieb@astropeiler.de

Other SARA Contacts

All Officers	http://www.radio-astronomy.org/contact-sara	
All Directors and Officers	http://www.radio-astronomy.org/contact/All-Directors-and-Officers	
Annual Meeting Coordinator	http://www.radio-astronomy.org/contact/Annual-Meeting	
All Radio Astronomy Editors	http://www.radio-astronomy.org/contact/Newsletter-Editor	
Radio Astronomy Editors	Bogdan Vacaliuc	bvacaliuc@gmail.com
	Richard A. Russel	drrichrussel@netscape.net
Contributing Editors	Steve Black	edit@radio-astronomy.org
	Whitham D. Reeve	whitreeve@gmail.com
	Mike Stewart	edit@radio-astronomy.org
Educational Outreach	http://www.radio-astronomy.org/contact/Educational-Outreach	
Grant Committee	grants@radio-astronomy.org	
Membership Chair (Tom Crowley)	http://www.radio-astronomy.org/contact/Membership-Chair	
Technical Queries (David Westman)	http://www.radio-astronomy.org/contact/Technical-Queries	
Webmaster	Ciprian (Chip) Sufitchi, N2YO	webmaster@radio-astronomy.org

Resources

Great Projects to Get Started in Radio Astronomy

Radio Observing Program

The Astronomical League (AL) is starting a radio astronomy observing program. If you observe one category, you get a Bronze certificate. Silver pin is two categories with one being personally built. Gold pin level is at least four categories. (Silver and Gold level require AL membership which many clubs have membership. For the bronze level, you need not be a member of AL.)

Categories include

- 1) SID
- 2) Sun (aka IBT)
- 3) Jupiter (aka Radio Jove)
- 4) Meteor back-scatter
- 5) Galactic radio sources

This program is a collaboration between NRAO and AL. Steve Boerner is the Lead Coordinator and a SARA member.

For more information:

Steve Boerner

2017 Lake Clay Drive

Chesterfield, MO 63017

Email: sboerner@charter.net

Phone: 636-537-2495

<http://www.astroleague.org/programs/radio-astronomy-observing-program>

Radio Jove



The Radio Jove Project monitors the storms of Jupiter, solar activity and the galactic background. The radio telescope can be purchased as a kit or you can order it assembled. They have a terrific user group you can join. <http://radiojove.gsfc.nasa.gov/>

INSPIRE Program



The INSPIRE program uses build-it-yourself radio telescope kits to measure and record VLF emissions such as tweeks, whistlers, sferics, and chorus along with man-made emissions. This is a very portable unit that can be easily transported to remote sites for observations. <http://theinspireproject.org/default.asp?contentID=27>

SARA/Stanford SuperSID



Stanford Solar Center and the Society of Amateur Radio Astronomers have teamed up to produce and distribute the SuperSID (Sudden Ionospheric Disturbance) monitor. The monitor utilizes a simple pre-amp to magnify the VLF radio signals which are then fed into a high definition sound card. This design allows the user to monitor and record multiple frequencies simultaneously. The unit uses a compact 1-meter loop antenna that can be used indoors or outside. This is an ideal project for the radio astronomer that has limited space. To request a unit, send an e-mail to supersid@radio-astronomy.org

Online Resources

British Astronomical Association – Radio Astronomy Group
<http://www.britastro.org/baa/>

CALLISTO Receiver & e-CALLISTO
<http://www.reeve.com/Solar/e-CALLISTO/e-callisto.htm>

CALLISTO data archive: www.e-callisto.org

Deep Space Exploration Society
<http://DSES.science>

European Radio Astronomy Club
<http://www.eracnet.org>

GNU Radio
<http://www.gnu.org/licenses/gpl.html>

Inspire Project
<http://theinspireproject.org>

NASA Radio JOVE Project
<http://radiojove.gsfc.nasa.gov>
Archive:
<http://radiojove.org/archive.html>

National Radio Astronomy Observatory
<http://www.nrao.edu>

NRAO Essential Radio Astronomy Course
<http://www.cv.nrao.edu/course/astr534/ERA.shtml>

Pisgah Astronomical Research Institute
<http://www.pari.edu>

SARA Twitter feed
<https://twitter.com/RadioAstronomy1>

SARA Web Site
<http://radio-astronomy.org>

Forum and Discussion Group
<http://groups.google.com/group/sara-list>

AJ4CO Observation of Jovian decametric emission
<http://www.radiojove.org/SUG/Observation%20Reports/AJ4CO/>

Radio Astronomy Supplies
<http://www.radioastronomysupplies.com>

Radio Sky Publishing
<http://radiosky.com>

RF Associates
Richard Flagg, rf@hawaii.rr.com
1721-1 Young Street, Honolulu, HI 96826
RFSpace, Inc.
<http://www.rfspace.com>

Shirleys Bay Radio Astronomy Consortium
marcus@propulsionpolymers.com

Simple Aurora Monitor Magnetometer
<http://www.reeve.com/SAMDescription.htm>

SETI League
<http://www.setileague.org>

Stanford Solar Center
<http://solar-center.stanford.edu/SID/>

UK Radio Astronomy Association
<http://www.ukraa.com/>

SARA Facebook page
<https://www.facebook.com/pages/Society-of-Amateur-Radio-Astronomers/128085007262843>

Radio Jove Spectrograph Users Group

<http://www.radiojove.org/SUG/>

Radio Astronomy calculators

<http://www.typnet.net/AJ4CO/Calculators/Calculators.htm>

Graphs, plots, equations, miscellaneous cheat sheets

<http://www.typnet.net/AJ4CO/index.htm>

Introduction to Amateur Radio Astronomy (presentation)

[http://www.typnet.net/AJ4CO/Publications/Intro%20to%20Amateur%20Radio%20Astronomy,%20Typinski%20\(AAC,%202016\)%20v2.pdf](http://www.typnet.net/AJ4CO/Publications/Intro%20to%20Amateur%20Radio%20Astronomy,%20Typinski%20(AAC,%202016)%20v2.pdf)

Pulsar Sounds: Audio recordings made by professional observatories

http://www.typnet.net/AJ4CO/Pulsar_Sounds/

For Sale, Trade and Wanted



SARA Polo Shirts

New SARA shirts have arrived.

We now have a good selection of X, XX, and XXX shirts available in all colors including white!

Shirts are \$20 at the conference and \$25 shipped.

Contact the treasurer at treas@radio-astronomy.org for availability and shipping.

SARA Ads

There is no charge to place an ad in Radio Astronomy; but you must be a current SARA member. Ads must be pertinent to radio astronomy and are subject to the editor's approval and alteration for brevity. Please send your "For Sale," "Trade," or "Wanted" ads to edit@radio-astronomy.org. Please include email and/or telephone contact information. Please keep your ad text to a reasonable length. Ads run for one bimonthly issue unless you request otherwise.

Send request to SARA by email to supersid@radio-astronomy.org. For more information: <http://www.radio-astronomy.org/pdf/sid-brochure.pdf>.

Description, items for sale by SARA	Price (US\$)
SuperSID VLF receiver (assembled)	\$48.00
USB soundcard, 96 kHz sample rate	\$15.00
Antenna wire 24 AWG (120 m)	\$23.00
Coaxial cable, Belden RG58U (9 m)	\$14.00
Shipping (United States)	\$10.00
Shipping (Canada, Mexico)	\$25.00
Shipping (all other)	\$40.00

Typinski Radio Astronomy, Inc., info@typinski.com

Antenna systems and feed line components for HF radio astronomy

Jeff Kruth, WA3ZKR, kmec@aol.com

RF components from HF to MMW, various types including mixers, RF switches, amplifiers, oscillators, coaxial components, waveguide components, etc. I have a very large collection of stuff and the facilities to test and provide data. Please email with your needs and I will see if I have something for you. Have fun!

Stuart and Lorraine Rumley, sales@valontechnology.com

The Valon Technology 2100 Downconverter, when combined with our 5009 frequency synthesizer module, provides a high-performance, compact receiver downconverter system. Applications include hydrogen line studies at 1420MHz and radio astronomy in the protected 30MHz segment of the 21 cm band. For more information visit <http://www.valontechnology.com/2100downconverter.html> or send an email.

Radio2Space, filippo.bradaschia@primalucelab.com

SPIDER radio telescopes and turn-key-systems designed specifically for education.

<https://www.radio2space.com>

We developed our SPIDER radio telescopes as turn-key-system just to avoid the problem you perfectly highlighted in your website: "Purchasing a radio telescope isn't like buying an optical telescope. They are harder to find, and usually require assembly and software troubleshooting. In some cases, a radio telescope must be built from components." Our SPIDER radio telescopes are not designed for amateurs that prefer to build a radio telescope but to schools, universities, museums, and other science institutes that needs for a complete and ready-to-use system, just like the optical telescopes they can normally buy!

Radio Astronomy Supplies

<http://www.radioastronomysupplies.com>

jeff@radioastronomysupplies.com

Research and Educational Radio Telescopes and all associated equipment since 1994